

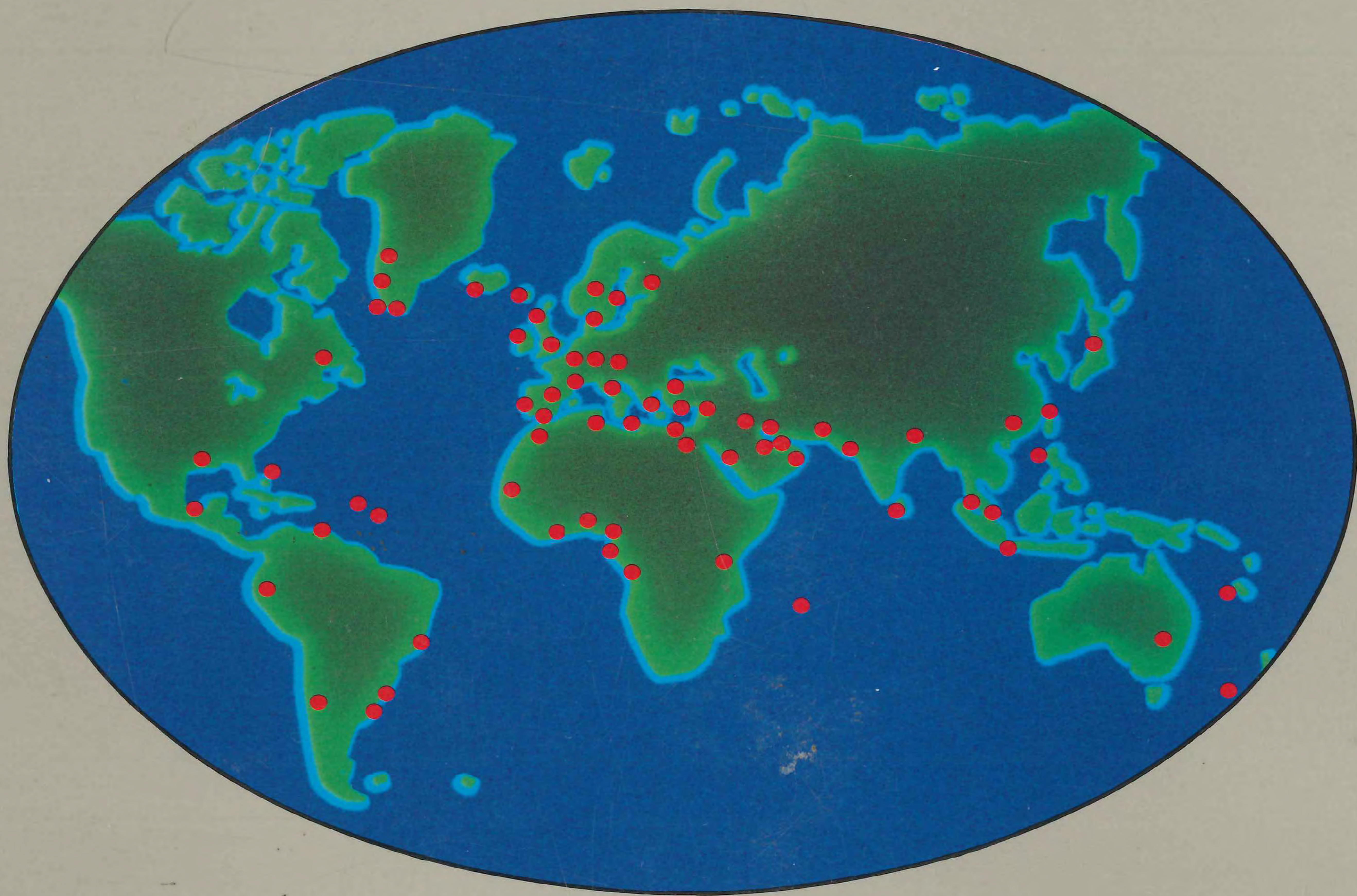

HF SSB
PROGRAMME
600 WATT PEP





S.P. RADIO A/S

PORSVEJ 2
DK-9200 AALBORG SV · DENMARK
PHONE + 45 98 18 09 99 · TELEX: 69 789 SPRAD DK
TELEFAX + 45 98 18 67 17

SAILOR

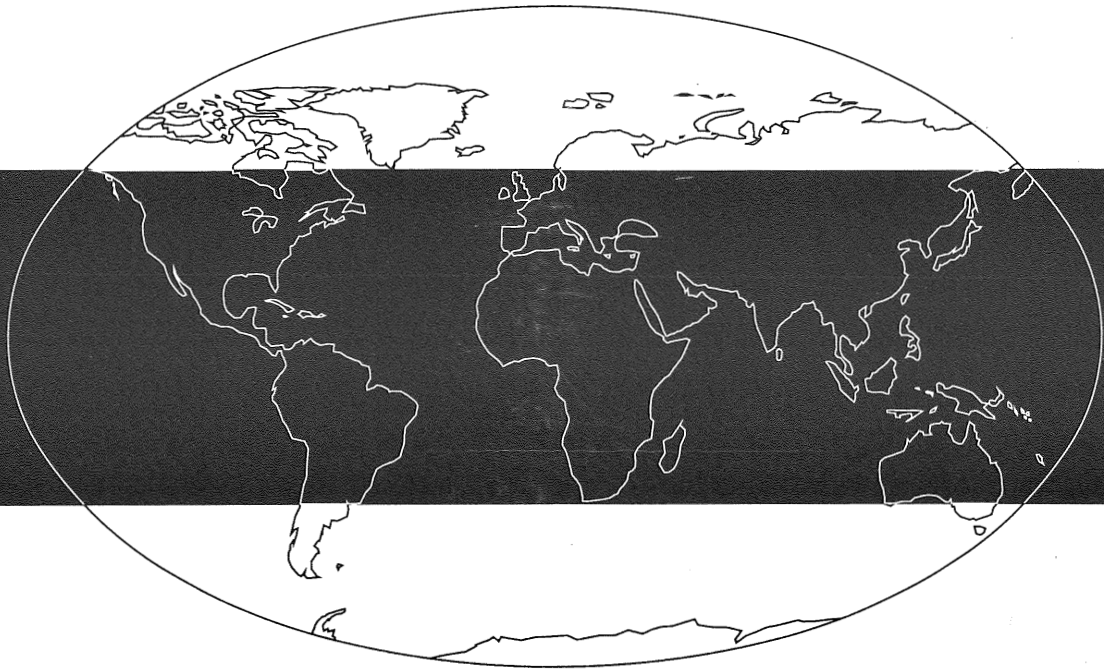

TECHNICAL MANUAL
FOR
HF SSB PROGRAMME 600W PEP



S.P. RADIO A/S · AALBORG · DENMARK



S.P. RADIO A/S

PORSVEJ 2 • DK-9200 AALBORG SV • DENMARK
TEL. INT. + 45 9818 0999 • TELEX 69 789 SPRAD DK • TELEFAX INT.+ 45 9818 6717

CONTENTS

PART I / 600W	TECHNICAL MANUAL FOR 600W PEP HF SSB SYSTEM
PART II	TECHNICAL MANUAL FOR TX-CONTROL UNIT
PART III	TECHNICAL MANUAL FOR POWER AMPLIFIER UNIT
PART IV	TECHNICAL MANUAL FOR COMBINER UNIT (ONLY IN 1200W)
PART V	TECHNICAL MANUAL FOR POWER SUPPLY UNIT 24V DC 600W
PART VI	TECHNICAL MANUAL FOR POWER SUPPLY UNIT 220V AC 600W
PART VII	TECHNICAL MANUAL FOR BATTERY CHARGER UNIT 220V AC 600W
AT2112	TECHNICAL MANUAL FOR AERIAL COUPLER AT2112

FOR YOUR INFORMATION

All information and illustrations in this manual are based on the information available when this manual was printed.

This edition is printed in december 1993.

We make reservations concerning errors in this manual, and specifikations are subjekt to change without further notice.

S.P.Radio A/S has the copyright, all rights are reserved. Copyright 1991, 1992 & 1993.

CONTENTS

1	GENERAL INFORMATION	
1.1	INTRODUCTION	1-1
1.2	DESCRIPTION OF SAILOR HF SSB PROGRAMME	1-1
1.3	TECHNICAL DATA	1-2
1.4	SYSTEM OVERVIEW	1-5
2	INSTALLATION	
2.1	DIMENSIONS AND DRILLING PLAN	2-1
2.2	INSTALLATION ELECTRICAL, BETWEEN CABINETS	2-2
2.3	BATTERY REQUIREMENTS FOR GMDSS	2-16
2.4	110/220V STRAPPING FOR T2131 - N2171 - N2174	2-17
3	SERVICE	
3.1	MAINTENANCE	3-1
3.2	ALIGNMENT INSTRUCTIONS	3-1
3.3	PROPOSAL FOR NECESSARY MEASURING INSTRUMENTS	3-1
3.4	TROUBLE SHOOTING	3-1
3.5	SYSTEM FUNCTION DESCRIPTION	3-7
3.6	PERFORMANCE CHECK	3-15
3.7	FUNCTION CHECK	3-17
3.8	SERVICE PROGRAMMES	3-18
4	MECHANICAL DESCRIPTION	
4.1	MECHANICAL ASSEMBLING / DISASSEMBLING AND UNITS LOCATION	4-1
5	CIRCUIT DESCRIPTION AND SCHEMATIC DIAGRAMS	
5.1	CONNECTION BOARD (MODULE 13) PART NO. 626413	5-1
5.2	CONNECTION BOARD (MODULE 5) PART NO. 626425	5-5
5.3	CONN. SINGLE BATTERY CHARGER (MODULE 3) PART NO. 626446	5-9
5.4	CONN. DUAL BATTERY CHARGER (MODULE 4) PART NO. 626447	5-13
5.5	REMOTE CONTROL UNIT H2180 FOR N2174 BATTERY CHARGER	5-17
5.6	FUSE BOX H2182	5-18
6	PARTS LISTS	

CONTENTS

1	GENERAL INFORMATION	1-1
1.1	INTRODUCTION	1-1
1.2	DESCRIPTION OF SAILOR HF SSB PROGRAMME	1-1
1.3	TECHNICAL DATA	1-2
1.4	SYSTEM OVERVIEW	1-5

1 GENERAL INFORMATION

1.1 INTRODUCTION

This instruction book consists of one general section with description down to unit level, and one section for each unit in the system with description of the units down to component level.

This section gives you all necessary information to install the system and make service down to unit level.

1.2 DESCRIPTION OF SAILOR HF SSB PROGRAMME

The SAILOR HF SSB programme is designed to meet all requirements within HF radio communication.

The SAILOR HF SSB programme consists of one main control unit and three transmitters with different power levels (250W, 600W, 1200W PEP).

To obtain maximum performance, the systems are designed with aerial couplers, which can be mounted outdoors. All the aerial couplers have automatic tuning.

Each of these three systems can be extended with:

- remote control units C2140
- telex/DSC scanning receiver with built-in modem RM2151
- DSC MF/HF watchkeeping receiver with built-in modem RM2150
- duplex receiver R2120

The system may be supplied for 24V DC or 110/220V AC power source.

For the system there are following battery chargers available:

- 30 amp battery charger N2174
- 3 x 30 amp battery charger 2 x N2174
- 60 amp battery charger N2174 Dual

These battery chargers can be used to charge maintenance free lead-acid batteries and Nickel Cadmium batteries.

The 600W PEP and 1200W PEP transmitters and power supplies are built up of the following units:

- 1) TX control unit, consisting of output filter, power supply, and audio amplifier for RE2100 and the TX-processor.
- 2) Power amplifier unit, consisting of a 600W power amplifier.
- 3) Combiner unit, consisting of power splitter and power combiner.
- 4) 24V DC power unit, consisting of a 24V DC to 28V and 42V DC switch mode power supply, which supplies the power amplifier unit.
- 5) 110/220V AC power supply unit, consisting of a 110/220V AC to 28V DC and 42V DC thyristor controlled power supply, which supplies the power amplifier unit.

1.3 TECHNICAL DATA

(Complies with SOLAS, ITU, CEPT, MPT, DOC, FTZ, KSR, FCC)

GENERAL

Frequency Range:	Receiver: 100 kHz to 30 MHz Transmitter: 1.6 MHz to 28 MHz
Modes:	J3E (USB/LSB), R3E, H3E and J2B.
Channel Capacity:	100 user defined quick-select channels and ITU defined channels in the maritime bands. Each channel contains both RX and TX frequency and mode settings.
Scanning Facilities:	10 scanning programmes, each able to contain 128 pairs of frequencies.
Distress Call:	Quick selection of 2182 kHz. Built-in two tone alarm: 1300 Hz and 2200 Hz with a duration of 45 secs.
Operating Temperature Range:	-15°C to +55°C
Frequency Stability:	Better than 0.34 ppm
Primary Voltage:	Depending on selected power supply.
Current Drain:	Depending on selected power supply.
Aerials:	Wire or whip aerials length 9 - 16 metres.

TRANSMITTER T2131

Power Output:	400 Watt PEP ± 1.4 dB 1.6MHz to 4MHz 600 Watt PEP ± 1.4 dB 4MHz to 16MHz 400 Watt PEP ± 1.4 dB 16MHz to 25MHz
Intermodulation:	Better than 32 dB below PEP
Spurious Emission:	Better than 67 dB below PEP
Harmonics:	Better than 43 dB below PEP or better than 67 dB below PEP with aerial coupler AT2112
Carrier Suppression:	Better than 46 dB below PEP
Audio Response:	350 Hz to 2700 Hz at -6 dB

RECEIVER RE2100

Receive System:	Double conversion super heterodyne 1st IF 70 MHz. 2nd 10.73 MHz
Selectivity:	J3E (SSB) 350 Hz to 2700 Hz at -6 dB H3E (AM) ± 3.3 kHz at -6 dB

Sensitivity:	J3E (SSB) <10 dB/uV for 20 dB SINAD H3E (AM) <24 dB/uV for 20 dB SINAD
Spurious and IF Rejection:	Better than -70 dB
Cross Modulation:	Better than 90 dB/uV (CEPT method of test)
Desensitization:	Better than 100 dB/uV (CEPT method of test)
AGC:	Less than 2 dB audio level change from 10 dB/uV to 80 dB/uV. Fast attack, slow release time.
Intermodulation:	Better than 90 dB/uV (CEPT method of test)
Spurious Emission:	Better than 1 nW into dummy aerial.
Clarifier:	±150 Hz in steps of 10 Hz.
Squelch:	Voice activated, opens for SINAD >6 dB.
Audio Power:	5 Watt in 8 ohm, or 10 Watt in 4 ohm, less than 10% distortion.

AERIAL COUPLER AT2112

Power:	1200W PEP
Aerial:	Wire or whip aerial, 9 - 16 metres length
Temperature Range:	-25°C to +70°C
Tuning Time:	Typical less than 2 secs.

POWER SUPPLIES 24V DC

Input Voltage:	21.6 Volt to 32 Volt
Current Drain:	Receive (standby) 2.5A Transmit voice 14A Telex (ARQ) 35A

POWER SUPPLIES 220V AC

Input Voltage:	220 Volt ±10% 50 Hz to 60 Hz 240 Volt ±10% 50 Hz to 60 Hz 110 Volt ±10% 50 Hz to 60 Hz
Current Drain:	Receive (standby) 0.5A, 220 Volt Transmit voice 1.7A, 220 Volt Telex (ARQ) 4.5A, 220 Volt

BATTERY CHARGERS**GENERAL**

Input voltage:	110V-127V-220V-240V AC +/- 10%
Input frequency:	48 - 65 Hz
Noise into Mains:	better than CEPT
Operating temperature:	-15°C to +55°C
On/Off and MAN/AUTO:	From external switches placed in remote box H2180 or in the console control H2192 where also meters for battery voltage and current are placed.
Trickle voltage (factory adjusted):	27.3V DC at 1A load, lead-acid batteries.
Upper level (factory adjusted):	28.8V DC, lead-acid batteries.
Sensor to monitor battery temp.:	Option

N2174 AUTOMATIC MODE

Output current (factory adjusted):	30A
Ripple voltage (rms) at 30A:	4%
Input current at full load:	8A, 220V

N2174 MANUAL MODE

Output voltage (adjustable):	29V DC at 1A load
Output current:	approx. 30A
Input current at full load:	8A, 220V

N2174 DUAL AUTOMATIC MODE

Output current (factory adjusted):	60A
Ripple voltage (rms) at 60A:	4%
Input current at full load:	16A, 220V

N2174 DUAL MANUAL MODE

Output voltage (adjustable):	29V DC at 1A load
Output current:	approx. 60A
Input current at full load:	16A, 220V

1.4 SYSTEM OVERVIEW

The 600W PEP transmitter T2131 is built-up of the following units:

TX CONTROL UNIT

Containing the output filters 1 to 6, filter switch, TX processor, power supply and AF amplifier.

PA UNIT

Containing one 600W power amplifier.

CONNECTION BOARD

With all the screw terminals for external connections.

POWER SUPPLY UNIT

Containing one 600W power supply for the 600W power amplifier unit.

All the above mentioned units are placed in one standard cabinet.

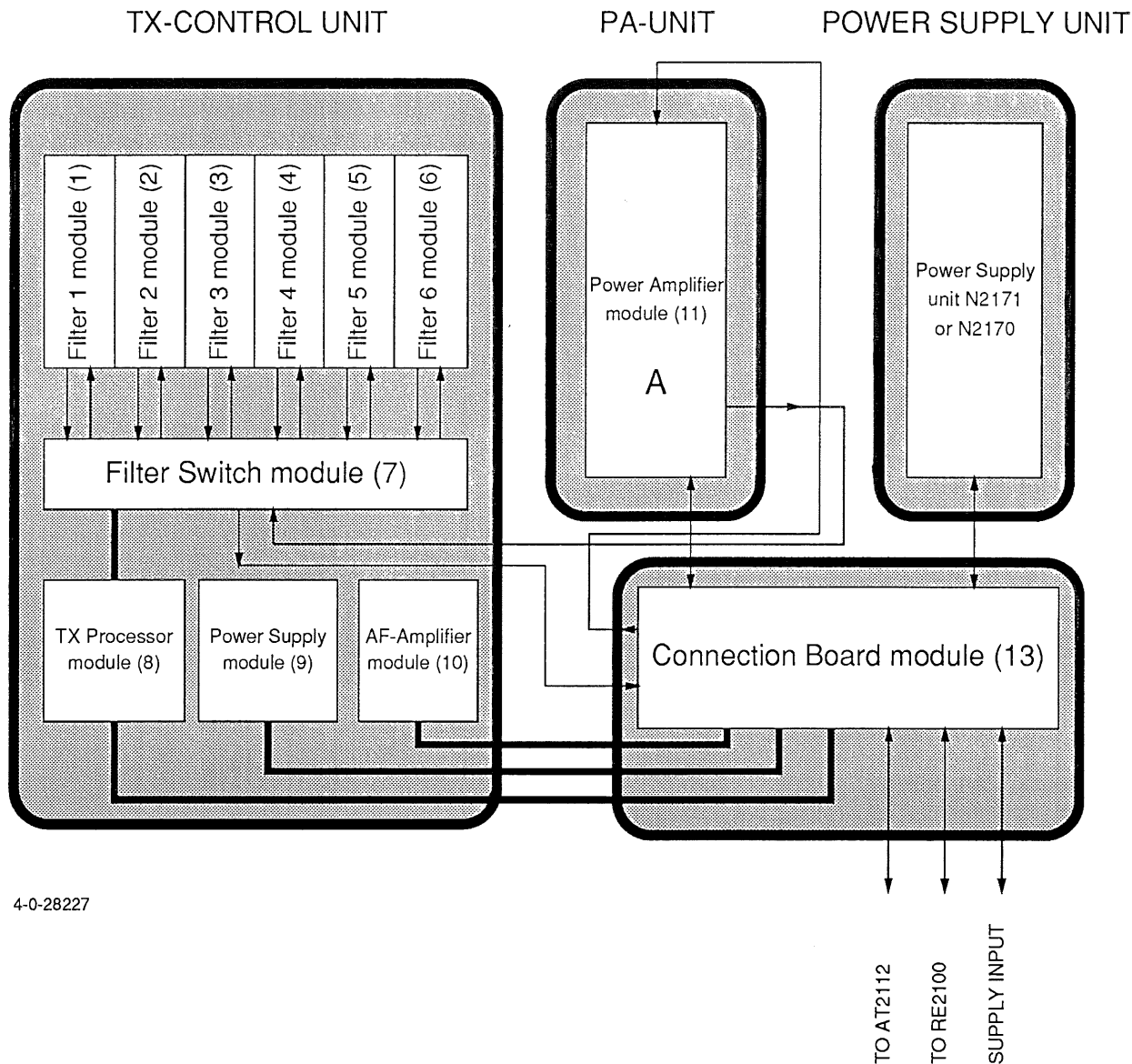

4-0-28227

CONTENTS

2	INSTALLATION	
2.1	DIMENSIONS AND DRILLING PLAN	2-1
2.2	INSTALLATION ELECTRICAL, BETWEEN CABINETS	2-2
2.3	BATTERY REQUIREMENTS FOR GMDSS	2-16
2.4	110/220V STRAPPING FOR T2131 - N2171 - N2174	2-17

2 INSTALLATION

2.1 DIMENSIONS AND DRILLING PLAN

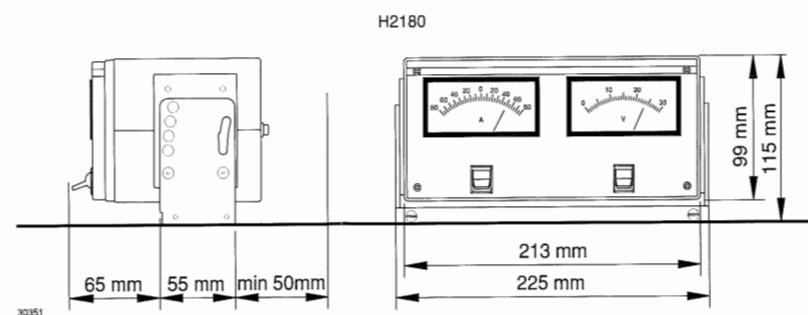
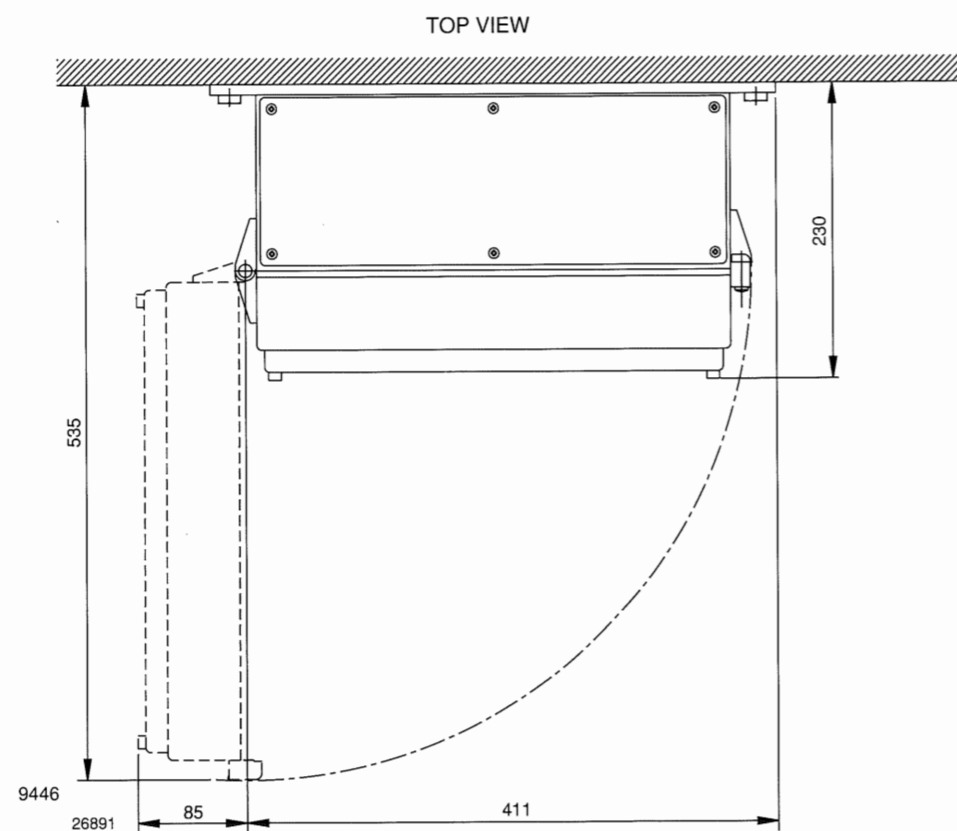
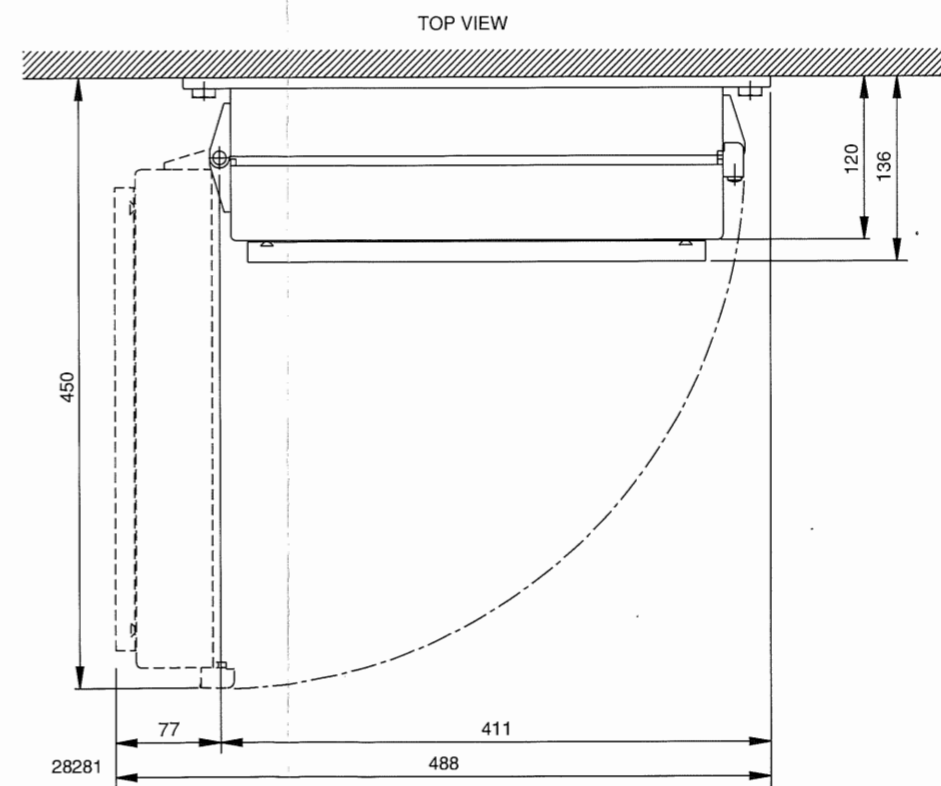
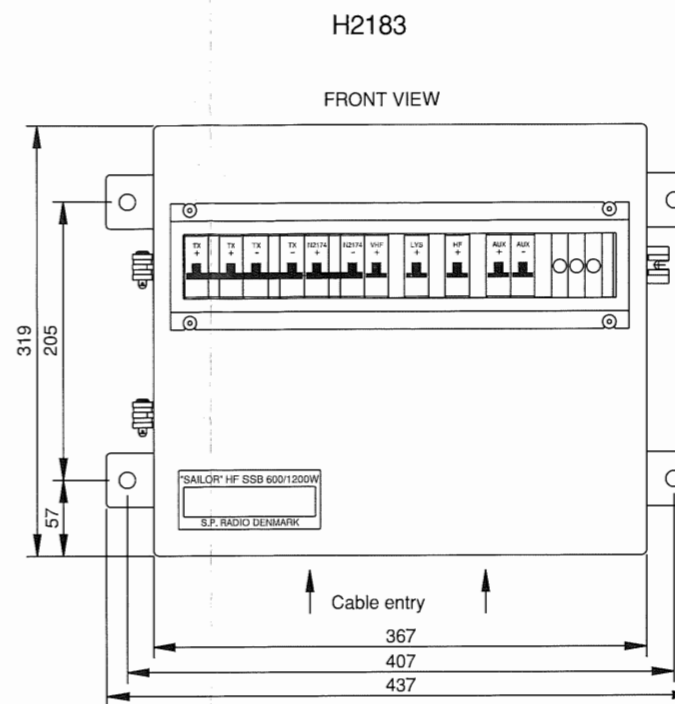
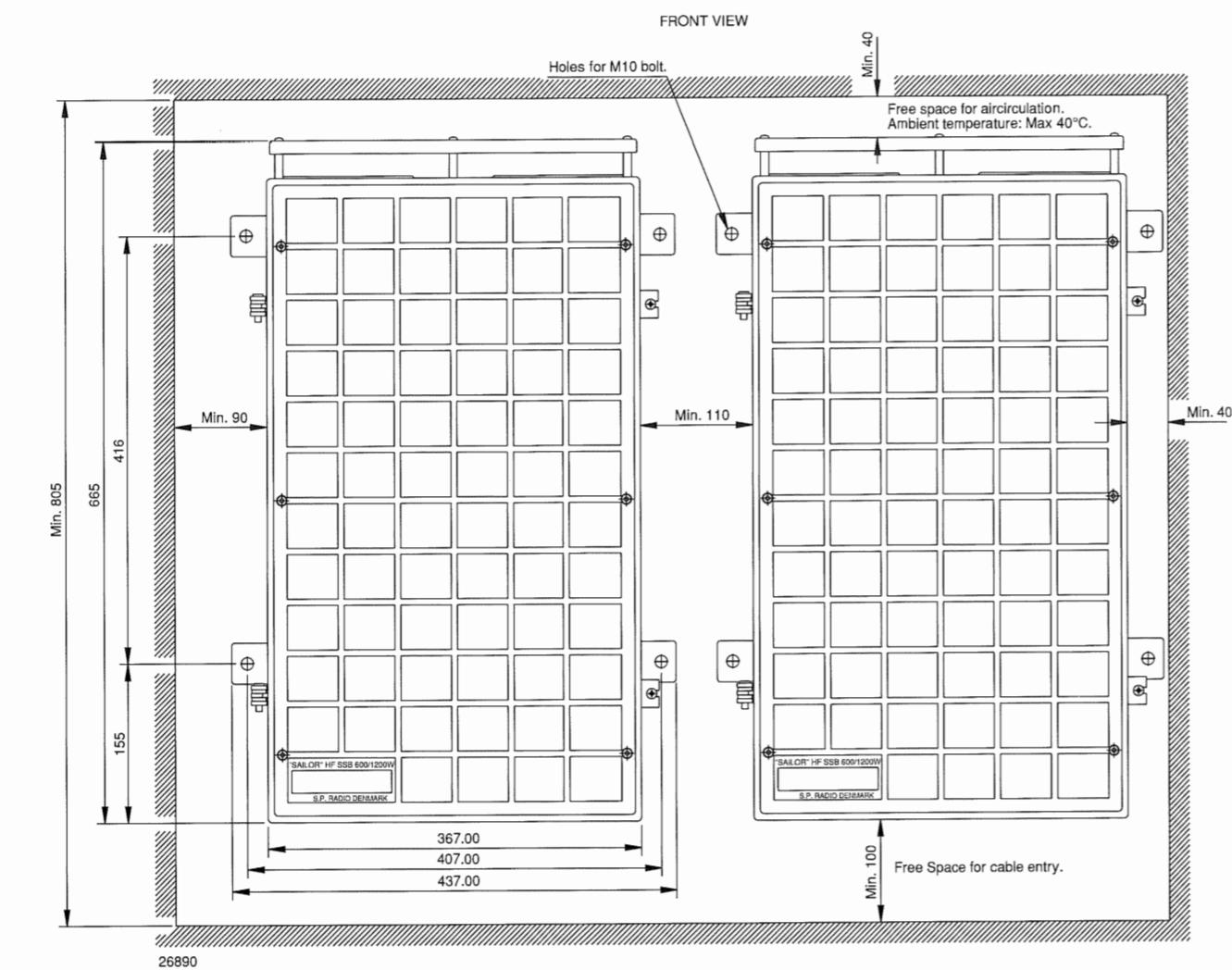

2.2 INSTALLATION ELECTRICAL, BETWEEN CABINETS

CABLE 1

AT2112 - T2131:

Multicable 16 x 0.5 mm², up to 100 metres

T2131	AT2112	SIGNAL
ST5	J1	
1	1	CONTROL 1
2	2	CONTROL 2
3	3	CONTROL 3
4	4	CONTROL 4
5	5	CONTROL 5
6	6	CONTROL 6
7	7	CONTROL 7
8	8	CONTROL 8
9	9	CONTROL 9
10	10	CONTROL 10
11	11	CONTROL 11
12	12	CONTROL 12
13	13	RX/TX
14	14	RX <4MHz
15	15	MOTOR
16	16	AE/180° PULSE

CABLE 5

RE2100 - T2131:

Factory supplied: 10 metres 21 x 0.5 mm² multicable max. length 30 metres.

T2131	RE2100	COLOUR	SIGNAL
ST6	P3-5		
1	1	BLACK	RX MUTE
2	15	YELLOW/BROW	VF/AE-CURRENT
3	11	VIOLET	+9V
4	12	GREY	+18V
5	13	WHITE	SUPPLY ON/OFF
6	14	PINK/BROWN	MIC KEY
7	2	BROWN	AF TO AMP COMMON
8	16	BROWN/GREEN	AF TO AMP
9	17	BROWN/GREY	0 dBm OUT COMMON
10	20	WHITE/GREEN	AUX AF TO TX
11	19	WHITE/YELLOW	EXT. RF CONTROL
12	18	WHITE/PINK	0 dBm OUT
13	21	WHITE/BLUE	TX-KEY
14	10	BLUE	-18V
15	25	RED/BLUE	-BATTERY
16	6	RED	SP-BUS INTERRUPT

CABLE 4

LOUDSPEAKER:

8 ohm, max. power 10W

T2131	LOUDSPEAKER
ST11	
1	GND
2	AF OUT
3	GND
4	AF OUT

CABLE 12

BATTERY TO N2170:

Current consumption: 60 Amp.

LENGTH IN METRES	2	3.2	5	8	10	13	16	24	34
CABLE DIMENSION	6	10	16	25	35	50	70	95	120

CABLE 15

SP-BUS:

RG58C/U coax cable max. length 100 meters.
Factory supplied: 10 meters RG58C/U coax cable marked blue.

CABLE 16

RF IN/OUT:

RG58C/U coax cable max. length 100 meters.
Factory supplied: 10 meters RG58C/U coax cable marked red.

CABLE 17

RF TO AT2112:

Triaxial cable H1213 max. length 200 meters.

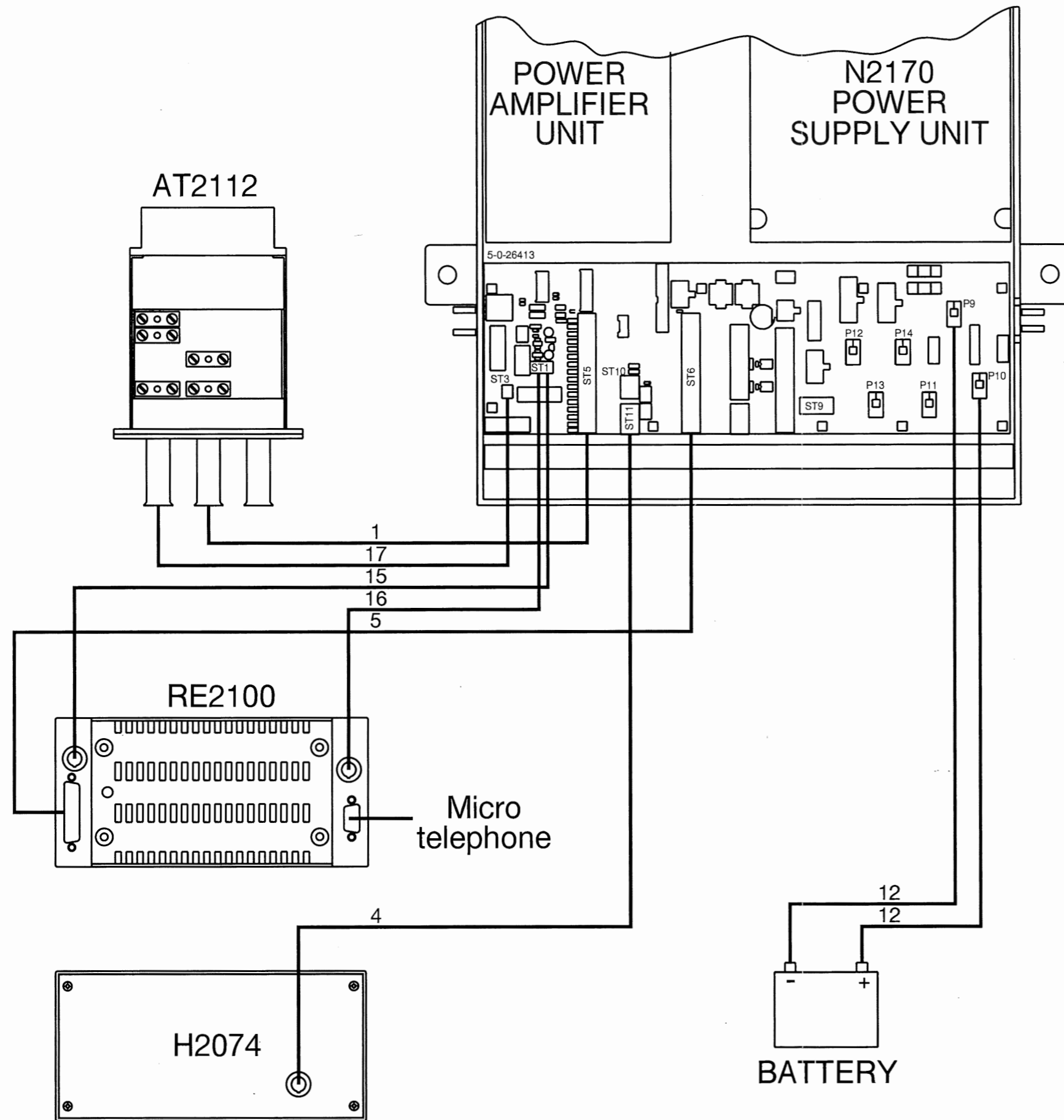

28112A

CABLE 1

AT2112 - T2131:

Multicable 16 x 0.5 mm², up to 100 metres

T2131	AT2112	SIGNAL
ST5	J1	
1	1	CONTROL 1
2	2	CONTROL 2
3	3	CONTROL 3
4	4	CONTROL 4
5	5	CONTROL 5
6	6	CONTROL 6
7	7	CONTROL 7
8	8	CONTROL 8
9	9	CONTROL 9
10	10	CONTROL 10
11	11	CONTROL 11
12	12	CONTROL 12
13	13	RX/TX
14	14	RX <4MHz
15	15	MOTOR
16	16	AE/180° PULSE

CABLE 4

LOUDSPEAKER:

8 ohm, max. power 10W

T2131	LOUDSPEAKER
ST11	
1	GND
2	AF OUT
3	GND
4	AF OUT

CABLE 5

RE2100 - T2131:

Factory supplied: 10 metres 21 x 0.5 mm² multicable max. length 30 metres.

T2131	RE2100	COLOUR	SIGNAL
ST6	P3-5		
1	1	BLACK	RX MUTE
2	15	YELLOW/BROW	VF/AE-CURRENT
3	11	VIOLET	+9V
4	12	GREY	+18V
5	13	WHITE	SUPPLY ON/OFF
6	14	PINK/BROWN	MIC KEY
7	2	BROWN	AF TO AMP COMMON
8	16	BROWN/GREEN	AF TO AMP
9	17	BROWN/GREY	0 dBm OUT COMMON
10	20	WHITE/GREEN	AUX AF TO TX
11	19	WHITE/YELLOW	EXT. RF CONTROL
12	18	WHITE/PINK	0 dBm OUT
13	21	WHITE/BLUE	TX-KEY
14	10	BLUE	-18V
15	25	RED/BLUE	-BATTERY
16	6	RED	SP-BUS INTERRUPT

CABLE 9

MAINS TO N2171:

220V MAINS: Current: approx 6 Amp.
Mains fuse min. 10 Amp.
3 x 1.5 mm² max. length 12 metres

110V MAINS: Current: approx 12 Amp.
Mains fuse min. 16 Amp.
3 x 2.5 mm² max. length 10 metres

T2131	SIGNAL
ST9	
1	GND
2	LIVE
3	NEUTRAL

CABLE 15

SP-BUS:

RG58C/U coax cable max. length 100 meters.
Factory supplied: 10 meters RG58C/U coax cable marked blue.

CABLE 16

RF IN/OUT:

RG58C/U coax cable max. length 100 meters.
Factory supplied: 10 meters RG58C/U coax cable marked red.

CABLE 17

RF TO AT2112:

Triaxial cable H1213 max. length 200 meters.

HF SSB 600W AC.

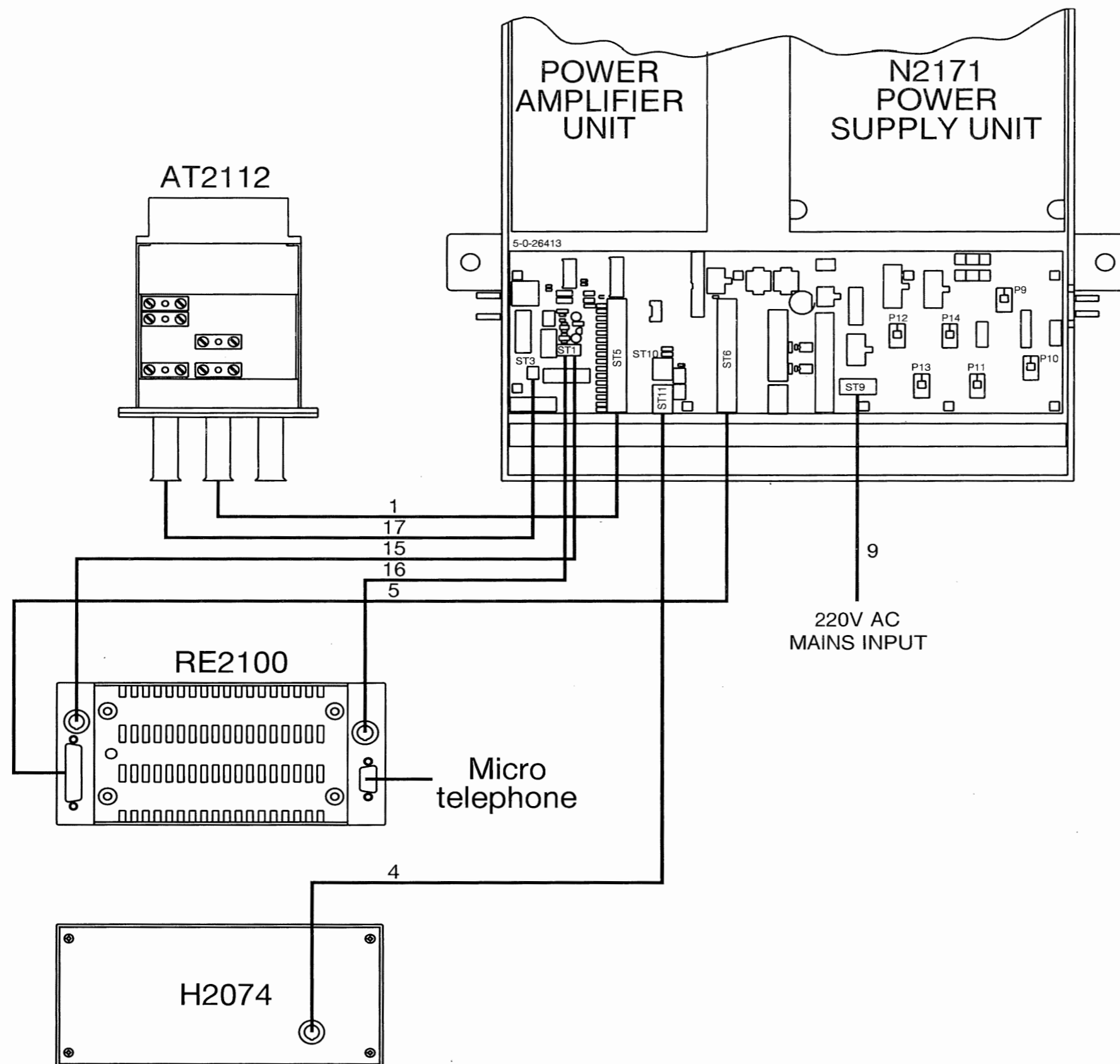

28111

9347

CABLE 1

AT2112 - T2131:

Multicable 16 x 0.5 mm², up to 100 metres

T2131	AT2112	SIGNAL
ST5	J1	
1	1	CONTROL 1
2	2	CONTROL 2
3	3	CONTROL 3
4	4	CONTROL 4
5	5	CONTROL 5
6	6	CONTROL 6
7	7	CONTROL 7
8	8	CONTROL 8
9	9	CONTROL 9
10	10	CONTROL 10
11	11	CONTROL 11
12	12	CONTROL 12
13	13	RX/TX
14	14	RX <4MHz
15	15	MOTOR
16	16	AE/180° PULSE

CABLE 4

LOUDSPEAKER:

8 ohm, max. power 10W

T2131	LOUDSPEAKER
ST11	
1	GND
2	AF OUT
3	GND
4	AF OUT

CABLE 5

RE2100 - T2131:

Factory supplied: 10 metres 21 x 0.5 mm² multicable max. length 30 metres.

T2131	RE2100	COLOUR	SIGNAL
ST6	P3-5		
1	1	BLACK	RX MUTE
2	15	YELLOW/BROW	VF/AE-CURRENT
3	11	VIOLET	+9V
4	12	GREY	+18V
5	13	WHITE	SUPPLY ON/OFF
6	14	PINK/BROWN	MIC KEY
7	2	BROWN	AF TO AMP COMMON
8	16	BROWN/GREEN	AF TO AMP
9	17	BROWN/GREY	0 dBm OUT COMMON
10	20	WHITE/GREEN	AUX AF TO TX
11	19	WHITE/YELLOW	EXT. RF CONTROL
12	18	WHITE/PINK	0 dBm OUT
13	21	WHITE/BLUE	TX-KEY
14	10	BLUE	-18V
15	25	RED/BLUE	-BATTERY
16	6	RED	SP-BUS INTERRUPT

CABLE 9

MAINS TO N2171:

220V MAINS: Current: approx 6 Amp.
Mains fuse min. 10 Amp.
3 x 1.5 mm² max. length 12 metres

110V MAINS: Current: approx 12 Amp.
Mains fuse min. 16 Amp.
3 x 2.5 mm² max. length 10 metres

T2131	SIGNAL
ST9	
1	GND
2	LIVE
3	NEUTRAL

CABLE 10

2170 TO T2131

+28V and GND: 4 mm² length max. 10 metres
+42V and GND cable dimension in mm²

LENGTH IN METRES	2.5	6	10
CABLE DIMENSION	4	10	16

CABLE 12

BATTERY TO N2170:

Current consumption: 60 Amp.

LENGTH IN METRES	2	3.2	5	8	10	13	16	24	34
CABLE DIMENSION	6	10	16	25	35	50	70	95	120

CABLE 15

SP-BUS:

RG58C/U coax cable max. length 100 meters.
Factory supplied: 10 meters RG58C/U coax cable marked blue.

CABLE 16

RF IN/OUT:

RG58C/U coax cable max. length 100 meters.
Factory supplied: 10 meters RG58C/U coax cable marked red.

CABLE 17

RF TO AT2112:

Triaxial cable H1213 max. length 200 meters.

CABLE 30

BATTERY TO T2131:

Note: N2170 is in a separate cabinet.
Use following cable: 2.5 mm² max. length 10 metres.

CABLE 36

N2170 - T2131

Multicable 3 x 0,18 mm² max. length 10 metres.

T2131	N2170	SIGNAL
ST10	ST3	
1	2	+18V
2	5	42V ON
3	6	28V ON

HF SSB 600W AC AND DC.

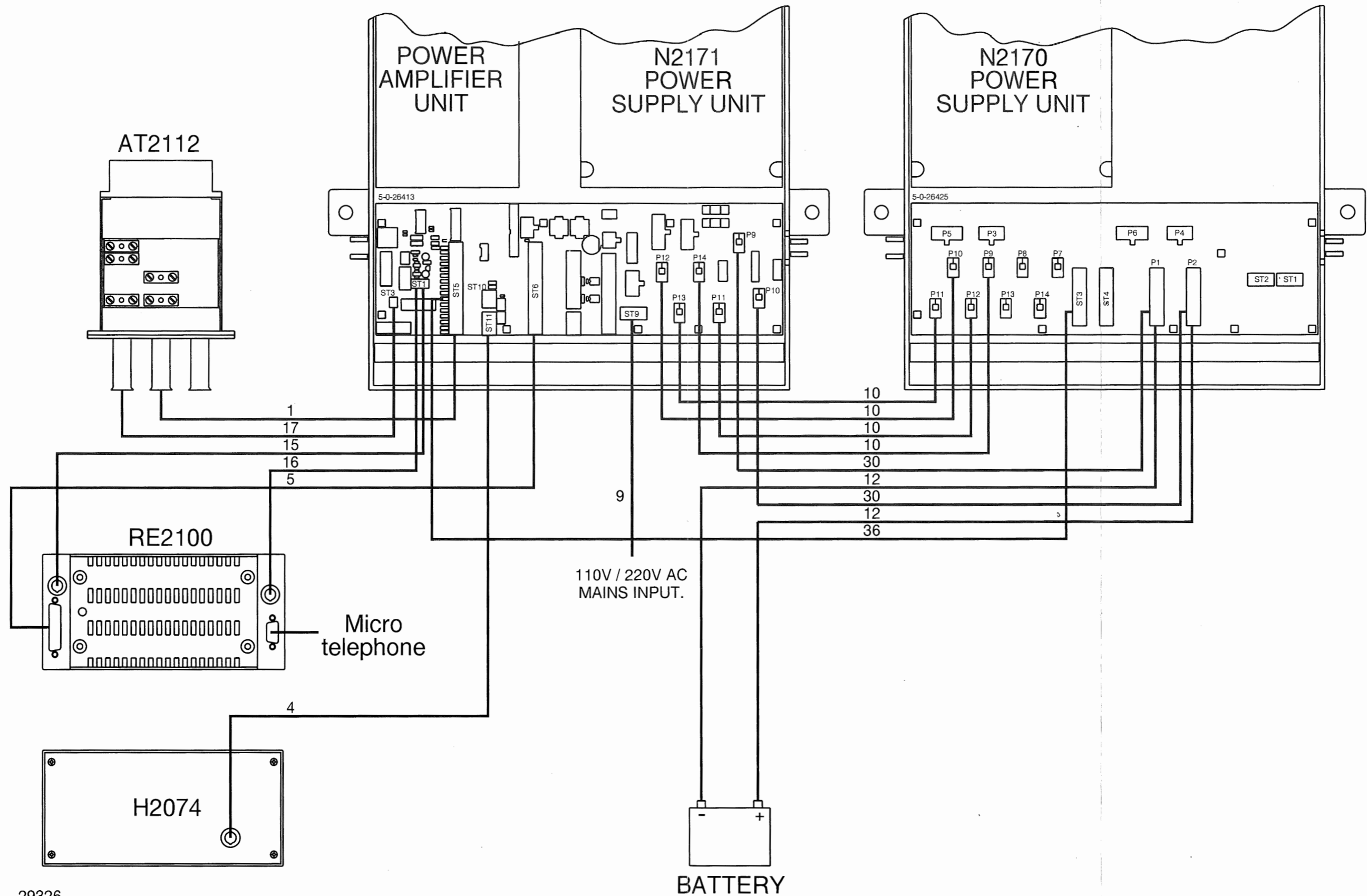

29326

CABLE 1

AT2112 - T2131:

Multicable 16 x 0.5 mm², up to 100 metres

T2131	AT2112	SIGNAL
ST5	J1	
1	1	CONTROL 1
2	2	CONTROL 2
3	3	CONTROL 3
4	4	CONTROL 4
5	5	CONTROL 5
6	6	CONTROL 6
7	7	CONTROL 7
8	8	CONTROL 8
9	9	CONTROL 9
10	10	CONTROL 10
11	11	CONTROL 11
12	12	CONTROL 12
13	13	RX/TX
14	14	RX <4MHz
15	15	MOTOR
16	16	AE/180° PULSE

CABLE 2

N2170 - T2131:

3 x 0.18 mm² multicable 10 metres.

T2131	N2170	SIGNAL
ST10	ST1	
1	1	+18V
2	2	42V ON DC
3	3	28V ON DC

CABLE 4

LOUDSPEAKER:

8 ohm, max. power 10W

T2131	LOUDSPEAKER
ST11	
1	GND
2	AF OUT
3	GND
4	AF OUT

CABLE 5

E2100 - T2131:

Factory supplied: 10 metres 21 x 0.5 mm² multicable max. length 30 metres.

T2131	RE2100	COLOUR	SIGNAL
ST6	P3-5		
1	1	BLACK	RX MUTE
2	15	YELLOW/BROW	VF/AE-CURRENT
3	11	VIOLET	+9V
4	12	GREY	+18V
5	13	WHITE	SUPPLY ON/OFF
6	14	PINK/BROWN	MIC KEY
7	2	BROWN	AF TO AMP COMMON
8	16	BROWN/GREEN	AF TO AMP
9	17	BROWN/GREY	0 dBm OUT COMMON
10	20	WHITE/GREEN	AUX AF TO TX
11	19	WHITE/YELLOW	EXT. RF CONTROL
12	18	WHITE/PINK	0 dBm OUT
13	21	WHITE/BLUE	TX-KEY
14	10	BLUE	-18V
15	25	RED/BLUE	-BATTERY
16	6	RED	SP-BUS INTERRUPT

CABLE 9

MAINS TO N2171:

220V MAINS: Current: approx 6 Amp.
Mains fuse min. 10 Amp.
3 x 1.5 mm² max. length 12 metres

110V MAINS: Current: approx 12 Amp.
Mains fuse min. 16 Amp.
3 x 2.5 mm² max. length 10 metres

T2131	SIGNAL
ST9	
1	GND
2	LIVE
3	NEUTRAL

CABLE 10

N2170 TO T2131

+28V and GND: 4 mm² length max. 10 metres
+42V and GND cable dimension in mm²

LENGTH IN METRES	2.5	6	10
CABLE DIMENSION	4	10	16

CABLE 12

BATTERY TO N2170:

Current consumption: 60 Amp.

LENGTH IN METRES	2	3.2	5	8	10	13	16	24	34
CABLE DIMENSION	6	10	16	25	35	50	70	95	120

CABLE 15

SP-BUS:

RG58C/U coax cable max. length 100 meters.
Factory supplied: 10 meters RG58C/U coax cable marked blue.

CABLE 16

RF IN/OUT:

RG58C/U coax cable max. length 100 meters.
Factory supplied: 10 meters RG58C/U coax cable marked red.

CABLE 17

RF TO AT2112:

Triaxial cable H1213 max. length 200 meters.

CABLE 18

MAINS TO N2174:

220V MAINS: Current: approx 8 Amp.
Mains fuses 16 Amp.
3 x 1.5 mm² max. length 12 metres

110V MAINS: Current: approx 16 Amp.
Mains fuses 25 Amp.
3 x 2.5 mm² max. length 10 metres

N2174	SIGNAL
ST2	
1	GND
2	LINE
3	NEUTRAL

CABLE 19

N2174 TO H2180:

Multicable: 6 x 0.75 mm² max. length 15 metres
Multicable: 6 x 1.5 mm² max. length 30 metres

N2174	H2180	SIGNAL
ST7		
1	1	- SHUNT
2	2	+ SHUNT
3	3	-VS
4	4	MAN
5	5	26V
6	6	AUTO

CABLE 20

N2174 TO H2182/H2183 (SHUNT):

4 x 1.0 mm² max. length 10 metres
4 x 2.5 mm² max. length 25 metres

N2174	SIGNAL
ST6	
1	- VS
2	+ VS
3	- SHUNT
4	+ SHUNT

CABLE 21

N2174 TO H2182/ (BATTERY):

+ BATT. and - BATT. cable dimensions in mm²
Current 30A

LENGTH IN METRES	8	13	22	30	40
CABLE DIMENSION	10	16	25	35	50

CABLE 22

H2182 TO BATTERY:

+ BATT. and - BATT. Cable dimensions in mm²
Current approx. 70A

LENGTH IN METRES	2.5	4	6	8	12
CABLE DIMENSION	16	25	35	50	70

CABLE 26

N2174 TO H2182/H2183 (Temperature sensor):

Multicable: 2 x 0.5 mm² max. length 50 metres

N2174	SIGNAL
ST4	
1	-TS
2	+TS

CABLE 30

BATTERY TO T2131:

Note: N2170 is in a separate cabinet.

Use following cable: 2.5 mm² max. length 10 metres.

50 eingebaut

HF SSB 600W DC AND AC WITH 30 AMP BATTERY CHARGER.

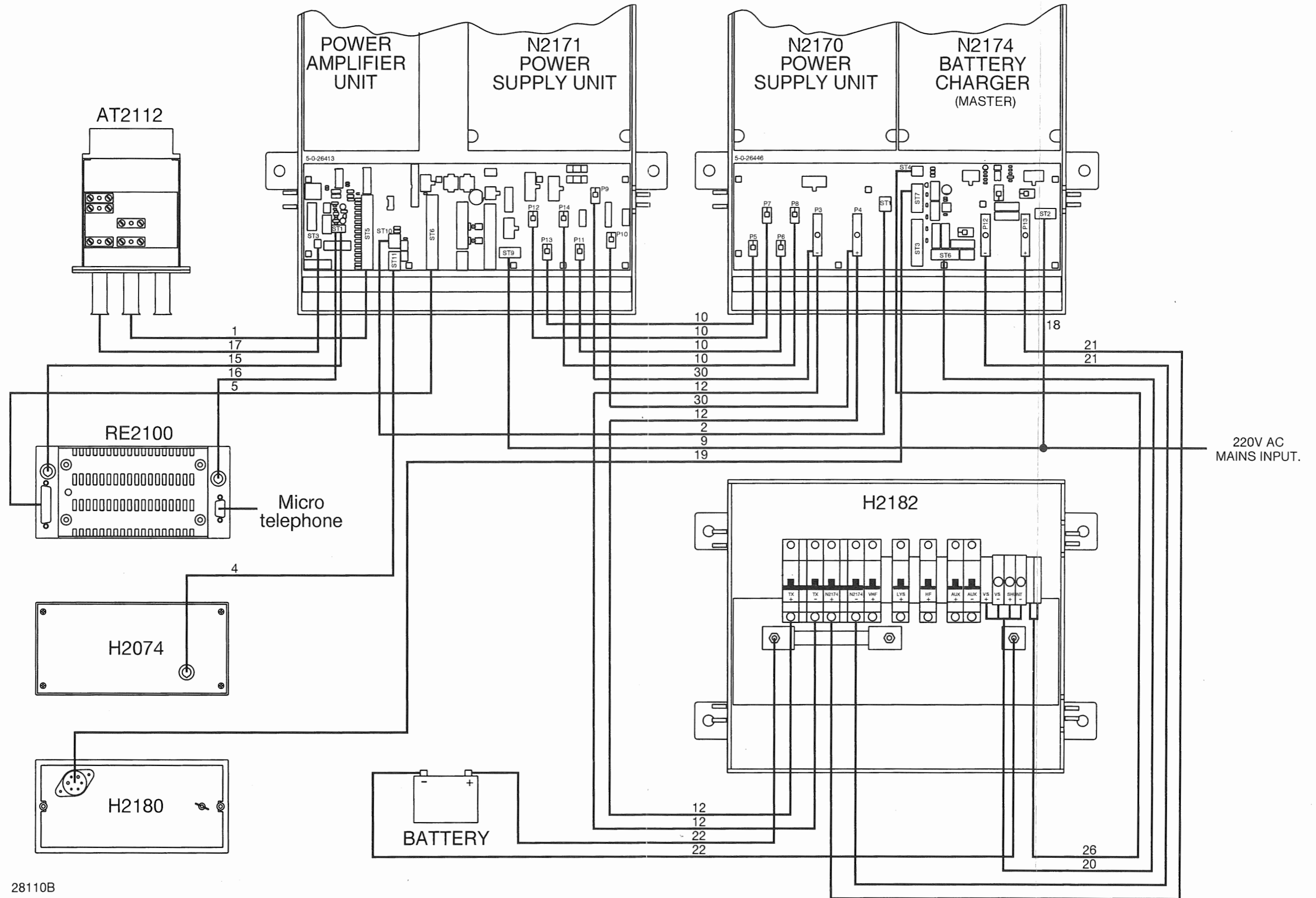

28110B

CABLE 1

AT2112 - T2131:

Multicable 16 x 0.5 mm², up to 100 metres

T2131	AT2112	SIGNAL
ST5	J1	
1	1	CONTROL 1
2	2	CONTROL 2
3	3	CONTROL 3
4	4	CONTROL 4
5	5	CONTROL 5
6	6	CONTROL 6
7	7	CONTROL 7
8	8	CONTROL 8
9	9	CONTROL 9
10	10	CONTROL 10
11	11	CONTROL 11
12	12	CONTROL 12
13	13	RX/TX
14	14	RX <4MHz
15	15	MOTOR
16	16	AE/180° PULSE

CABLE 4

LOUDSPEAKER:

8 ohm, max. power 10W

T2131	LOUDSPEAKER
ST11	
1	GND
2	AF OUT
3	GND
4	AF OUT

CABLE 5

RE2100 - T2131:

Factory supplied: 10 metres 21 x 0.5 mm² multicable max. length 30 metres.

T2131	RE2100	COLOUR	SIGNAL
ST6	P3-5		
1	1	BLACK	RX MUTE
2	15	YELLOW/BROW	VF/AE-CURRENT
3	11	VIOLET	+9V
4	12	GREY	+18V
5	13	WHITE	SUPPLY ON/OFF
6	14	PINK/BROWN	MIC KEY
7	2	BROWN	AF TO AMP COMMON
8	16	BROWN/GREEN	AF TO AMP
9	17	BROWN/GREY	0 dBm OUT COMMON
10	20	WHITE/GREEN	AUX AF TO TX
11	19	WHITE/YELLOW	EXT. RF CONTROL
12	18	WHITE/PINK	0 dBm OUT
13	21	WHITE/BLUE	TX-KEY
14	10	BLUE	-18V
15	25	RED/BLUE	-BATTERY
16	6	RED	SP-BUS INTERRUPT

CABLE 12

BATTERY TO N2170:

Current consumption: 60 Amp.

LENGTH IN METRES	2	3.2	5	8	10	13	16	24	34
CABLE DIMENSION	6	10	16	25	35	50	70	95	120

CABLE 15

SP-BUS:

RG58C/U coax cable max. length 100 meters. Factory supplied: 10 meters RG58C/U coax cable marked blue.

CABLE 16

RF IN/OUT:

RG58C/U coax cable max. length 100 meters. Factory supplied: 10 meters RG58C/U coax cable marked red.

CABLE 17

RF TO AT2112:

Triaxial cable H1213 max. length 200 meters.

CABLE 22

H2182 TO BATTERY:

+ BATT. and - BATT. Cable dimensions in mm² Current approx. 70A

LENGTH IN METRES	2.5	4	6	8	12
CABLE DIMENSION	16	25	35	50	70

CABLE 23

N2174 TO N2174 (for dual operation):

+ OUTPUT. and - OUTPUT. Cable dimensions 6 mm² Current approx. 30A. max. length 2 metres

N2174-I	N2174-II	SIGNAL
P5	P11	- OUTPUT
P6	P12	+ OUTPUT

CABLE 24

N2174 DUAL TO H2183 / BATTERY:

+ BATT. and - BATT. Cable dimensions in mm² Current 60A.

LENGTH IN METRES	6	10	14	22	30
CABLE DIMENSION	16	25	35	50	70

CABLE 25

N2174 TO N2174 / (Control signals):

Factory mounted Multicable: 5 x 0.5 mm² max. length 30 metres

N2174-I	N2174-II	SIGNAL
ST5 pin 4	ST11 pin 4	MAN
ST5 pin 6	ST11 pin 6	AUTO
ST5 pin 1	ST11 pin 1	- SHUNT
ST5 pin 3	ST11 pin 3	- VS
ST1 pin 10	ST7 pin 10	M/S

CABLE 31

MAINS TO N2174:

220V MAINS: Current: approx 8 Amp. Mains fuses 16 Amp. 3 x 1.5 mm² max. length 12 metres

110V MAINS: Current: approx 16 Amp. Mains fuses 25 Amp. 3 x 2.5 mm² max. length 10 metres

N2174	SIGNAL
ST6	
1	GND
2	LINE
3	NEUTRAL

CABLE 32

N2174 TO H2180:

Multicable: 6 x 0.75 mm² max. length 15 metres Multicable: 6 x 1.5 mm² max. length 30 metres

N2174	H2180	SIGNAL
ST11		
1	1	- SHUNT
2	2	+ SHUNT
3	3	-VS
4	4	MAN
5	5	26V
6	6	AUTO

CABLE 33

N2174 TO H2183 (SHUNT):

4 x 1.0 mm² max. length 10 metres 4 x 2.5 mm² max. length 25 metres

N2174	SIGNAL
ST10	
1	- VS
2	+ VS
3	- SHUNT
4	+ SHUNT

CABLE 34

N2174 TO H2182 / (Temperature sensor):

Multicable: 2 x 0.5 mm² max. length 50 metres

N2174	SIGNAL
ST8	
1	-TS
2	+TS

CABLE 41

MAINS TO N2174:

220V MAINS: Current: approx 8 Amp. Mains fuses 16 Amp. 3 x 1.5 mm² max. length 12 metres

110V MAINS: Current: approx 16 Amp. Mains fuses 25 Amp. 3 x 2.5 mm² max. length 10 metres

N2174	SIGNAL
ST12	
1	GND
2	LINE
3	NEUTRAL

HF SSB 600W DC WITH 60 AMP BATTERY CHARGER.

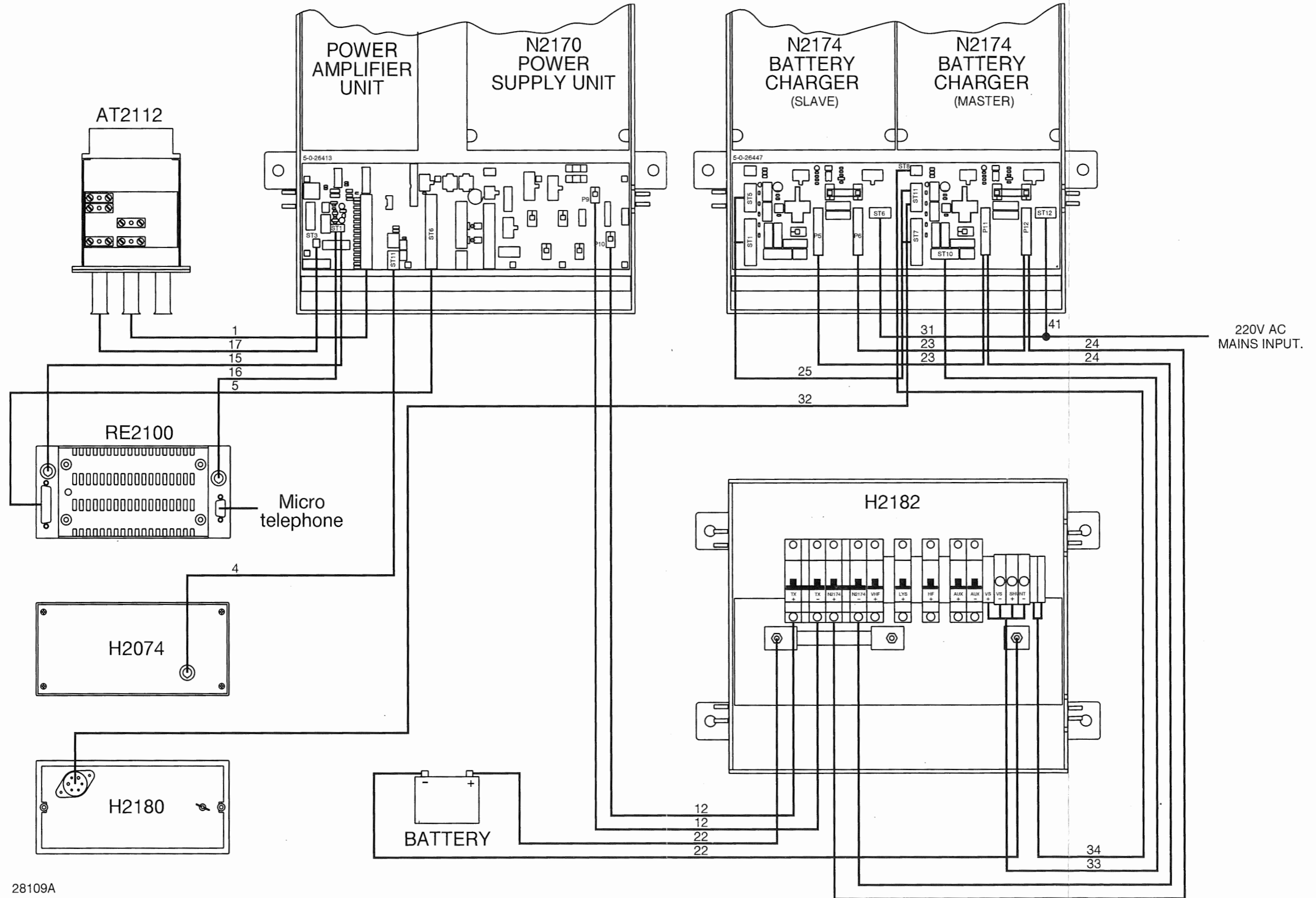

28109A

CABLE 1

AT2112 - T2131:

Multicable 16 x 0.5 mm², up to 100 metres

T2131	AT2112	SIGNAL
ST5	J1	
1	1	CONTROL 1
2	2	CONTROL 2
3	3	CONTROL 3
4	4	CONTROL 4
5	5	CONTROL 5
6	6	CONTROL 6
7	7	CONTROL 7
8	8	CONTROL 8
9	9	CONTROL 9
10	10	CONTROL 10
11	11	CONTROL 11
12	12	CONTROL 12
13	13	RX/TX
14	14	RX <4MHz
15	15	MOTOR
16	16	AE/180° PULSE

CABLE 2

N2170 - T2131:

3 x 0.18 mm² multicable 10 metres.

T2131	N2170	SIGNAL
ST10	ST1	
1	1	+18V
2	2	42V ON DC
3	3	28V ON DC

CABLE 4

LOUDSPEAKER:

8 ohm, max. power 10W

T2131	LOUDSPEAKER
ST11	
1	GND
2	AF OUT
3	GND
4	AF OUT

CABLE 5

RE2100 - T2131:

Factory supplied: 10 metres 21 x 0.5 mm² multicable max. length 30 metres,

T2131	RE2100	COLOUR	SIGNAL
ST6	P3-5		
1	1	BLACK	RX MUTE
2	15	YELLOW/BROW	VF/AE-CURRENT
3	11	VIOLET	+9V
4	12	GREY	+18V
5	13	WHITE	SUPPLY ON/OFF
6	14	PINK/BROWN	MIC KEY
7	2	BROWN	AF TO AMP COMMON
8	16	BROWN/GREEN	AF TO AMP
9	17	BROWN/GREY	0 dBm OUT COMMON
10	20	WHITE/GREEN	AUX AF TO TX
11	19	WHITE/YELLOW	EXT. RF CONTROL
12	18	WHITE/PINK	0 dBm OUT
13	21	WHITE/BLUE	TX-KEY
14	10	BLUE	-18V
15	25	RED/BLUE	-BATTERY
16	6	RED	SP-BUS INTERRUPT

CABLE 6

C2140 - T2131:

10 x 0.5 mm² max. length 100 metres, see also instruction book for C2140.

T2131	C2140	SIGNAL
ST8	ST1	
1	1	AUX AF IN TX
2	2	AUX AF IN TX
3	3	0 dBm OUT
4	4	0 dBm OUT
5	5	EXT. RF-GAIN CONTROL
6	6	AE/SIGN CURRENT
7	7	SP-BUS INTERRUPT
8	8	GND
9	9	+28V
10	10	GND

CABLE 7

MUTE:

MUTE OUT: Relay contact closed when transmitting.
Max. ratings: 30V/2A

MUTE RX IN: Relay coil:Max. voltage:35V, 20°C
Min. voltage: 9V, 20°C
2250 ohm ±300 ohm

T2131	SIGNAL
ST12	
1	MUTE OUT
2	MUTE OUT
3	MUTE RX IN
4	MUTE RX IN

CABLE 8

RM2150/RM2151 - T2131:

HT-ON: AUX AF TO TX:

Optocoupler: 12V < V_{in} high < 15V
25mA < I_{in} high < 35mA
-1V < V_{in} low < 2V

Transformer: Impedance 600ohm
Level -6 dBm to 10 dBm

TX KEY: 0 dBm OUT:

Optocoupler: 12V < V_{in} high < 22V
10 mA < I_{in} high < 20mA
-1V < V_{in} low < 2V

Transformer: Impedance 600 ohm
Level 0 dBm

T2131	RM2150/51	COLOUR	SIGNAL
ST7	P2-5		
1	11	GREY	+9V
2	12	WHITE	+18V
3	10	VIOLET	-18V
4	13	BROWN/PINK	SUPPLY ON/OFF
5	25	RED/BLUE	-BATT
6	-	-	HT ON-
7	-	-	HT ON+
8	15	BROWN/GREEN	TX-KEY-
* 9 / 2	-	-	TX-KEY+
10	18	WHITE/YELLOW	AUX AF TO TX
11	9	BLUE	AUX AF TO TX
12	6	YELLOW	SP-BUS INTERRUPT
13	-	-	SPARE
14	-	-	SPARE

* Mount a wire between pin 9 and pin 2

CABLE 9

MAINS TO N2171:

220V MAINS: Current: approx 6 Amp.
Mains fuse min. 10 Amp.
3 x 1.5 mm² max. length 12 metres

110V MAINS: Current: approx 12 Amp.
Mains fuse min. 16 Amp.
3 x 2.5 mm² max. length 10 metres

T2131	SIGNAL
ST9	
1	GND
2	LIVE
3	NEUTRAL

CABLE 10

N2170 TO T2131

+28V and GND: 4 mm² length max. 10 metres

+42V and GND cable dimension in mm²

LENGTH IN METRES	2.5	6	10
CABLE DIMENSION	4	10	16

CABLE 12

BATTERY TO T2170:

Current consumption: 60 Amp.

LENGTH IN METRES	2	3.2	5	8	10	13	16	24	34
CABLE DIMENSION	6	10	16	25	35	50	70	95	120

CABLE 15

SP-BUS:

RG58C/U coax cable max. length 100 meters.
Factory supplied: 10 meters RG58C/U coax cable marked blue.

CABLE 16

RF IN/OUT:

RG58C/U coax cable max. length 100 meters.
Factory supplied: 10 meters RG58C/U coax cable marked red.

CABLE 17

RF TO AT2112:

Triaxial cable H1213 max. length 200 meters.

CABLE 30

BATTERY TO T2131:

Note: N2170 is in a separate cabinet.

Use following cable: 2.5 mm² max. length 10 metres.

CONNECTION TO T2131

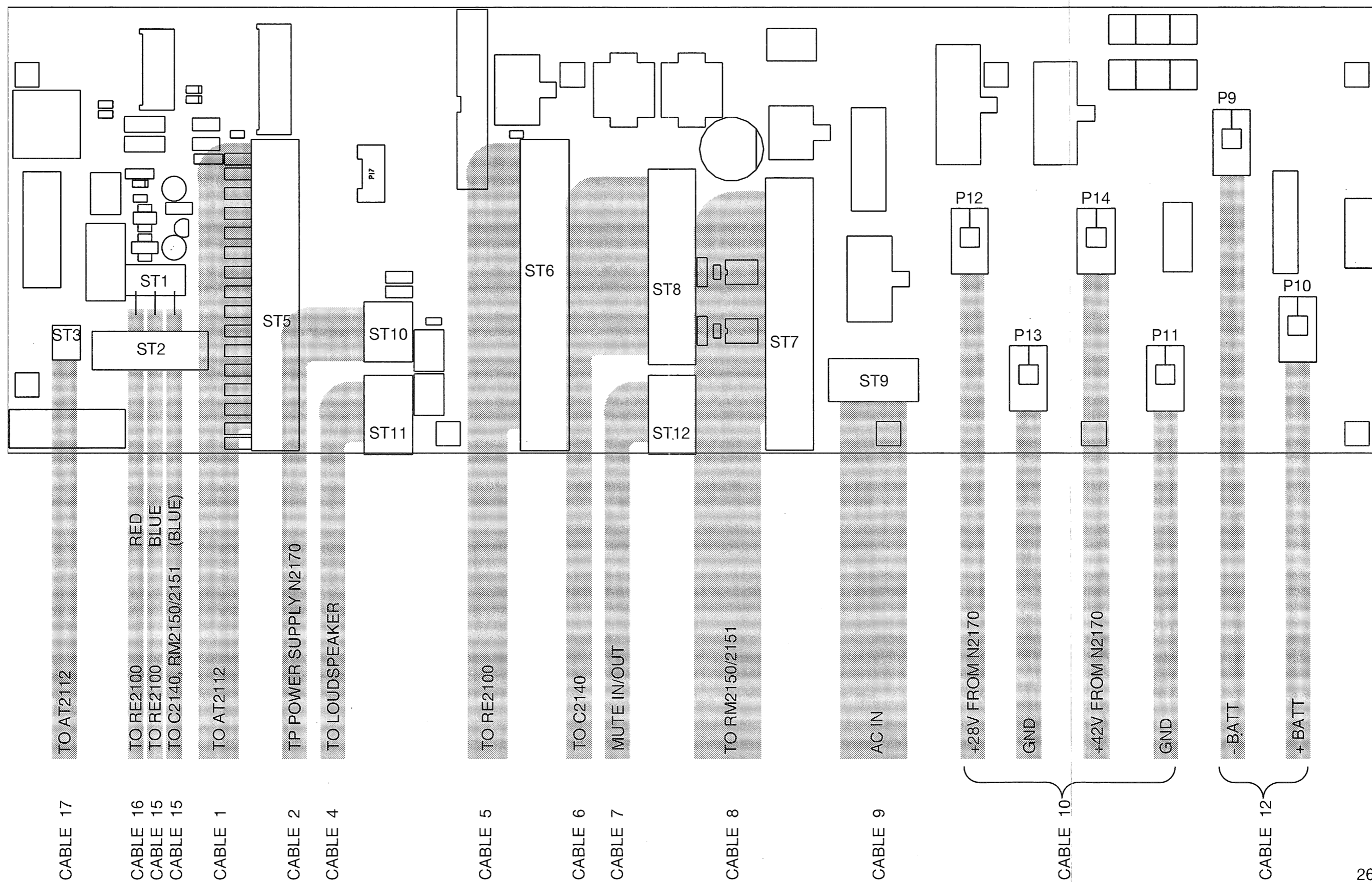

CABLE 10 N2170 TO T2131

+28V and GND: 4 mm² length max. 10 metres
+42V and GND cable dimension in mm²

LENGTH IN METRES	2.5	6	10
CABLE DIMENSION	4	10	16

CABLE 18 TO N2174:

220V MAINS: Current: approx 8 Amp.
Mains fuses 16 Amp.
3 x 1.5 mm² max. length 12 metres

110V MAINS: Current: approx 16 Amp.
Mains fuses 25 Amp.
3 x 2.5 mm² max. length 10 metres

N2174	SIGNAL
ST2	
1	GND
2	LINE
3	NEUTRAL

CABLE 19 N2174 TO H2180:

Multicable: 6 x 0.75 mm² max. length 15 metres
Multicable: 6 x 1.5 mm² max. length 30 metres

N2174	H2180	SIGNAL
ST7		
1	1	- SHUNT
2	2	+ SHUNT
3	3	-VS
4	4	MAN
5	5	26V
6	6	AUTO

CABLE 20 N2174 TO H2182/H2183 (SHUNT):

4 x 1.0 mm² max. length 10 metres
4 x 2.5 mm² max. length 25 metres

N2174	SIGNAL
ST6	
1	- VS
2	+ VS
3	- SHUNT
4	+ SHUNT

CABLE 21 N2174 TO H2182 / (BATTERY):

+ BATT. and - BATT. cable dimensions in mm²
Current 30 A

LENGTH IN METRES	8	13	22	30	40
CABLE DIMENSION	10	16	25	35	50

CABLE 23 N2174 TO N2174 (for dual operation):
+ OUTPUT. and - OUTPUT. Cable dimensions in mm²
Current approx. 30A. max. length 2 metres

N2174-I	N2174-II	SIGNAL
P5	P11	- OUTPUT
P6	P12	+ OUTPUT

CABLE 24 N2174 DUAL TO H2183 / BATTERY:

+ BATT. and - BATT. Cable dimensions in mm²
Current 60A.

LENGTH IN METRES	6	10	14	22	30
CABLE DIMENSION	16	25	35	50	70

CABLE 25 N2174 TO N2174 / (Control signals):

Factory mounted
Multicable: 5 x 0.5 mm² max. length 30 metres

N2174-I	N2174-II	SIGNAL
ST5 pin 4	ST11 pin 4	MAN
ST5 pin 6	ST11 pin 6	AUTO
ST5 pin 1	ST11 pin 1	- SHUNT
ST5 pin 3	ST11 pin 3	- VS
ST1 pin 10	ST7 pin 10	M/S

CABLE 26 N2174 TO H2182/H2183

(Temperature sensor):

Multicable: 2 x 0.5 mm² max. length 50 metres

N2174	SIGNAL
ST4	
1	-TS
2	+TS

CABLE 27 N2174 TO EXT. ALARM:

Multicable: 9 x 0.5 mm² max. length 50 metres
Current max. 1A
See diagrams chapter 5.3 or 5.4

CABLE 29 N2174 TO AUX. OUTPUT:

2 x 2.5 mm² Cable max. length 10 metres
Current max. 6A

N2174	SIGNAL
ST5	
1	-BATT
2	+BATT

CABLE 31 MAINS TO N2174:

220V MAINS: Current: approx 8 Amp.
Mains fuses 16 Amp.
3 x 1.5 mm² max. length 12 metres

110V MAINS: Current: approx 16 Amp.
Mains fuses 25 Amp.
3 x 2.5 mm² max. length 10 metres

N2174	SIGNAL
ST6	
1	GND
2	LINE
3	NEUTRAL

CABLE 32 N2174 TO H2180:

Multicable: 6 x 0.75 mm² max. length 15 metres
Multicable: 6 x 1.5 mm² max. length 30 metres

N2174	H2180	SIGNAL
ST11		
1	1	- SHUNT
2	2	+ SHUNT
3	3	-VS
4	4	MAN
5	5	26V
6	6	AUTO

CABLE 34

N2174 TO H2182 / (Temperature sensor):

Multicable: 2 x 0.5 mm² max. length 50 metres

N2174	SIGNAL
ST8	
1	-TS
2	+TS

CABLE 35 N2174 TO H2180:

Multicable: 6 x 0.75 mm² max. length 15 metres
Multicable: 6 x 1.5 mm² max. length 30 metres

N2174	H2180	SIGNAL
ST5		
1	1	- SHUNT
2	2	+ SHUNT
3	3	-VS
4	4	MAN
5	5	26V
6	6	AUTO

CABLE 37

N2174 TO H2182/H2183 (SHUNT):

4 x 1.0 mm² max. length 10 metres
4 x 2.5 mm² max. length 25 metres

N2174	SIGNAL
ST10	
1	-VS
2	+VS
3	SHUNT
4	SHUNT

CABLE 38 N2174 TO H2182/H2183 (SHUNT):

4 x 1.0 mm² max. length 10 metres
4 x 2.5 mm² max. length 25 metres

N2174	SIGNAL
ST4	
1	-VS
2	+VS
3	SHUNT
4	SHUNT

CABLE 40 N2174 TO H2182/H2183

(Temperature sensor):

Multicable: 2 x 0.5 mm² max. length 50 metres

N2174	SIGNAL
ST2	
1	-TS
2	+TS

CABLE 41 MAINS TO N2174:

220V MAINS: Current: approx 8 Amp.
Mains fuses 16 Amp.
3 x 1.5 mm² max. length 12 metres

110V MAINS: Current: approx 16 Amp.
Mains fuses 25 Amp.
3 x 2.5 mm² max. length 10 metres

N2174	SIGNAL
ST12	
1	GND
2	LINE
3	NEUTRAL

CABLE 45 N2174 TO AUX. OUTPUT:

2 x 2.5 mm² Cable max. length 10 metres
Current max. 6A

N2174	SIGNAL
ST3	
1	-BATT
2	+BATT

CABLE 49 N2174 TO AUX. OUTPUT:

2 x 2.5 mm² Cable max. length 10 metres
Current max. 6A

N2174	SIGNAL
ST9	
1	-BATT
2	+BATT

CONNECTION TO N2174 SINGLE

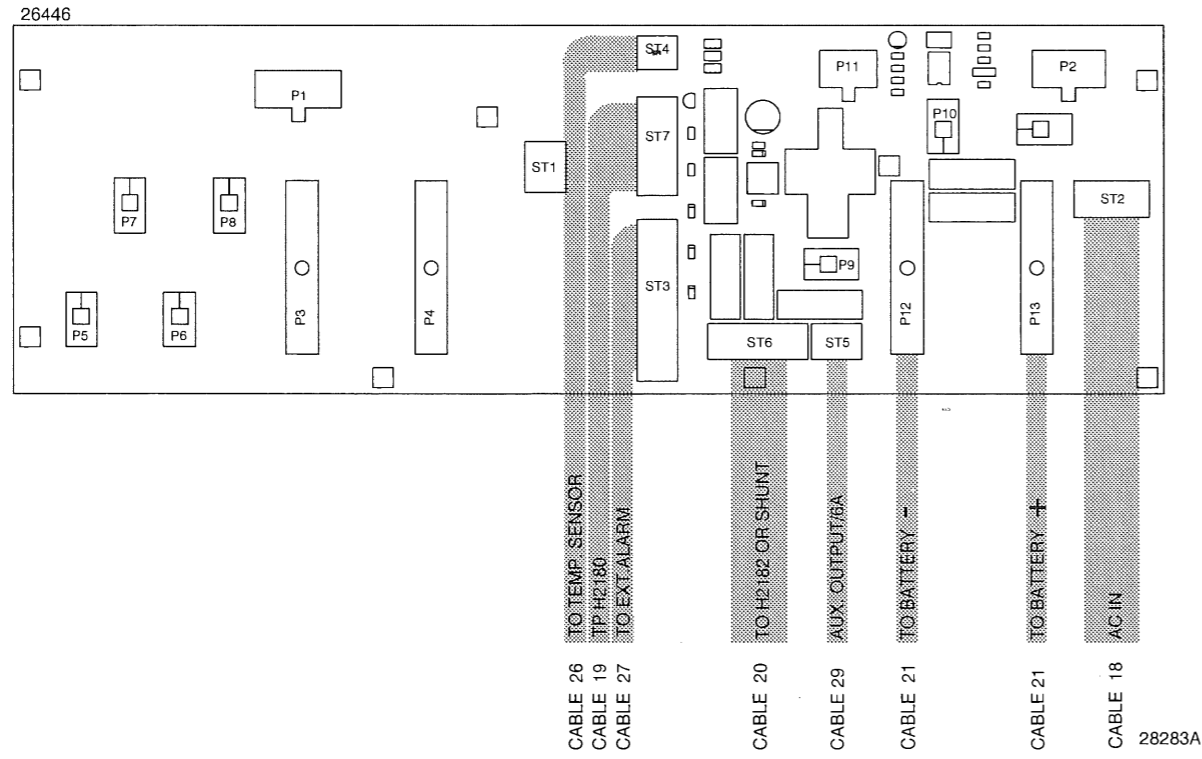

CONNECTION TO N2170 AND N2174

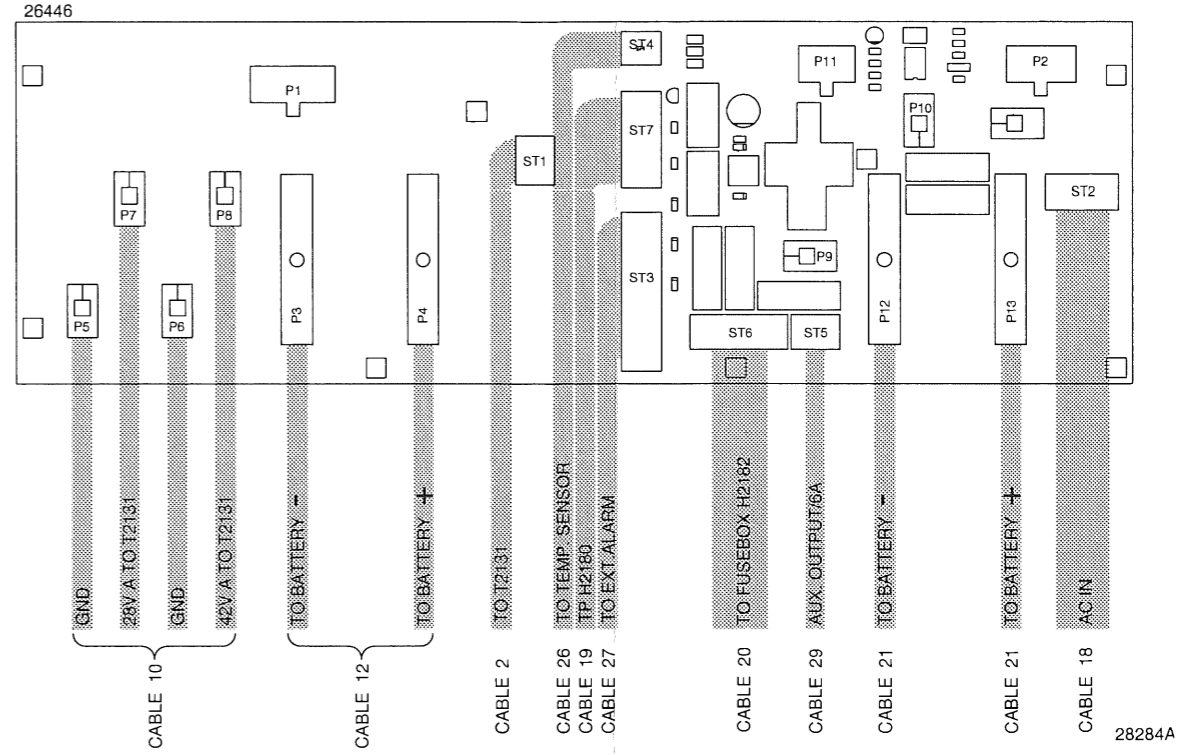

CONNECTION TO N2174 DUAL

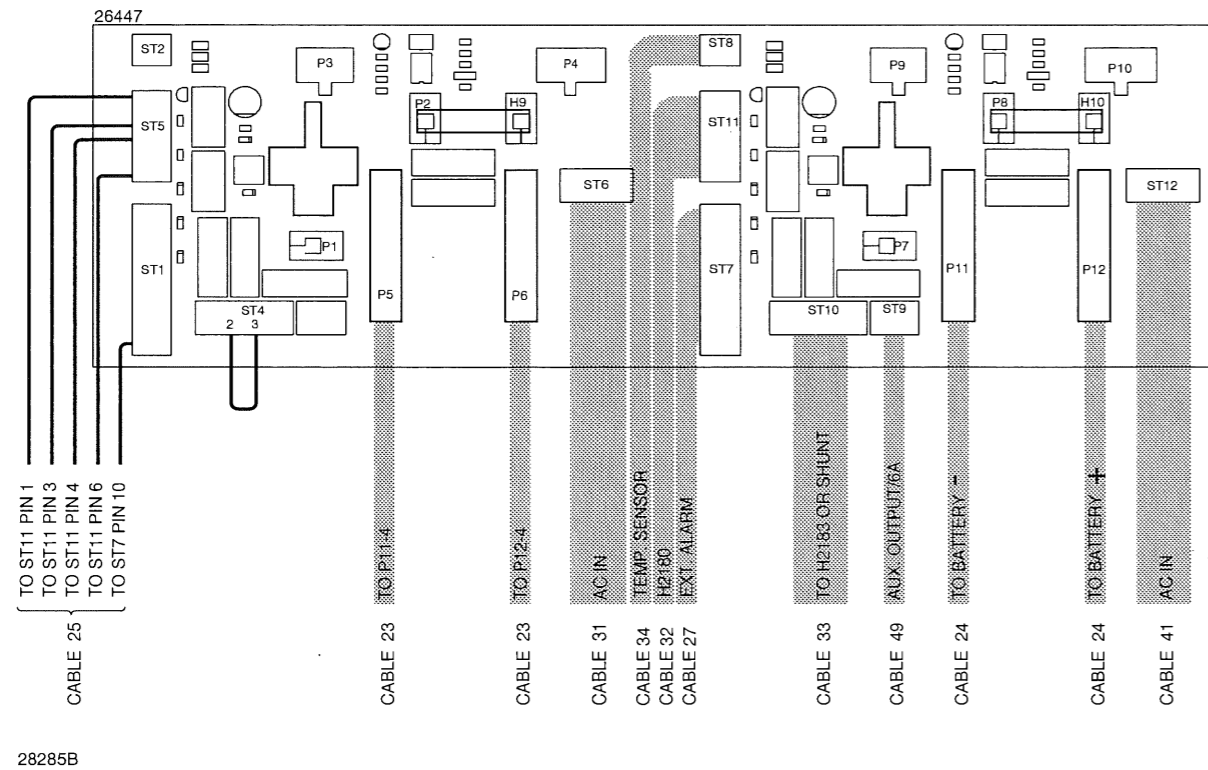

CONNECTION TO 2 X N2174

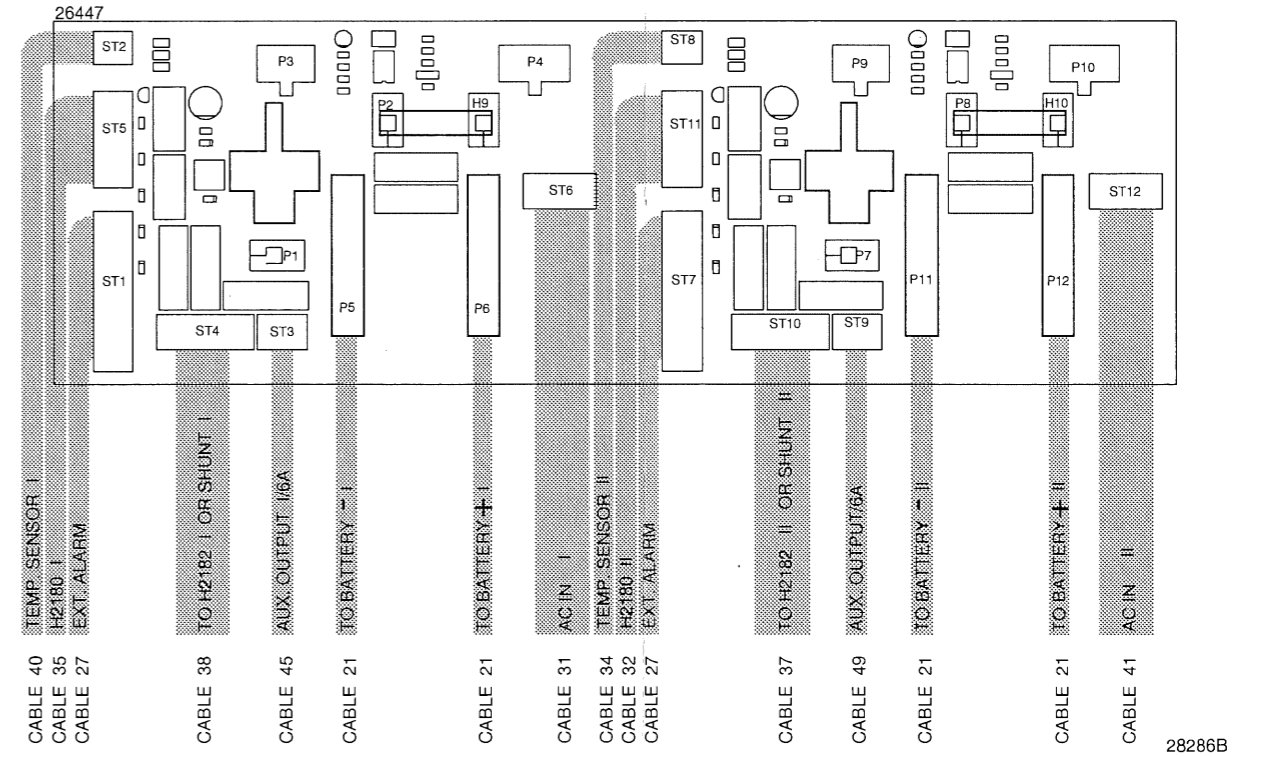

2.3 BATTERY REQUIREMENTS FOR GMDSS

6 HOURS REQUIREMENT:

The radio batteries must have sufficient capacity to supply the radio station for 6 hours (3 hours transmit and 3 hours standby).

When the battery is drained in 6 hours, instead of the normal 20 hours, you have add 20% to the capacity given by the manufacture.

The three hours transmit has to be in telex mode ARQ.

Equipment	Mode	Current	Battery capacity
T2131/DSC	transmit	30A	90Ah
T2131/DSC	standby	3A	9Ah
VHF/DSC	transmit	7A	21Ah
VHF/DSC	standby	.33A	1Ah
EMERGENCY LIGHT	on	1A	6Ah
GPS RECEIVER	on	1A	6Ah
TOTAL 6 HOURS			133Ah
+ 20 %			159.6Ah

If you chose to make a installation without AC power supply N2171. Then you must have a battery charger large enough to ensure, that you not will drain your batteries during transmission. That gives a charger requirement of 40 amp. The maximum allowable charge current is 10% of the battery capacity. When the charger can give 40 amps the battery capacity must be **400Ah**.

We recommend 400Ah battery capacity.

If you chose to make a installation with AC and DC power supply N2171/N2170. Then you must have a battery charger large enough to ensure, that you can charge your batteries, within 10 hours. That gives a charger requirement of 20 amp.

The maximum allowable charge current is 10% of the battery capacity.

We recommend 200Ah battery capacity.

1 HOUR REQUIREMENT:

The radio batteries must have sufficient capacity to supply the radio station for 1 hour (0.5 hours transmit and 0.5 hours standby).

When the battery is drained in 1 hour, instead of the 24 hours, you have add 50% to the capacity given by the manufacture.

The half hour transmit has to be in telex mode ARQ.

Equipment	Mode	Current	Battery capacity
T2131/DSC	transmit	30A	15Ah
T2131/DSC	standby	3A	1.5Ah
VHF/DSC	transmit	7A	3.5Ah
VHF/DSC	standby	.33A	.17Ah
EMERGENCY LIGHT	on	1A	1Ah
GPS RECEIVER	on	1A	1Ah
TOTAL 1 HOURS			22.7Ah
+ 50 %			33.26Ah

If you chose to make a installation without AC power supply N2171. Then you must have a battery charger large enough to ensure, that you not will drain your batteries during transmission. That gives a charger requirement of 40 amp.

The maximum allowable charge current is 10% of the battery capacity. When the charger can give 40 amps the battery capacity must be **400Ah**.

We recommend 400Ah battery capacity.

If you chose to make a installation with AC and DC power supply N2171/N2170. Then you must have a battery charger large enough to ensure, that you can charge your batteries within 10 hours. That gives a charger requirement of 4 amp.

The maximum allowable charge current is 10% of the battery capacity.

We recommend 90Ah battery capacity.

2.4 110/220V STRAPPING FOR T2131 - N2171 - N2174

T2131/35
TX CONTROL UNIT

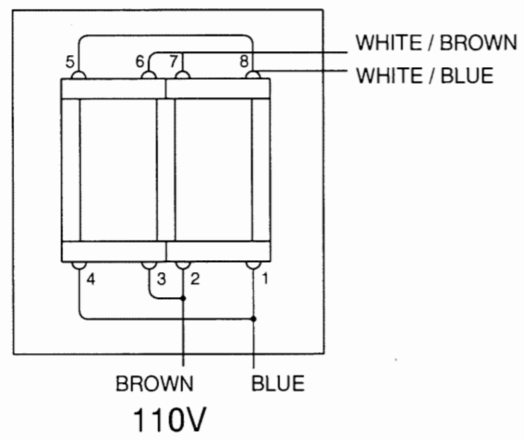
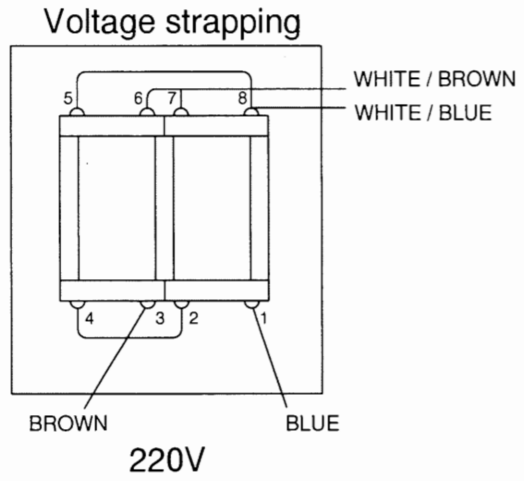

29327

N2171

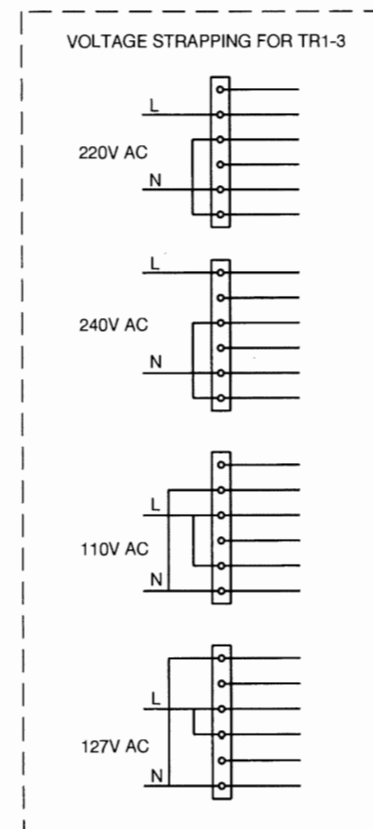
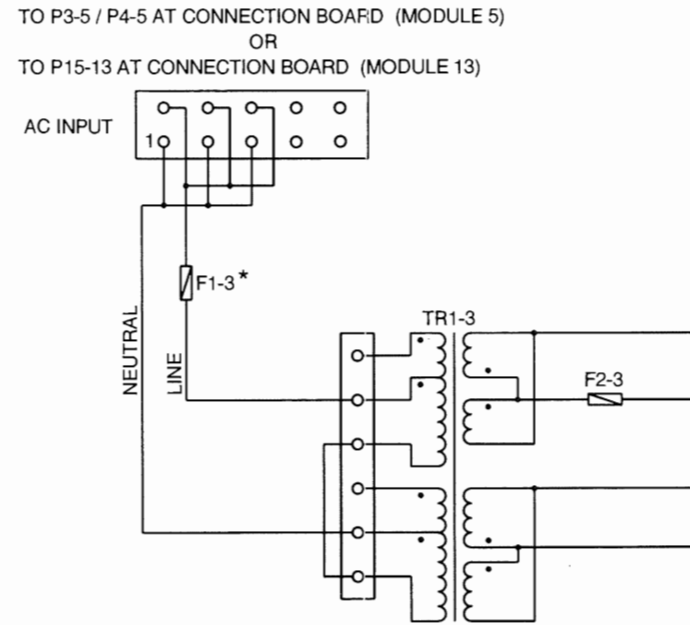

* NOTE: FOR AC INPUT OF 110V AC/127V AC THE FUSE F1-3 HAS TO BE CHANGED FROM 8A TO 15A S.P. NUMBER 45.630

29328

N2174

TO P2-3 AT CONNECTION BOARD (MODULE 3)
OR
TO P4-4 / P10-4 AT CONNECTION BOARD (MODULE 4)

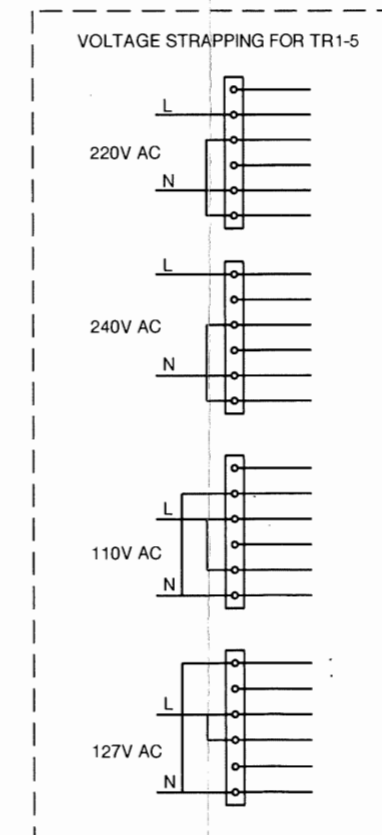
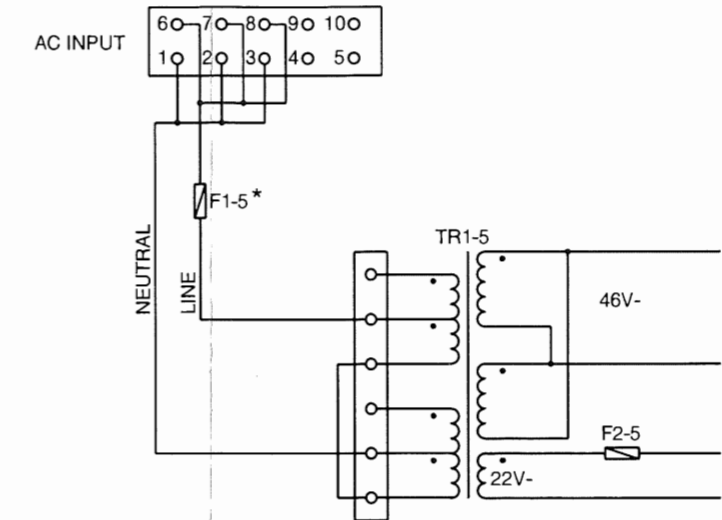

* NOTE: FOR INPUT VOLTAGES OF 110V AC / 127V AC THE FUSE F1-5 HAS TO BE CHANGED FROM 15A TO 25A (S.P. NUMBER 45.632)

29329

CONTENTS

3	SERVICE	
3.1	MAINTENANCE	3-1
3.2	ALIGNMENT INSTRUCTIONS	3-1
3.3	PROPOSAL FOR NECESSARY MEASURING INSTRUMENTS	3-1
3.4	TROUBLE SHOOTING	3-1
3.5	SYSTEM FUNCTION DESCRIPTION	3-7
3.6	PERFORMANCE CHECK	3-15
3.7	FUNCTION CHECK	3-17
3.8	SERVICE PROGRAMMES	3-18

3 SERVICE

3.1 MAINTENANCE

PREVENTIVE MAINTENANCE

If the HF SSB system has been installed properly the maintenance can, dependent on the environments and working hours, be reduced to a performance check at intervals, not exceeding 12 months. A complete performance check is enclosed in this manual, chapter 3.5. PERFORMANCE CHECK.

Inspection of the antenna, cables, and plugs for mechanical defects, salt deposits, corrosion, and any foreign bodies shall be done at regular intervals not exceeding 12 months.

Along with each HF SSB system test sheets are delivered in which all the measurements made in the test department of the factory, are listed. If the control mesurings made in the service workshop should not show the same values as those listed in the test sheet, the set must be adjusted as specified in the parts concerning the units in question.

3.2 ALIGNMENT INSTRUCTIONS

INTRODUCTION

The measuring values indicated in chapter 5. CIRCUIT DESCRIPTION AND SCHEMATIC DIAGRAMS are typical values and as indicated it will be necessary to use instruments in absolute conformity with the below list:

3.3 PROPOSAL FOR NECESSARY MEASURING INSTRUMENTS

Tone Generator type PM5107	PHILIPS
Electronic Multimeter type PM2505	PHILIPS
RF Directional Wattmeter model 43	BIRD
Oscilloscope type PM321	PHILIPS
Dummy load 50 ohm/600W	
Power supply 21-32V,	50A (600W transmitter)
	100A (1200W transmitter)

3.4 TROUBLE SHOOTING

In this section you will find guidelines which will enable you to find the faulty unit. The units are the following:

- Control Unit RE2100
- Power supply unit N2170/N2171
- Power amplifier unit
- TX-control unit
- Connection board

In order to help you finding the faulty unit we have built detectors into the transmitter. The RE2100 will show an error code in the display when a fault is detected. Furthermore we have built in some service programmes. How to select these service programmes please refer to chapter 3.8.

ERROR MESSAGES

The error messages are displayed in the upper part of the display in the RE2100. Table 1. indicates the possible faulty units. An asterisk in parenthesis (*) indicates the alternative unit where the error may also be found.

ERROR	RE2100	T2131	AT2112
70		*	*
73		(*)	*
75		(*)	*
76		*	
80		*	
81	*	(*)	
82	*	(*)	
83		*	
84		*	
85		(*)	
86		*	
87		*	
88		*	
90		*	
92		*	
95			

Table 1.

The error messages with numbers from 70 to 95 are generated by the TX-processor and mainly related to the T2131 and the AT2112. For the detailed error description please refer to the following table and the block diagram.

Error Code	Power Amplifier module 11	AC Power Supply	DC Power Supply	TX Control Unit	Connection Board module 13
20				*	(*)
70				*	(*)
73				(*)	(*)
75				(*)	(*)
78				*	
80	(*)			*	
81				(*)	*
82				(*)	
83	*	*	*	(*)	
85				(*)	(*)
86		*			
87	*			(*)	
91	*			(*)	

An asterisk in parenthesis (*) indicates the alternative unit where the error may also be found. For the detailed error description please refer to section 3.4.1. ERROR CODES.

3.4.1 ERROR CODES

ERROR MESSAGES, DESCRIPTION

The error messages displayed in the RE2100 display are described in the following technical description.

70. MOTOR CIRCUIT ERROR

An error is detected in the circuit controlling the tune motor MO1 in AT2112. The TX-processor has detected no 180° pulse from AT2112. Please refer to PART II chapter 3.3.8

73. HIGH SWR WHEN TUNING AT2112

It is not possible to tune the AT2112 to an SWR better than 2.5.

- Check the Antenna.
- Check the RF-signal path from the Power Amplifier Unit (11) in the T2131 to the antenna.
- Check the SWR detector on the Filter Switch (7). Please refer to PART II chapter 3.4.7.

75. HIGH SWR WHEN TRANSMITTING

This error may occur if the antenna has become bad since the latest up-tune on the frequency or has become bad during a transmit period.

SP 23-0 displays the latest SWR measured.

78. INTERNAL SWR TOO HIGH

The SWR in the internal dummy load used for the automatic power setting is too high. For frequencies lower than 20 MHz the SWR limit is 1.7. For frequencies above 20 MHz the SWR limit is 1.9.

Please refer to PART II chapter 3.4.7.

80. POWER OUT FAIL

The level of the Power out voltage is under a low limit measured in approx. 2 seconds at the output of the Filter Switch (7).

The error is probably in the T2131:

- Check the output of the power amplifier (11). Please refer to PART III chapter 3.6.
- Check the output of the Filter Switch (7). Please refer to PART II chapter 3.4.7.

81. POWER IN LOW

The level of the Power in voltage is low (<0.4volt), measured at the Microprocessor (8) P5 pin 1.

This error only occurs when the TX-Processor makes a drive setting.

The RF-input signal is probably missing.

- Check the RF connection between the RE2100 and the T2131.
- Check the RF output from RE2100. Please refer to the RE2100 manual chapter 3.6.
- Check the POWER IN detector at the Connection Board (13). Please refer to chapter 5.1.

82. POWER OUT HIGH

The level of the Power out voltage is high.

- Check the RF output from the RE2100. Please refer to the RE2100 manual chapter 3.6.
- The error may also occur if the T2131 has been improperly calibrated.
Please refer to chapter 3.7.1 calibration.

83. POWER AMPLIFIER

The level of the V_{forward} voltage is under a low limit measured in approx. 2 seconds at the filter switch (7).

- Check the power supply, please refer to PART V chapter 3.4, and PART VI chapter 3.4
- Check the Power Amplifier (11) Please refer to PART III chapter 3.6.
- Check the SWR detector on the filter switch module (7). Please refer to PART II chapter 3.4.7.

85. AC SUPPLY MISSING

The AC supply is under a low level (< 180 Volt).

The error is probably outside the T2131:

- Check the AC voltage level on the Connection Board (13). ST9 between Pin 2 and Pin 3 approx. 220 Volt AC. (190-242 volt)

Inside the T2131:

- Check the AC SENSE detector on module (9). Please refer to PART II chapter 3.3.9.

86. AC POWER SUPPLY UNIT DEFECT

The error is probably inside the AC POWER SUPPLY (N2171).

Note! This error code is only valid if the T2131 is installed with both AC and DC power supplies.

- Check the power supply, please refer to PART VI chapter 3.4

87. TRANSMITTER TEMPERATURE HIGH IN THE POWER AMPLIFIER

SP 21-0 displays the state of the temperature protection function. Please refer to the Service Programmes.

Ensure a free air flow into the T2131 chassis.

- Check that the blower in Power Amplifier is running and that a free air flows through this module.
- Check the idle current in the Power Amplifier (11). Please refer to PART II chapter 3.6.
- Check the temperature measuring circuit.
Please refer to PART II chapter 3.4.8.3 A/D CONVERTER.

91. TEMPERATURE SENSOR ERROR IN THE POWER AMPLIFIER

The temperature is measured to be very high or very low, indicating an error in the temperature measuring circuit. Please refer to PART II chapter 3.4.8.3 A/D CONVERTER/Temperature Measuring.

95. OPERATOR ERROR

The transmitter frequent is higher than 28.0 MHz, and is not allowed.

3.4.2 INTELLIGENT FAULT SYSTEM

The T2131 transmitter is designed with an intelligent fault system. This fault system secures a safe transmission if an error occurs in the AC power supply (PART VI) under stand by or transmission. If an error arise in the AC power supply, the transmission is only stopped in 400 msec., the time it takes to start the DC power supply. Therefore, it is possible to transmit voice or telex without being interrupted. The T2131 will after some time try to use the AC power supply again, in order to protect the ships radio batteries.

VARIATION IN AC SUPPLY VOLTAGE.

If the AC sensor detects a low AC Mains supply voltage, the power supplies are switched over from AC to DC. If the AC Mains supply voltage returns later, the TX-processor makes a new 'drive set' and the AC power supply is switched on again. 'error 85' is displayed in the RE2100.

FAULT IN POWER AMPLIFIERS.

If an error arises in the Power amplifier, there is no possibility to transmit, the power supply is switch off, and 'error 83' is displayed in the RE2100.

FAULT IN THE OUTPUT FILTER.

If an error arises in the output filter there is no possibility to transmit, the power supplies are switch off, and 'error 80' is displayed in the RE2100.

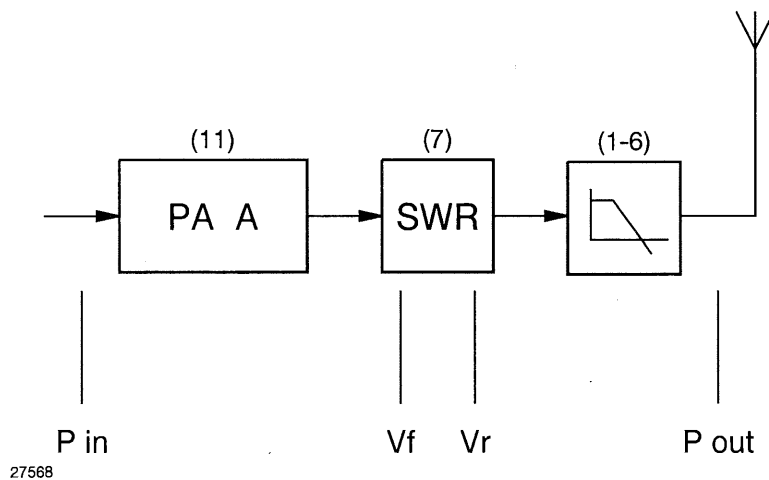

The measurements are executed in the following order Pin, Vf, Pout.

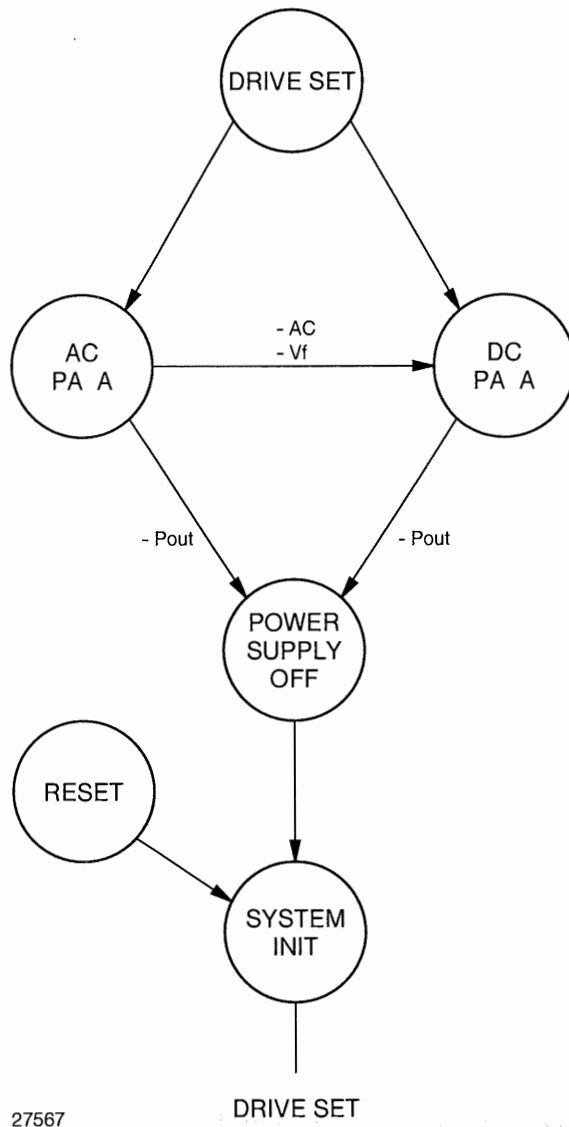

27567

DRIVE SET

This figure illustrate what happens if a fault occurs in the AC power supply.

EXAMPLE.

An T2131 is installed with AC and DC power supply (600W).

Under transmission.

The fuse blows in +42V A AC power supply. There is no signal on Vforv (Vf).

1. The +28V,+42V A AC power supply is switched off.
2. The +28V,+42V A DC power supply is switched on (600W).
3. 'error 86' is displayed in the RE2100 when the key is released

Under these circumstances when the +42V A AC power supply is defect, the intelligent fault system at first try the AC power supplies and then switch over to DC power supplies. This is done in order to protect the ships radio batteries.

Limits of voltage in the T2131.

1. Connect a 50 Ohm dummy load instead of the aerial.
2. Move the service strap, into the RE2100. When the service strap P03 in Processor module (5) is moved, the T2131 is set to service mode. Please refer to chapter 5.10 in the Service manual for RE2100.
The display will show 'SP- '
3. Those the trouble shooting service program SP-29
Key in 29 on the RE2100.
The Transmitter starts the power supplies, and the RE2100 deliver a 1600 kHz two-tone rf-signal to the transmitter.
4. Adjustment of the rf-level of the two-tones is done by using the keys <FREQ UP> and <FREQ DOWN> on the front of RE2100.
5. The rf-level must be 1650mV pp measured at the Coax cable on the connection Board (14) at ST1 pin 1.
6. Check all power voltage in the transmitter.

Meas ref. GND	AC voltage (volt pp)	Mess point	DC voltage (volt)	Mess point	Read out SP-xx	DC (volt) +/- xx %
Power in	1.65 Volt pp	ST1 pin 1 module 13	0.6-0.9 Volt	P3 pin 1 module 13	SP-22-1	+/- 20 %
Vforward	350-430 Volt pp	J4 module 7	5.8-8.0 Volt	P1 pin 7 module 7	SP-22-4	+/- 20 %
Vreverse			0.1-1.1 Volt	P1 pin 8 module 7	--	--
Power out	290-390 Volt pp	J3 module 7	2.2-3.4 Volt	P1 pin 9 module 7	SP-22-5	+/- 20 %

The service program SP-22-1 and SP-22-4 is only valid from the software version C1096F.

7. Move the service strap back to normal position.

3.5 SYSTEM FUNCTION DESCRIPTION

This section mainly describes the overall functions of the software in the T2131.

The main functions are described in sections, where section SP-BUS COMMUNICATION TO T2131 is a common section to be read in conjunction with the other.

In order to have the full understanding of the mode of operation of the T2131, section SYSTEM FUNCTION DESCRIPTION has to be read together with the chapter 5. CIRCUIT DESCRIPTION in PART II.

This section describes the following function.

3.5.1 SP-BUS COMMUNICATION TO T2131

The SP-bus is a time multiplexed serial data bus. The RE2100 is the master and the T2131 is one of several slaves. The T2131 is assigned a given slave address. RE2100 initiates and controls all communication to the T2131. This means that all activities performed in T2131 is controlled by the RE2100.

The T2131 may receive a number of commands according to the expected action in the T2131. When the T2131 has received a message it must replay immediately. The T2131 has four different options to answer the RE2100:

- A: The received command is understood and is executed.
- B: The received command is understood and T2131 is busy executing the command.
- C: The received command is understood and is executed.
The T2131 has information for the RE2100.
- D: A communication error is detected. The command is not executed.
The error can be a parity error or a message length error.

The answer options A, B and C may be followed by information related to the specific command. If the T2131 does not answer, the RE2100 is repeating the command a number of times. If the T2131 does still not answer, an error (Error 20) will occur in the display of the RE2100.

COMMANDS AND ANSWERS

In the following the commands to the T2131 and the answers from T2131 are described.

SYNCHRONIZE / STATUS AND ERROR CODE

This command/answer is used in two situations:

- When the power has been switched on at the RE2100, the RE2100 detects the existence of possible slaves.
- When the T2131 has detected an error, the T2131 has answered the previous message with the answer option (C). This results in a synchronized message from the RE2100.

RECEIVER FREQUENCY

Whenever the receiver frequency has been changed at the RE2100 the frequency is sent to the T2131. The T2131 ensures that a transformer is switched in at receiver frequencies below 4000 kHz and switched out at frequencies above 4000 kHz. If the aerial coupler is tuned properly on the same frequent as the receiving frequent, the aerial coupler relays are activated in order to have the correct impedance.

KEY

This command is sent continuously to the T2131 when the handset key is activated at the RE2100. The first time it is sent, the command is followed by the actual transmitter frequency and the selected mode (telex etc.) at the RE2100. The answer is option (A). The following commands are sent without associated data. There are two different answers depending on the state of the T2131. In both states the T2131 has the full control of the step attenuator placed in the Exciter Unit (4) in the RE2100.

- State one. Indicates that the T2131 and the AT2112 are N O T ready to transmit.
The answers consist of the answer option (B) associated with an absolute step.
The duration of this state is given by the duration of the automatic power setting and the tuning of the AT2112.
- State two. The T2131 and the AT2112 is ready to transmit.
The answers consist of the answer option (A) associated with an absolute step.
This state continues until the key is released and the "Stop" command is sent from the RE2100.

TUNE

This command is a subset of the "Key" command. Only state one is performed followed by the "Stop" command. The command is only sent from the RE2100 when the "TX" and "Tune" keys are activated.

Dummy Load Key

This command is equal to the "Key" command except for the RF output power. The RF output power is delivered to the AT2112 built in dummy load instead of the connected aerial.

DUMMY LOAD TUNE

This command is equal to the "Tune" command except for the RF output power. The RF output power is delivered to the AT2112 built in dummy load instead of the connected aerial.

STOP TUNE/KEY

This command always terminates the above mentioned 4 variants of "Tune" and "Key" commands. The answer is option (A). The command is sent from the RE2100 at one of the following events:

- When the handset key is released after a transmit period.
- When the T2131 is ready to transmit after the "TX" - "Tune" keys have been activated.
- When the "Enter/Stop" key is pressed while the Automatic Power setting or the tuning of the AT2112 takes place.

OPEN AERIAL

This command sets the relays in the AT2112 so that the aerial is disconnected from the HF SSB RE2100.

SERVICE

This command is always associated by a service subcommand. There are several service subcommands, each corresponding to a given Service Programme. The answer consists of option (A) or (B) followed by 5 ASCII characters which are displayed in the lower part of the display in the RE2100.

3.5.2 AUTOMATIC POWER SETTING

Motive for the Automatic Power Setting

The automatic setting of the power level is done in order always to have the maximum RF-level out of the Transmitter T2131 regardless of:

- Variations in the RF-level out of the RE2100 Exciter
- RF-loss due to long cables between the RE2100 and the T2131.
- Variations in the gain in the Power Amplifier from one to another.
- Variations in the gain in the Power Amplifier due to the frequency.
- Variations in the loss in the Output Filter module from one to another.
- Variations in the loss in the Output Filter module due to the frequency.

PRINCIPLES FOR THE AUTOMATIC POWER SETTING

The RF-level out of the RE2100 Exciter is increased step-wise until a predetermined maximum allowable Power out level of the Output Filter (1) is reached.

EVENTS FOR STARTING THE AUTOMATIC POWER SETTING

The automatic power setting is done because of one of the following events:

- The TX-frequency is changed and the key on the handset has been activated.
- The TX-tune key on the Keyboard is pushed.
- The time elapsed since latest transmission is more than approx. 30 secs.
- The AC supply is returned after a short or long period
- The PA- or power supply module is defective.

NECESSARY SIGNALS AND PARAMETERS

- Power out.
The RF-level is measured by a detector circuit on the Output Filter (7) and is mentioned as "P_out".

P_out is measured by the TX-processor (8) by use of an analog to digital converter.

- P_out maximum.
The predetermined maximum allowable P_out level is composed of a number of parameters. This composition of the maximum allowable P_out is described in a section below.
In the following it is assumed that the maximum allowable P_out has already been calculated.
The predetermined maximum allowable P_out level will in the following sections be mentioned as Po_max (Power out maximum).

- RF-level control.
A digitally controlled step attenuator with 64 steps, each step is approx. 0.3 dB, is placed in the Exciter Unit (4) in the RE2100.
During the automatic power setting the TX-processor (8) in the T2131 has the full control of the step attenuator via the SP-Bus and the Processor Module (5) in the RE2100.

FUNCTIONAL DESCRIPTION OF THE AUTOMATIC POWER SETTING

When the automatic power setting is about to start the step attenuator in the Exciter Unit (4) is preset to step 43 by the answer to the first "Tune" command. The automatic power setting may now take place in 2 or 3 states, depending on the initial measured P_{out} (step 43) related to the Po_{max}.

- State 1 is always executed as the first state.
- State 2 is executed when the RF-level has to be increased one or more steps.
- State 3 is always executed as the last state in the automatic power setting.

STATE 1

The P_{out} level measured by the TX-processor at step 43 is compared to 4 different levels:

- A minimum level.
If p_{out} is lower, then an error is generated. The p_{out} level is too low.
- Po_{max} - 0.6 dB.
If P_{out} is lower, then a number of steps is calculated to increase the RF-level out of the Exciter. The calculation is described below. The automatic power setting continues at state 2.
- Po_{max}.
If P_{out} is lower or equal to, then the step is increased with one. The automatic power setting continues at state 2.
- Po_{max} +0.3 dB.
If P_{out} is lower, then the automatic power setting continues at state 3.
- Else an error is generated. The P_{out} level is too high.

STEP CALCULATION

In order to reduce the time used for the automatic power setting the RF-level is increased a number of steps initially. The number of steps "n" is calculated in the following way:

$$\frac{Po_{max}}{P_{out}} = 10^{((A / 20)) * n}$$

Where A is the resolution in dB in the step attenuator. Theoretically should A = 0.3 dB/step. However, there is a certain compression in the amplifiers, etc. involved. Iterations have shown that A = 0.43 dB/step is suitable in order to reach the correct power level in an acceptable time without overshoot.

STATE 2

In this state the RF-level is increased one step at a time and compared to 2 different levels:

- If P_{out} is higher then the automatic power setting continues at state 3.
- The previously measured P_{out} +0.2 dB. If P_{out} is lower, then the automatic power setting continues at state 3.
Else state 2 is repeated.
This specific comparing to the previous P_{out} +0.2 dB is performed to ensure that the increasing of the P_{out} is stopped if there has been an increase less than 0.2 dB.
This may occur when the Power Amplifier (1) has begun compressing the signal. The compressing of the signal gives amplitude distortion and increase the intermodulation.

STATE 3

This state is executed when the P_{out} was measured to be one step too high. RF-level is reduced one step because the previous level was too high. Depending of the event which started the automatic power setting, the RF-level is reduced further. If an AT2112 is in the system, (jumper 5 is not inserted) P_{out} is reduced 20 steps further (approx. 6 dB) in order to protect the Power Amplifier (1) while tuning the AT2112.

CALCULATING POWER OUT MAXIMUM

Po_max is compound of 3 parameters:

- An addition (Po_cal) as a result of the Calibration.
The calibration procedure is described in section 3.8.1 " Calibration "
- A gain/loss (po_frq) related to the frequency.
- A reduction (po_mrp) of reduced power for frequency <4 MHz.

Po_max is found in the following way:

- $po_max1 = po_cal * po_frq$

IF the FREQUENT <4 MHz

THEN po_max = the lowest selected of po_max1 and po_mrp.

In the following the parameters are described separately.

po_cal

This factor is the result of the calibration of the T2131 in maximum power out at 1.6 MHz. The principles for the calibration of the T2131 is described below.

po_frq

This factor is to reduce the variations in the gain of the Power Amplifier (11) and the variations in the loss in the Output Filter (1).

The size may either be higher or lower than one approx. (0.8 - 1.2).

There are 6 different sizes which may be multiplied. One for each frequency range covered by the lowpass filters in the Output Filter Module (1). The size for the frequency range 1.6 - 2.599 MHz is always 1.00, because 1.6 MHz is used as a reference.

po_mrf (only used for frequency <4 MHz)

This is in fact not an addition. It is possible to reduce the RF PEP power out of the transmitter in some steps by use of Service Programmes.

When the power is not reduced the po_mdc has a value which is 600 Watt.

When the power is reduced, the po_mdc has a fixed value corresponding to the selected PEP power level (400W, 200W, 100W).

3.5.3 TUNING THE AT2112

The tuning may take place in 3 different procedures:

- Tune-up, where a tuning is done from basic data.
- Retune, where the tuning is done from data saved at the latest tune-up.
- No tune, which is done when there is no AT2112 in the system (jumper 5 is inserted).

TUNE-UP PROCEDURE

This is the basic tuning procedure for tuning the AT2112.

The conditions for an tune-up procedure are the following:

- "TX-TUNE" is entered on the keyboard on the RE2100.
- The frequency has not been tuned before. This means that there is no valid data in the EEPROM's for the specific 200 kHz band in which the frequency is situated.
- The Retune procedure did not work out. The Retune could not be done with the data saved in the EEPROM's. The measured Standing Wave Ratio (SWR) was too high, > 2.5.
The aerial conditions may have been changed since the latest Uptune of a frequency in the 200 kHz band concerned or the data saved in the EEPROM's are deleted by use of Service Programmes.

The uptuning may take place in up to 6 states. The states are sequentially executed until the uptuning has been accepted.

1. The relays in the AT2112 are set so that the RF signal is fed straight through the coupler. This means that no resonance (inductance, (L)) or load (capacitance, (C)) are active.
If the SWR (Standing Wave Ratio) is better than or equal to 1.7, the tuning of the aerial is accepted. A possible previously saved combination is deleted from the EEPROM's.
If Jumper 4 on the TX-processor (8) is inserted this "signal straight through" combination will NOT be tested.
2. A sequence of shifting the resonance and the load in a certain pattern is running through. For each frequency band (200 kHz) a number of combinations of fixed resonance values (L) and fixed load values (C) are switched in.
For every combination of a fixed resonance and a fixed load, the variable inductor is run through the working range.
Within the working range of the variable inductor the SWR is measured and compared continuously to certain limits.

The first combination always contains the highest value of the resonance (most L is in) and the lowest value of the load (least C is in).

The next combinations each contains an increasing value of the load (C) and the highest value of resonance (L).

When the highest value of load has been tested the next lower value of resonance is switched in and all the load values are tested again.

The variable inductor is activated by the tune motor M01. The motor may run at high speed or at low speed. In the following mentioned as "high tune speed" and "low tune speed".

With the tune speed high, the SWR is measured and continuously compared to the following limits, and different actions may take place:

$1.0 \leq \text{SWR} \leq 1.5$.

The actual combination of resonance and load is kept and the tune speed is changed to low. The variable inductor is running through its variation range again.

When the SWR limit again is passed, the tune motor is stopped immediately and the tuning is accepted. The found combination of resonance and load and the SWR limit is saved in the EEPROM's for a later Retune procedure.

$1.5 < \text{SWR} \leq 2.0$.

The actual combination of resonance and load is remembered by the processor in order to tune with the low speed later.

$2.0 < \text{SWR} \leq 2.5$.

The actual combination of resonance and load is remembered together with a flag, indicating that the SWR is in the range $2.0 < \text{SWR} \leq 2.5$ by the processor in order to tune with the low speed later.

3. If no combination could give an $\text{SWR} \leq 1.5$ the remembered combinations giving an $\text{SWR} \leq 2.0$ are tested at low tune speed. The SWR is measured and is compared to the following limits, and different actions take place:
 - $1.5 < \text{SWR} \leq 1.7$.
The tune motor is stopped immediately and the tuning is accepted.
The found combination of resonance and load and the SWR limit is saved in the EEPROM's for a later Retune procedure.

4. If no combination could give an $SWR \leq 1.7$ the remembered combinations giving an $SWR \leq 2.0$ are tested again at low tune speed. The SWR is measured and is now compared to the following limit:

$$1.7 < SWR \leq 2.0.$$

The tune motor is stopped immediately and the tuning is accepted.

The found combination of resonance and load and the SWR limit is saved in the EEPROM's for a later Retune procedure.

5. If no combination could give an $SWR \leq 2.0$ the remembered combinations giving an SWR in the range $2.0 < SWR \leq 2.5$ are tested at low tune speed. The SWR is measured and is compared to the following limit:

$$SWR \leq 2.5.$$

The tune motor is stopped immediately and the tuning is accepted.

6. If no combination could give an $SWR \leq 2.5$, the AT2112 relays are set to feed the RF-signal straight through the coupler and this is then accepted as a tune-up. When the transmitter is keyed the RF-power is reduced accordingly to the actual SWR.

RETUNE PROCEDURE

This is the tune procedure normally used. The conditions for a Retune procedure are the following:

- A frequency within the same 200 kHz band has been tuned before to an $SWR \leq 2.0$. This means that valid data are read out of the EEPROM's and the aerial conditions have not changed essentially.

The data saved in the EEPROM's for a Retune is divided into 132 elements. Each element equals a frequency band covering 200 kHz. For each 200 kHz band a relay combination and a code for the tuned SWR are saved.

The principles for a Retune procedure are described in the following. Data concerning the actual 200 kHz band is read out of the EEPROM's and validated. If the code for the SWR is not acceptable, a tune-up procedure is started immediately. If the code for the SWR is valid then the codes for the SWR and the relays are converted. The specific relays are activated.

With the tune speed low the SWR is measured and compared continuously to the limit which is read out from the EEPROM's. The SWR limit is 1.5 or 1.7 or 2.0. The Retune procedure will then always try to tune to the same SWR limit as the Uptune procedure. However, if this is not possible the Retune will try to tune to the next higher limit. If not it is possible to tune to an $SWR \leq 2.0$ the Uptune procedure is started immediately.

NOTUNE PROCEDURE

This procedure is run only when there is no AT2112 connected to the T2131. In fact the jumper 5 on the TX-processor (8) must be inserted.

The only purpose for this routine is to measure the SWR and if $SWR > 2.0$ inform the RE2100 and the user

3.5.4 TRANSMIT SUPERVISING

The motives for the supervising are as follows:

- Protection of the Transmitter T2131 against high SWR (bad antenna conditions).
- Protection of the power transistors in Power Amplifier (11) against damage caused by high temperature.
- Ensure that the transmitter T2131 always delivers maximum RF-power with a minimum of intermodulation.

When the Transmitter T2131 is keyed certain parameters are watched by the TX-processor (8) and action is taken if the change of the parameters is essential. The following parameters are watched:

- SWR, Standing Wave Ratio
- Temperature in the Power Amplifier (11)
- AC supply to the RE2100/T2131 system

In general causes a change of any of the watched parameters is a control of the RF-level input to the Power Amplifier. While the transmitter is keyed the TX-processor has the full control of the digitally controlled step attenuator in the Exciter Unit (4) in the RE2100 via the SP-Bus and processor Unit (5) in the RE2100. Each of the watched parameters results in a number of steps. The steps are simply added to the step found when the Automatic Power Setting was performed.

$$\text{act_step} = \text{APS_step} + n1 + n2 + n3$$

Where:

act_step = Actual step for the attenuator
 APS_step = The step found at the Automatic Power Setting.

n1 = Deviation step related to SWR
 n2 = Deviation step related to Temperature
 n3 = Deviation step related to DC supply

The subsections below describe each of the parameters watched.

SWR WATCHING

When the T2131 is transmitting, the SWR is continuously watched. This means in terms that the TX-processor (8) measures the Rho approx. 3100 times per second.

NOTE: Rho and SWR are two expressions describing the same physics.

$$\text{Rho} = \frac{\text{SWR} - 1}{\text{SWR} + 1} \quad \text{SWR} = \frac{1 + \text{Rho}}{1 - \text{Rho}}$$

The measured Rho is compared to two limits.

If $\text{SWR} > 2.0$ ($\text{Rho} > 0.333$) then a calculation takes place. The result of the calculation gives a number of 0.3 dB steps that the RF-signal has to be reduced with. The number of steps n1, is given by:

$$n1 = \frac{(\text{Rho} - 0.333) * 18}{0.3}$$

(n1 can not be negative or higher than 30 (10dB)).

If $\text{SWR} > 5.0$ then the error message "Bad SWR" is enervated.

The operator is informed with an error 75 in Rx display, when the key is released.

TEMPERATURE WATCHING

The temperature at the power transistors in the Power Amplifier (11) is measured 5 times per second. The measured temperature is compared to two limits. If the temperature is above 98° Celsius a calculation takes place. The result of the calculation gives a number of 0.3 dB steps that the rf-signal has to be reduced with. The number of steps n2, is given by:

$$n2 = \frac{\text{Measured temperature} - 98^\circ}{2}$$

(n2 can not be negative.)

This means that a temperature increase of 20° reduces the RF power approx. 3 dB.

If the temperature is above 118° Celsius the Power Amplifier (11) is blocked and the RF-power is further reduced approx. 60 dB, an error message is generated, and when the key is released the operator is informed. When the temperature has fallen to 108° Celsius the Power Amplifier (11) is opened again.

AC SUPPLY MISSING

If the voltage of the AC supply is falling under a low level the DC power supply is switched on, an error message is generated and when the key is released the operator is informed.

3.5.5 CALIBRATION OF THE T2131

In practice the calibration is done by use of a Service Programme. Please refer to the Service Programmes. In the following the calibration is described functionally.

MOTIVE FOR THE CALIBRATION

The calibration is done in order to eliminate tolerances in specific components related to the measuring of the Power_out voltage.

PRINCIPLES FOR THE CALIBRATION

The principle for the calibration is as follows.

The RF-power (1.6 MHz) is increased until a specific distortion is reached. The Power_out voltage is measured and stored as the Power_out_calibration voltage.

3.6 PERFORMANCE CHECK

The performance check is a test, which will enable you to determine if the T2131 is working in accordance with the factory specifications. If you need to test the individual units please refer to the performance check in that part which deals with the unit in question.

A performance check is intended to be used as a check after repair and before reinstallation of the equipment.

3.6.1 CHECK OF POWER SUPPLY N2170 OR N2171.

Select service programme SP 34-1 (N2171) or SP 34-3 (N2170). Check the +28V on the connectionboard (13), it must be 28V +/-2V, and check the +42V on the connection board (13), it must be 42V +/-4V.

3.6.2 CHECK OF OUTPUT POWER.

To check the output power you meet to connect a 50 ohm dummyload to the transmitter output on the connection board (13) ST3, and connect a oscilloscope across the output.

Select a frequency near to 2000 Khz.

Press the handset key, wait until the tune indicator in the display of RE2100 extinguish, then whistle in the microphone, and while whistling release the handset key.

Select service programme:

SP 22-0 Note the reading.

SP 22-1 the reading must be 3+/-1.

SP 22-5 the reading must be equal to the reading in SP 22-0 +/-0.7.

SP 22-4 the reading must be 7+/-1.

SP 23-1 the reading must be <1.4

SP 23-0 the reading must be <1.4

Speak into the microtelephone and check on the oscilloscope that the signal not is distort.

Repeat the above test on frequencies near to 6200 kHz, 12400 kHz and 22000 kHz.

Check the output power on a frequency near to 8200 kHz.

Connect the power meter to the output of the transmitter. Whistle into the microphone, and check the power reading on the power meter it must be 600W +/-100W.

3.6.3 CHECK OF CONTROL SIGNALS TO THE AERIAL COUPLER AT2112.

Select service programme and check the voltage in accordance with the table below.

Service programme	ST5 pin no.	voltage
30-1	1	28
30-2	2	28
30-3	3	28
30-4	4	28
30-5	5	28
30-6	6	28
30-7	7	28
30-8	8	28
30-9	9	28
31-0	10	28
31-1	11	28
31-2	12	28
31-3	13	28
31-4	14	28
32-2	15	18

3.6.4 CHECK OF AUDIO OUTPUT POWER.

Connect a oscilloscope across the loudspeaker terminal on the connection board (13).

Tune the receiver to a strong signal, turn the volume to a peak to peak voltage of 15v, with this output must the signal be undestored.

3.6.5 CHECK OF MUTE IN AND OUT.

Connect a ohmmeter from ST12 pin 1 to pin 2. Key the transmitter and check that RE 1 make contact (0 ohm).

Tune the receiver to a station. Then connect the 18V from ST12 pin 3 to pin 4, and check that the receiver is muted.

3.6.6 CHECK OF 0 DBM OUT.

Tune the receiver to a station. Check that the voltage from ST8 pin 3 to pin 4 is approx. 770mV.

3.6.7 CHECK OF AUX AF IN TX, TX KEY AND HT ON.

Select telex mode. Connect a AF generator from ST8 pin 1 to pin 2, and adjust the level to 770 mV. connect ST7 pin 6 and 8 to ground, and ST7 pin 7 and 9 to ST7 pin 2 (+18V). Check that there is power out of the transmitter.

3.7 FUNCTION CHECK

The function check is a quick check, which has to be carried out when the transmitter has been installed.

Select a frequency in the band 1600 kHz - 1799 kHz, or as low as possible. Then press <TX> <TUNE>, check that the tune lamp lights up. When the tune lamp extinguish, there should not be any error code in the display, if there is a error code see chapter 3.4.

Press the handset key and whistle into the microtelephone. While whistling release the handset key.

SELECTION OF SERVICE PROGRAMME

Press <1> and <0> simultaneously, the display will now show "SP-".

POWER IN CHECK

Then press <2><2><1><ENT> the display must show 3.0 +/-1, if not see chapter 3.4.

V_{FORW} CHECK

Then press <2><2><4><ENT> the display must show 7 +/-1, if not see chapter 3.4.

POWER OUT CHECK

Then press <2><2><5><ENT> the display must show 3.8 +/-0.7, if not see chapter 3.4.

SWR CHECK AFTER TUNING

Then press <2><3><1><ENT> the display must show 1.7, if not see chapter 3.4.

SWR CHECK AFTER TRANSMITTING

Then press <2><3><0><ENT> the display must show 1.7, if not see chapter 3.4.

ATTENUATOR STEP IN RE2100 CHECK

Then press <2><6><1><ENT> the display must show 5 to 25, if not see chapter 3.4.

END OF SERVICE PROGRAMME

Press <TUNE>, the display will now return to normal format.

To check if the aerial coupler will work on all frequencies with the aerial in question do as decrised below. Select a frequency in each band in accordance with the table below, if the frequency not is permitted for your application then you just select as many bands as possible. Then press <TX><TUNE>.

If a error code occur see chapter 3.4. The tune sequence might take up to 2 minutes.

BAND 0.	2182 kHz
BAND 1.	1600 - 1799 kHz
BAND 2.	1800 - 1999 kHz
BAND 3.	2000 - 2199 kHz
BAND 4.	2200 - 2399 kHz
BAND 5.	2400 - 2599 kHz
BAND 6.	2600 - 2799 kHz
BAND 7.	2800 - 2999 kHz
BAND 8.	3000 - 3099 kHz
BAND 9.	3100 - 3399 kHz
BAND 10.	3400 - 3699 kHz
BAND 11.	3700 - 3999 kHz
BAND 12.	4000 - 4299 kHz
BAND 13.	4300 - 4599 kHz
BAND 14.	4600 - 4999 kHz
BAND 15.	5000 - 5499 kHz

BAND 16.	5500 - 5999 kHz
BAND 17.	6000 - 6399 kHz
BAND 18.	6400 - 6999 kHz
BAND 19.	7000 - 7599 kHz
BAND 20.	7600 - 7999 kHz
BAND 21.	8000 - 8499 kHz
BAND 22.	8500 - 12299 kHz
BAND 23.	12300 - 12699 kHz
BAND 24.	12700 - 16399 kHz
BAND 25.	16400 - 16890 kHz
BAND 26.	16900 - 21999 kHz
BAND 27.	22000 - 22399 kHz
BAND 28.	22400 - 24999 kHz
BAND 29.	25000 - 25199 kHz
BAND 30.	25200 - 28000 kHz

Finally you make a call to a coast station and get a report from that station.
The function test are now completed.

3.8 SERVICE PROGRAMMES

It is in the following assumed, that the Service Programme Jumper is inserted in the RE2100.
In General: If the RE2100 displays 'Err.0' in a Service Programme the selected SP does not exist.

Example:

Operator:	Key:	20-7 <ENT>
RE2100:	Displays:	'SP-20-7 ' ' Err.0'

Legend: Err.0 = The entered service programme does not exist.

3.8.1 SERVICE PROGRAMMES IN T2131

TEMPERATURE

SP-21-0 Display the state of the temperature protection.

Example:

Operator:	Key:	21-0 <ENT>
RE2100:	Displays:	'SP-21-0 ' ' 00.1'

Legend:

- 00.0 There has been no reduction of Power_out due to high temperature
- 00.1 There has been a reduction of rf-power due to high temperature in the POWER AMPLIFIER
- 00.2 The POWER AMPLIFIER has been blocked due to very high temperature.
- 00.3 There is an error in the temperature sensor

SP-21-1 Display the actual temperature in the Power Amplifier in ADC temp.

Example:
 Operator: Key: 21-1 <ENT>
 RE2100: Displays: 'SP-21-1'
 ' 15.8'

Legend: The 15.8 must be changed to an actual temperature. Temperature = app. 65°C

SP-21-3 Display the latest measured temperature in the Power Amplifier.
 The temperature is only valid after the transmitter has been keyed.

Example:
 Operator: Key: 21-3 <ENT>
 RE2100: Displays: 'SP-21-3'
 ' 19.6'

Legend: The 19.6 must be changed to an actual temperature. Temperature = app. 98°C

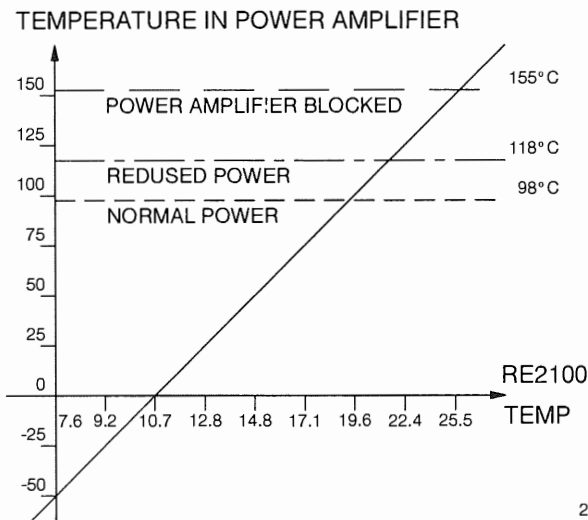

27576

Function between the ADC temp and the real temperature.

POWER IN, VFORWARD AND POWER OUT

SP-22-0 Display the latest Power_out MAX voltage.
 The Voltage is only valid after the transmitter has been keyed, and the "Drive set" is accpeted.

Example:
 Operator: Key: 22-0 <ENT>
 RE2100: Displays: 'SP-22-0'
 ' 4.0'

Legend: Measured in Volt.

SP-22-1 Display the latest measured Power_in voltage.
 Measured at P5 pin 1 on the Microprocessor module (8).
 The Voltage is only valid after the transmitter has been keyed.

Example:
 Operator: Key: 22-1 <ENT>
 RE2100: Displays: 'SP-22-1'
 ' 1.2'

Legend: Measured in Volt.

SP-22-4 Display the latest measured Vforward voltage.
 Measured at P4 pin 7 on the Microprocessor module (8).
 The Voltage is only valid after the transmitter has been keyed.

Example:

Operator: Key: 22-4 <ENT>
 RE2100: Displays: 'SP-22-5'
 ' 7.0'

Legend: Measured in Volt.

SP-22-5 Display the latest measured POWER_OUT voltage.
 Measured at P4 pin 9 on the Microprocessor module (8).
 The Voltage is only valid after the transmitter has been keyed.

Example:

Operator: Key: 22-5 <ENT>
 RE2100: Displays: 'SP-22-5'
 ' 4.2'

Legend: Measured in Volt.

SWR

SP-23-0 Display the latest measured SWR.

Example:

Operator: Key: 23-0 <ENT>
 RE2100: Displays: 'SP-23-0 '
 ' 1.6'

SP-23-1 Display the measured SWR when the tuning was finished.

Example:

Operator: Key: 23-1 <ENT>
 RE2100: Displays: 'SP-23-1 '
 ' 1.7'

EEPROM

SP-24-0 Test the EEPROM's for write and read.

Example:

Operator: Key: 24-0 <ENT>
 RE2100: Displays: 'SP-24-0 '

RE2100: Displays: 'SP-24-0 '
 ' A. '

Legend: A. = No Errors found
 Err.1 = Error found in U8.
 Err.2 = Error found in U9.

NOTE: The duration of the test is approximately 8 seconds.

SP-24-1 Delete all stored Retune Data from the EEPROM's.

Example:

Operator: Key: 24-1 <ENT>
 RE2100: Displays: 'SP-24-1 '

RE2100: Displays: 'SP-24-1 '
 ' A. '

Legend: A. = Deleting finished.

Initialize EEPROM's from scratch.
 Stores standard data in the eeprom

SP-24-2

Example:

Operator: Key: 24-2<ENT>
 RE2100: Displays: 'SP-24-2 '

RE2100: Displays: 'SP-24-2 '
 ' A. '

Legend: A. = Initialize finished.

Note: The T2131 must be turned off and on after the execution of this Service Programme.
The T2131 M U S T be Calibrated after this Service Programme.

CALIBRATION**SP-25** Calibrate the T2131.

Example:

Operator: Connect a oscilloscope across the internal dummy load R31 to R38
 see PART II page 5-2.

Operator: Key: 25
 RE2100: Displays: 'SP-25-0 '
 ' CAL. '

RE2100: Delivers a two-tone rf-signal (Same as tune tones). Tx-frequency: 1600.0 KHz.

T2131: Opens and closes for the two-tone rf-signal. Open in 1 seconds and closed in 4 seconds.

Operator: Adjust the voltage across the dummy load to $400V_{p-p}$ by means of the arrow keys on RE2100.

Note: The signal must be undistorted (no flat topping), If the signal is distorted there is something wrong with either the oscilloscope, the power amplifier or the dummy load. If the drive level are adjusted to high it will course damage on the power amplifier. It is very important that the oscilloscope you use is correct adjusted and are able to measure on a two tone signal.

If you don't have a good oscilloscope available then you can do following emergency procedure (only for software version C1096I or higher):

Select SP-24-2-ENT then switch off and on again and do nothing else. This will give you a little less output power but you can be sure that nothing will be damaged due to too high drive level.

Operator: Key: 1
 RE2100: Displays: 'SP-25-1'
 ' A. '

Legend: A. = Accepted. The T2131 is calibrated.
 Err.1 = POWER OUT Voltage high. See the description of Error Message 82
 Err.2 = POWER OUT Voltage low. See the description of Error Message 81
 Err.3 = Bad SWR in the internal dummy load.
 Note: If any 'Err.' comes up the T2131 is N O T calibrated.

Note: **After calibration it is necessary to switch off the power on the RE2100.**

Unintentional call of SP-25

If the operator unintentionally has keyed '25' it is possible to leave Service Programme 25 without calibrating the T2131 in the following way:

Operator: Key: <ENT> or <TUNE>

SP-25 may also be left by switching off the power on the RE2100.

STEP ATTENUATOR

SP-26-0 Display the Maximal step of the Step attenuator in the RE2100 Exciter.

Example:
 Operator: Key: 26-0 <ENT>
 RE2100: Displays: 'SP-26-0'
 ' 14. '

SP-26-1 Display the Actual step of the Step attenuator in the RE2100 Exciter.

Example:
 Operator: Key: 26-1 <ENT>
 RE2100: Displays: 'SP-26-1'
 ' 18. '

SOFTWARE VERSION

SP-27-0 Display the Version and the Release of the software in the Tx-processor(8) in T2131.

Example:
 Operator: Key: 27-0 <ENT>
 RE2100: Displays: 'SP-27-0 '
 ' 1096.A'

Legend: '1096A' is S. P. Radio's identification of the version of the software. On the label on the EPROM is written: C1096A

' ' = 1. release
 'A' = 2. release
 'B' = 3. release
 etc.

TROUBLE SHOOTING

SP-29 Trouble shooting service programme.

Example:

Operator: Key: 29
 RE2100: Displays: 'SP-29-0 '
 ' SE. '

RE2100: Delivers a two-tone rf-signal continuously (Same as tune tones).

Tx-frequency: 1600.0 KHz

T2131: The accordingly Low Pass filter is switched in and the transmitter is keyed. It is advisable to connect a 50 Ohm dummy load instead of the aerial coupler.

Operator: May now trouble shoot the transmitter without being disturbed by error messages etc. Adjustment of the rf-level of the two-tones is done by using the keys <FREQ UP> and <FREQ DOWN> on the front of RE2100.

When the trouble shooting is finished:

Operator: Key: <ENT>
 RE2100: Displays: 'SP- '

ADJUSTMENT

SP-33 Adjustment of the bias current in the power transistors in the Power Amplifier.

Example:

Operator: Key: 33
 RE2100: Displays: 'SP-33-0 '
 ' SE. '

T2131: The transmitter is keyed. There are no rf-signals applied to the Power Amplifier.

Operator: May now adjust the bias current in accordance to the adjustment procedure.

When the adjustment is finished:

Operator: Key: <ENT>
 RE2100: Displays: 'SP- '

POWER SUPPLIES

SP-34-X Activates both the 28V and 42V power supplies in AC or DC, and releases any other.

Operator: Key: 34-1 <ENT>
 RE2100: Displays: 'SP-34-1 '
 ' A. '

Power supply	SP-34-[1-8] <ENT>	Displays
(A) AC	34-1	'SP-34-1' ' A.'
(A) DC	34-3	'SP-34-3' ' A.'

Release all Power Supplies:

Operator: Key: 34-0 <ENT>
 RE2100: Displays: 'SP-34-0 '
 ' A. '

ACTUAL STATUS

SP-35-0 Display the actual status of the T2131.

Operator: Key: 35-0 <ENT>
 RE2100: Display 'SP-35-0 '
 ' 0.1 '

Legend: 0.0 It is NOT possible to transmit, all power supplies are released.

0.1 Power Amplifier A is install and is working. AC supply.

0.5 Power Amplifier A is install and is working. DC supply.

MAX RF POWER AT FREQUENT < 4 M Hz

SP-37-X Set MAX Rf-Power for frequents < 4 Mhz

Power Levels: 0 = Normal, 600W
 1 = 1200W
 2 = 400W
 3 = 200W

Example:

Operator: Key: 37-[0-3]<ENT>
 RE2100: Displays: 'SP-37-[0-3] '

RE2100: Displays: 'SP-37-1 '
 ' 400. '

Legend: 400. = Set to 400 W.

FILTER RELAYS

SP-38-X OUTPUT FILTER relay drivers.

Activate each of the six Filter Drivers one bye one, and release any other.

A. Enter SP-38-[1-6]

Driver	Frequency range	SP-38-X <ENT>	U	pin
Filter 1	1.6 - 2.399 Mhz	38-1	21	14
Filter 2	2.4 - 3.899 Mhz	38-2	21	15
Filter 3	3.9 - 6.399 Mhz	38-3	21	13
Filter 4	6.4 - 10.399 Mhz	38-4	21	11
Filter 5	10.4 - 16.899 Mhz	38-5	14	12
Filter 6	16.9 - 28.000 Mhz	38-6	21	10
DRIVE Control		38-7	21	16
RX/TX Control		38-8	21	12

B. Connect the voltmeter to the specific pin. Voltage is < 1.1 Volt.

C. Enter SP-38-0 <ENT>

POWER Limits

SP-39-4 Display the Vforward voltage that shall be exceed, unless the Power amplifier is NOT OK.
The Voltage is only valid after the transmitter has been keyed or tuned.

Example:
Operator: Key: 39-4 <ENT>
RE2100: Displays: 'SP-39-4'
' 3.4'
Legend: Measured in Volt.

SP-39-5 Display the Power out voltage that shall be exceed, unless the Filter module is NOT OK.
The Voltage is only valid after the transmitter has been keyed or tuned.

Example:
Operator: Key: 39-5 <ENT>
RE2100: Displays: 'SP-39-5'
' 1.5'
Legend: Measured in Volt.

SP-39-0, SP-39-1 and SP-39-2 are used for internal test.

3.8.2 SERVICE PROGRAMMES RELATED TO AT2112**AT2112 RELAYS**

SP-30-X Activate AT2112 Relays, Control 1-9 one by one, and release any relay.

Example:
Operator: Key: 30 - [0-9] <ENT>
RE2100: Displays: 'SP-30-[0-9] '
' A. '
Legend: 0 = No relays activated
1 - 9 = Relays 1 - 9 activated
A. = Accepted.

The T2131 Activates the entered AT2112 Relay no., other relays are released.

SP-31-X Activate AT2112 Relays, Control (10-11), AREAL RELAY (12), RX/TX (13) and RX < 4 Mhz (14) one by one.

Example:
Operator: Key: 31 - [0-4] <ENT>
RE2100: Displays: 'SP-31-[0-4] '
' A. '
Legend: 0 - 1 = Relays 10 - 11 activated
2 = Antenne Relay TX
3 = RX / TX Relay
4 = RX < 4 MHz
A. = Accepted.

If The AT2112 is NOT in the system (Jumper 5 is inserted in the Tx-processor) the following is displayed:

RE2100: Displays: SP-31-X'
' Err.1'

Release all areal relays.

Enter: SP-30-0<ENT>

MOTOR**SP-32-1** Sets supply on the AT2112 'MOTOR' line, (low speed).

Example:

Operator: Key: 32 - 1 <ENT>
RE2100: Displays: 'SP-32-1 '
' A. '

SP-32-2 Sets supply on the AT2112 'MOTOR' line, (high speed).

Example:

Operator: Key: 32 - 2 <ENT>
RE2100: Displays: 'SP-32-2 '
' A. '

Stop motor

Operator: Key: 32 - 0 <ENT>
RE2100: Displays: 'SP-32-0 '
' A. '

CONTENTS

4	MECHANICAL DESCRIPTION	4-1
4.1	MECHANICAL ASSEMBLING / DISASSEMBLING AND UNITS LOCATION	4-1

4.1. MECHANICAL ASSEMBLING / DISASSEMBLING AND UNITS LOCATION

28225.PM4

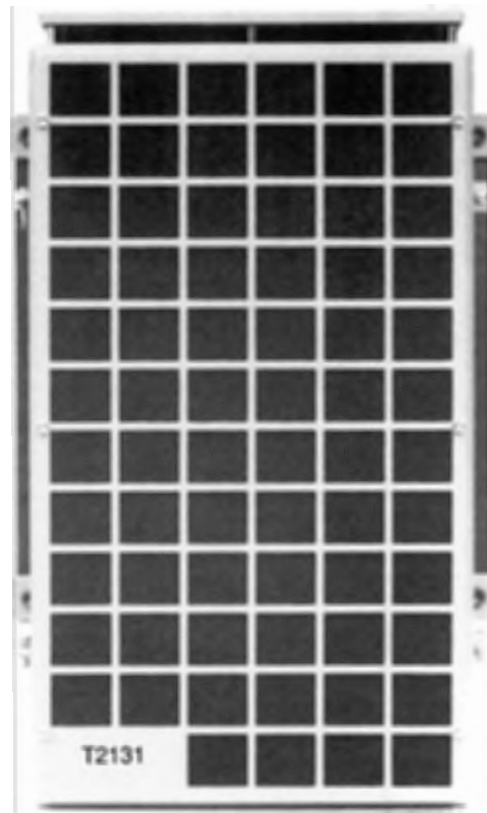

501117

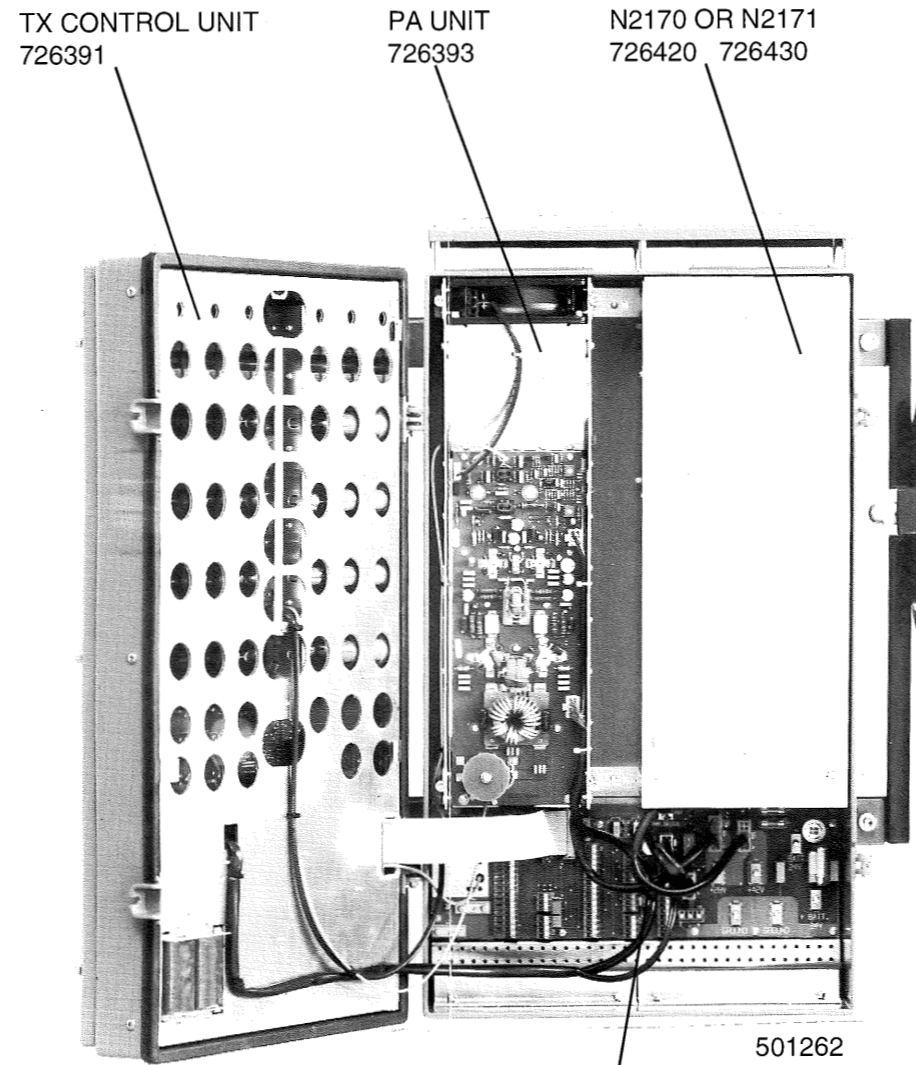

501262

CONNECTION BOARD (13)
626413

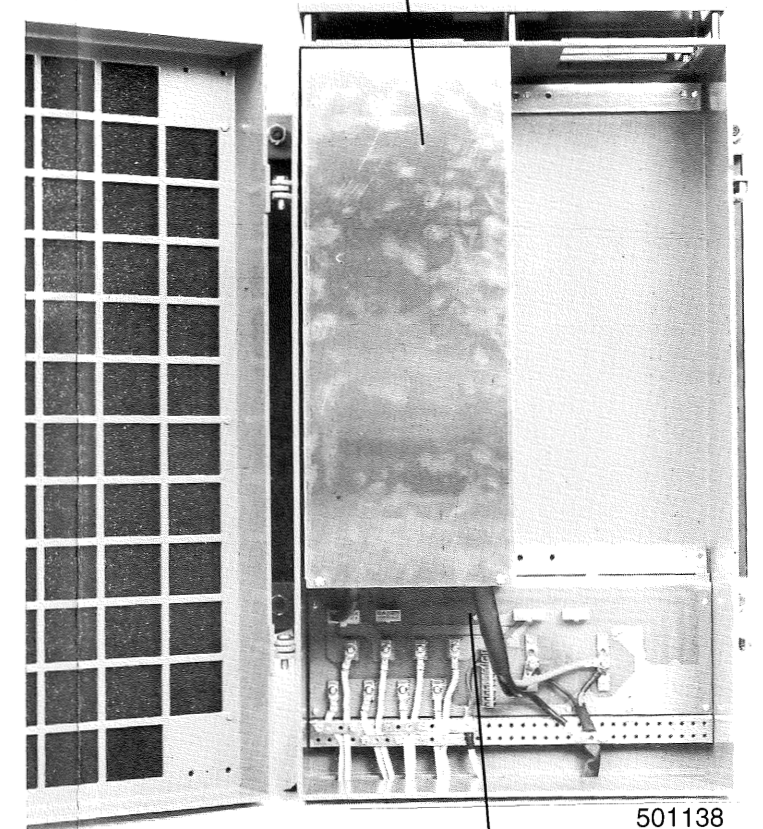

501138

CONNECTION BOARD (5)
626425

CONTENTS

5	CIRCUIT DESCRIPTION AND SCHEMATIC DIAGRAMS	
5.1	CONNECTION BOARD (MODULE 13) PART NO. 626413	5-1
5.2	CONNECTION BOARD (MODULE 5) PART NO. 626425	5-5
5.3	CONN. SINGLE BATTERY CHARGER (MODULE 3) PART NO. 626446	5-9
5.4	CONN. DUAL BATTERY CHARGER (MODULE 4) PART NO. 626447	5-13
5.5	REMOTE CONTROL UNIT H2180 FOR N2174 BATTERY CHARGER	5-17
5.6	FUSE BOX H2182	5-18

5 CIRCUIT DESCRIPTION AND SCHEMATIC DIAGRAMS

5.1 CONNECTION BOARD (MODULE 13) PART NO. 626413

The connection board contains following circuits:

Aerial switch relays RE3 and RE4. In transmit mode is RE3 and RE4 activated. The output from the power amplifier (filter switch) is fed through RE4 to the aerial coupler AT2112 / the antenna.

The output from the RE2100 (exciter) is fed through RE3 to the power amplifier.

The power-in detector consists of the amplifier Q1 and the detector D4, C34.

This detector is used to measure whether the input from RE2100 is sufficient. It is also used together with the power out detector to check if the power amplifier is working ok.

The audiotransformers for aux AF to transmitter and 0 dBm input.

The optocoupler's OC1, OC2 is used for controlling the transmitter in telex mode.

When OC1 is on, then the power supply is switch on and the transmitter is ready to transmit (this function is not used when SAILOR telex modem RM2151 is used, then this is done via the SP-BUS).

OC1 is a fast on/off switch for the RF signal, and is used for ARQ telex.

RE1 is a mute relay for external muting. It is activated when the transmitter is ready for transmit, tuning and transmitting.

RE2 is a mute relay for muting of the receiver in RE2100. It has to activated when other transmitters is used on the same installation.

COMPONENT LOCATION CONNECTION BOARD MODULE 13

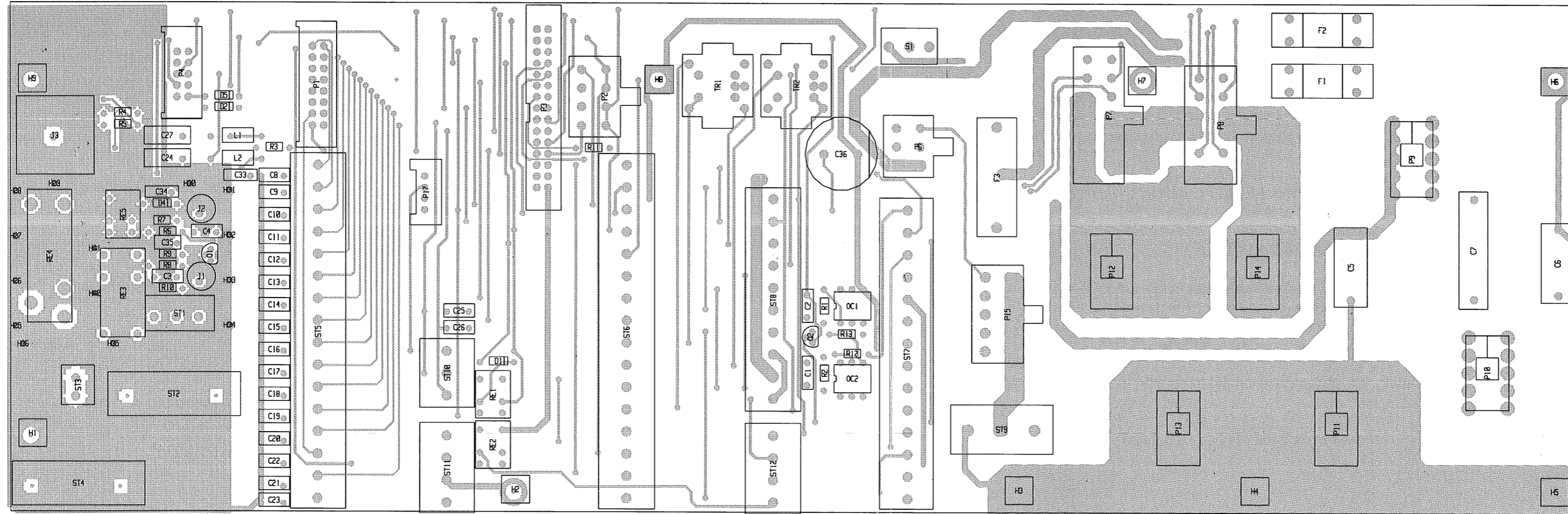

View from component side with upper side tracks.

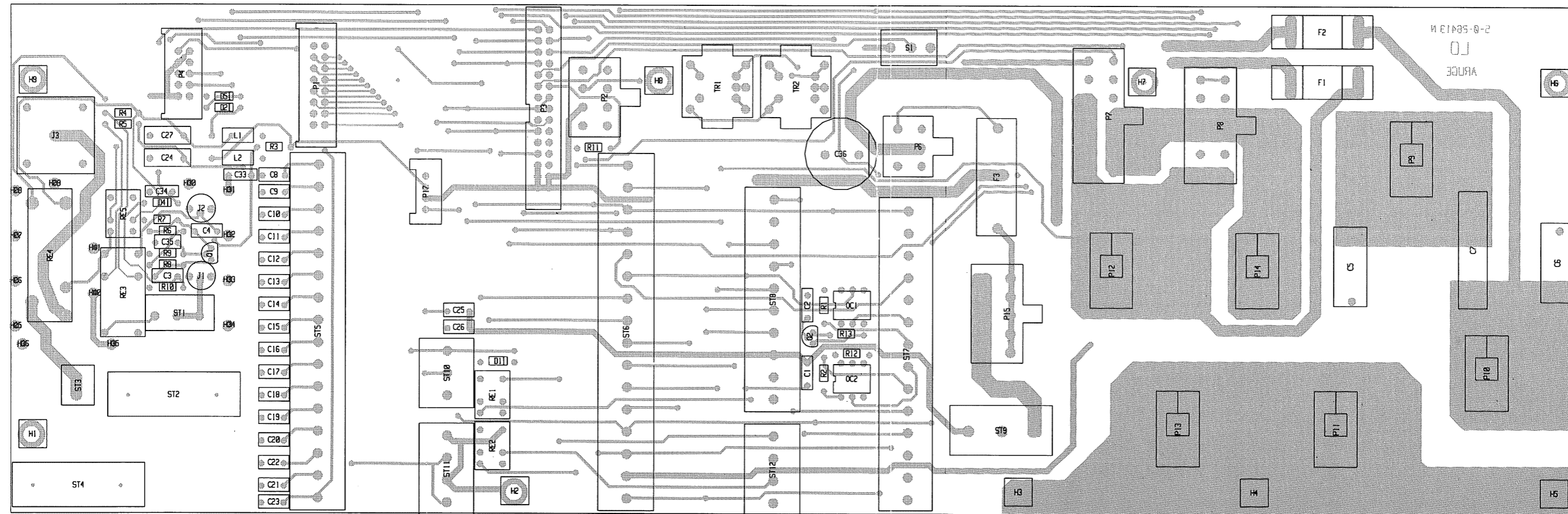

View from component side with lower side tracks.

PCB rev. 26413N

CONNECTION BOARD MODULE 13

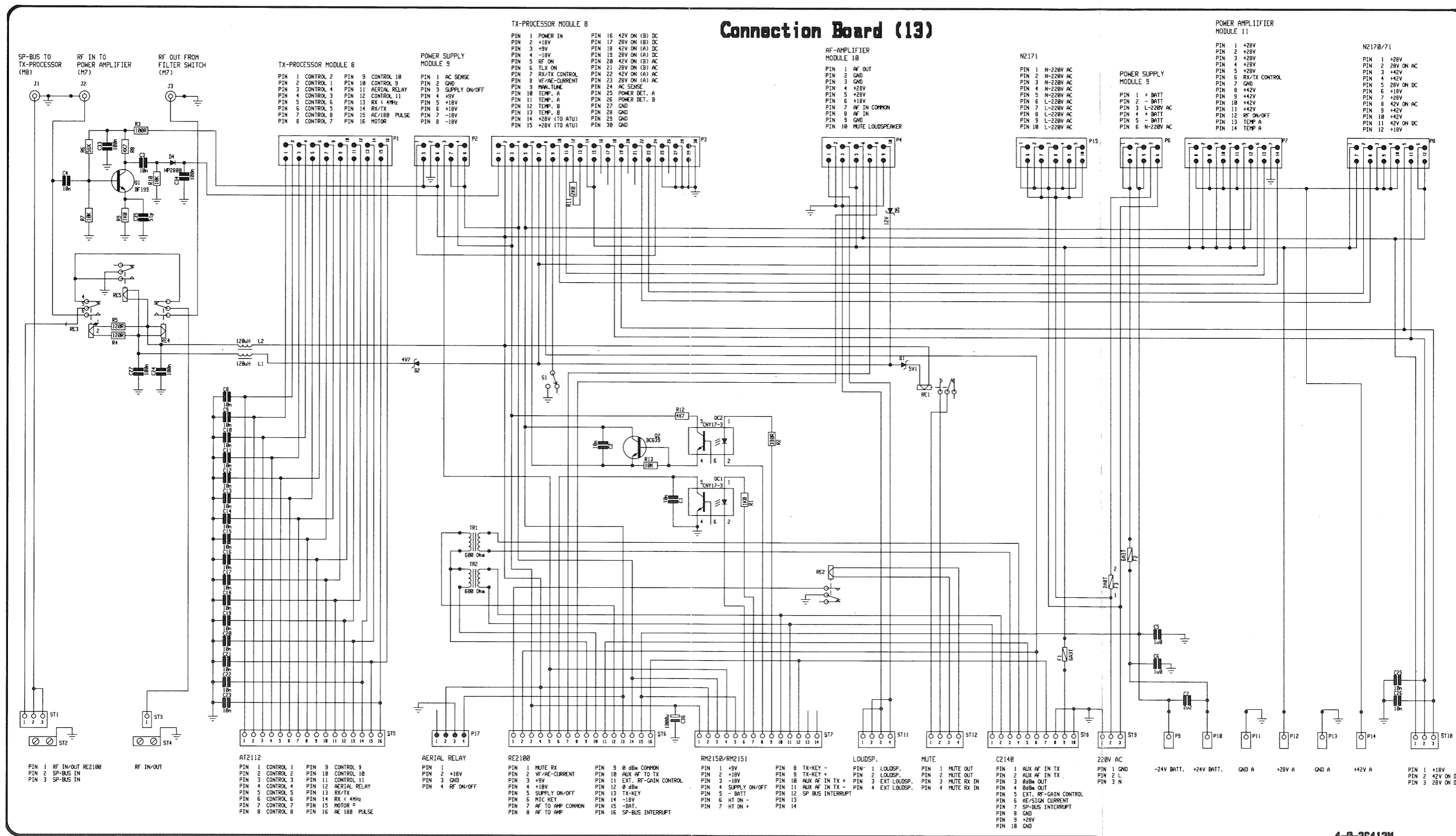

This diagram is valid for PCB rev. 26413M

5.2 CONNECTION BOARD (MODULE 5) PART NO. 626425**CIRCUIT DESCRIPTION**

The connection board (module 5) is a multi connection board intended for connection of different kind of power supply configurations for the 600W or the 1200W transmitter. It can be used for installing a single AC power supply (N2171) or a single DC power supply (N2170) for supplying a 600W transmitter. It can also be used for installing a dual AC power supply (2 x N2171) or a dual DC power supply (2 x N2170) for supplying a 1200W transmitter.

COMPONENT LOCATION CONNECTION BOARD MODULE 5

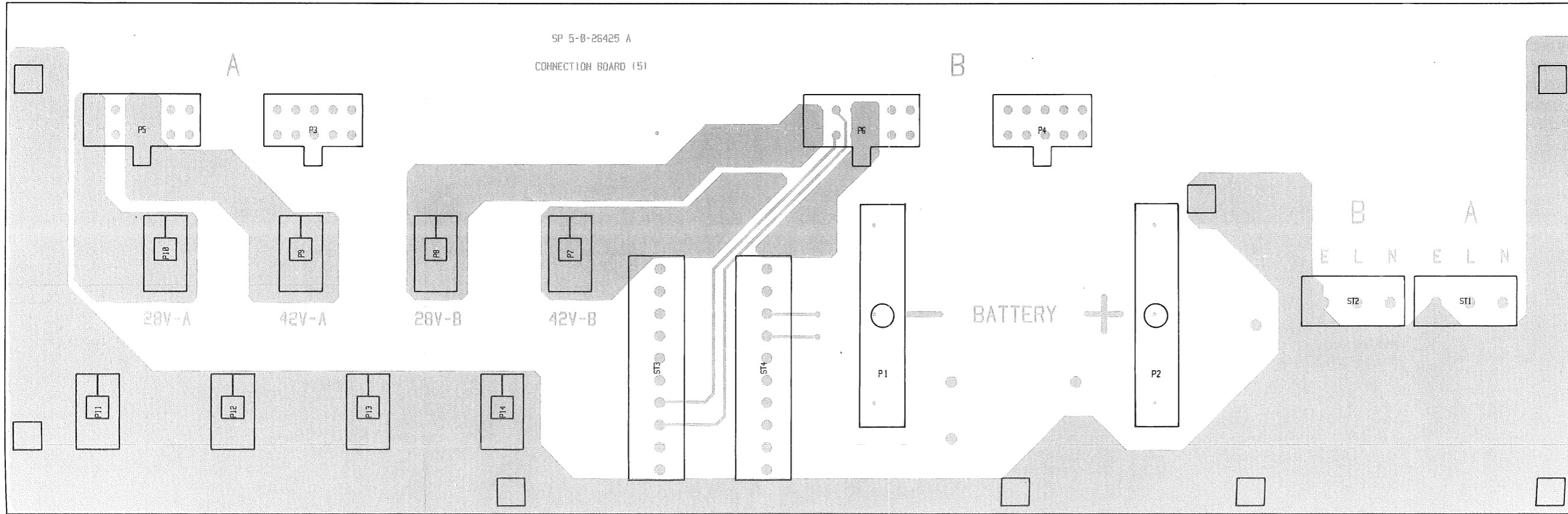

View from component side with upper side tracks.

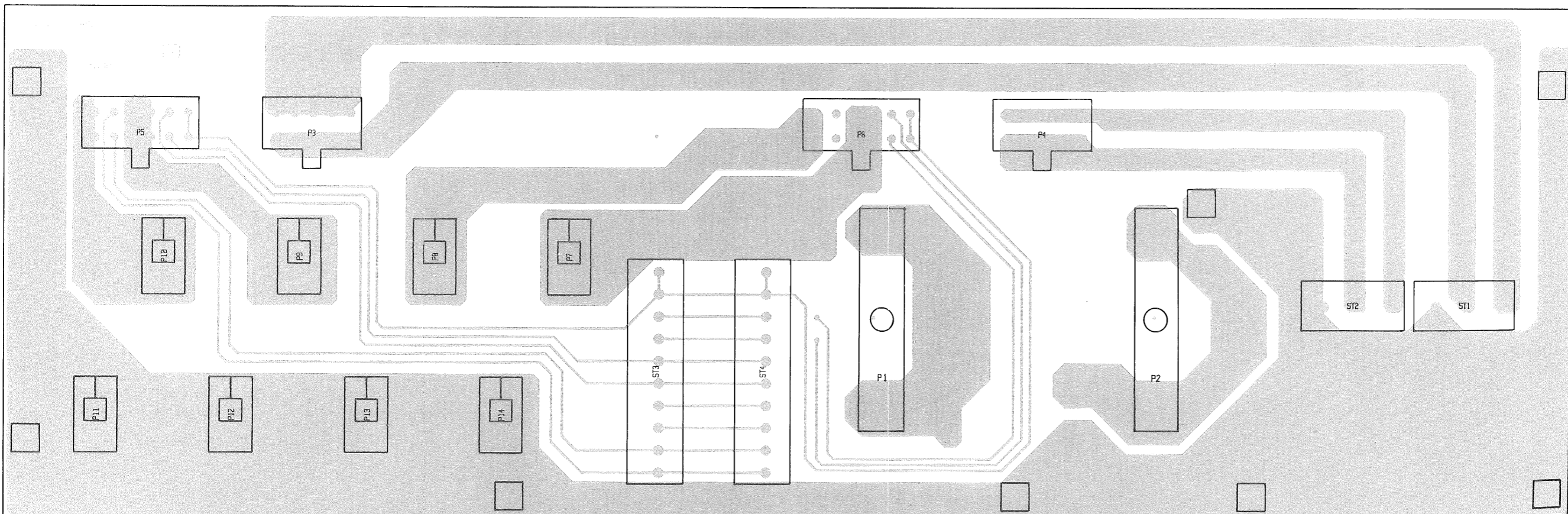

View from component side with lower side tracks.

CONNECTION BOARD MODULE 5

Connection Board (5)

TO PS-A

- PIN 1 AC-N
- PIN 2 AC-N
- PIN 3 AC-N
- PIN 4
- PIN 5
- PIN 6 AC-L
- PIN 7 AC-L
- PIN 8 AC-L
- PIN 9
- PIN 10

TO PS-B

- PIN 1 AC-N
- PIN 2 AC-N
- PIN 3 AC-N
- PIN 4
- PIN 5
- PIN 6 AC-L
- PIN 7 AC-L
- PIN 8 AC-L
- PIN 9
- PIN 10

TO PS-A

- PIN 1 +28V
- PIN 2 28V ON AC
- PIN 3 +42V
- PIN 4 +42V
- PIN 5 28V ON DC
- PIN 6 +18V
- PIN 7 +28V
- PIN 8 42V ON AC
- PIN 9 +42V
- PIN 10 +42V
- PIN 11 42V ON DC
- PIN 12 +18V

TO PS-B

- PIN 1 +28V
- PIN 2 28V ON AC
- PIN 3 +42V
- PIN 4 +42V
- PIN 5 28V ON DC
- PIN 6 +18V
- PIN 7 +28V
- PIN 8 42V ON AC
- PIN 9 +42V
- PIN 10 +42V
- PIN 11 42V ON DC
- PIN 12 +18V

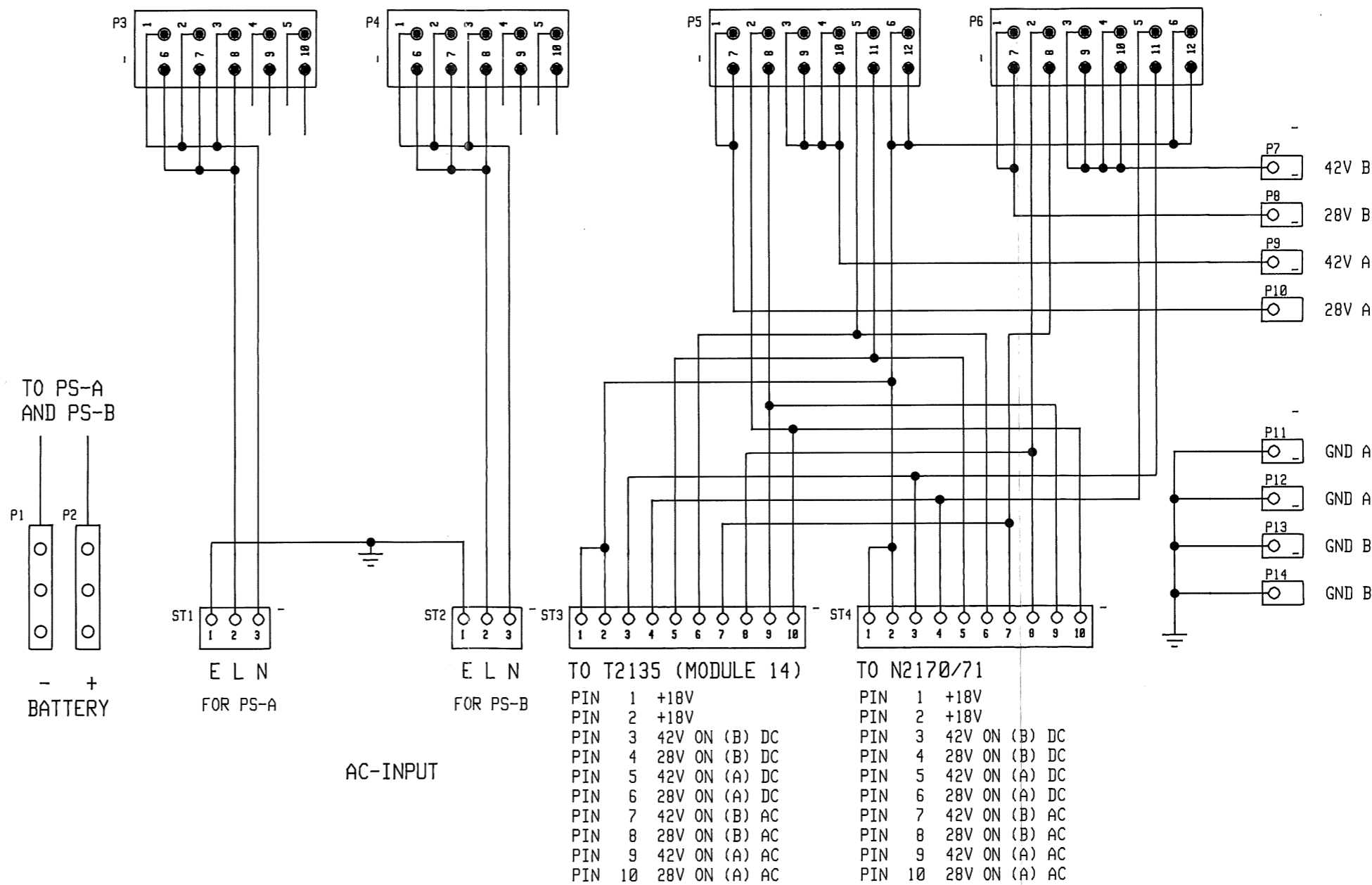

4-0-26425B

4-0-26425B

5.3 CONN. SINGLE BATTERY CHARGER (MODULE 3) PART NO. 626446

CIRCUIT DESCRIPTION

The connection board consist of two part: One part for connection to the power supply N2170 and one part for connection to the BATTERY CHARGER N2174. The part for the N2174 contains the connections for the REMOTE BOX N2180, for the FUSE BOX N2182, for the battery temperature sensor, for the voltage alarms and for an auxillary output.

The battery voltage and the charge current are monitored by the remote voltage sense wires (+VS and -VS) and by the current shunt wires (+SHUNT and -SHUNT), connected to the connection board and led to the REMOTE BOX N2180.

Connections for the voltage alarms can be connected in several ways depending on the need. The relay RE2 is activated by the "26V" from N2174. When the AC mains fails, the "26V" disappears and the relay RE2 falls. This might be used to give alarm for AC mains failure.

The comparator U1 is a **battery low detector**, which switches off the relay RE1, if the battery voltage goes under a preset value set by R2. Normally it is set for detecting battery voltage under 24VDC.

The diode D6 protects against reverse polarity of the battery.

The connection board also contains a **service strapfield**. It might be useful during adjustment of the charger N2174, if the REMOTE BOX H2180 is placed far away. The strapfield has the same function as the switches in H2180. Normally the strap is placed in REMOTE position, which means the H2180 is controlling the N2174. Moving the strap to MAN position means that the N2174 is forced to charge in MANUAL mode. Moving the strap to AUTO position means that the N2174 is forced to charge in AUTOMATIC mode. Remember to move the strap back to REMOTE position when the adjustment of the N2174 is completed.

ADJUSTMENT OF BATTERY LOW DETECTOR

Disconnect the connection board from the battery and connect a power supply to the output terminals for the battery and set it for 24.0VDC. Turn R2 fully counter clockwise and the relay RE1 is activated. Then turn R2 slowly clockwise just until the relay RE1 falls. Now the RE1 will fall when battery voltage goes under 24.0V and will not be activated again before the battery voltage is over 25.5V.

no auf Coia eingebaut

COMPONENT LOCATION CONN. SINGLE BATTERY CHARGER MODULE 3

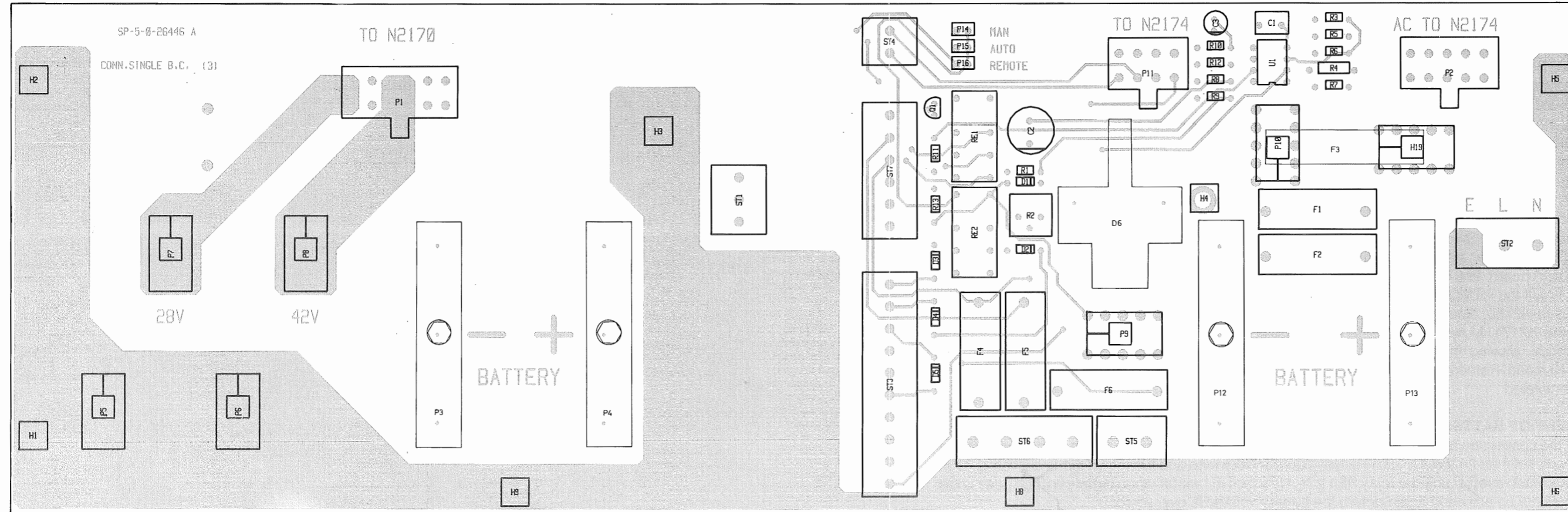

View from component side with upper side tracks.

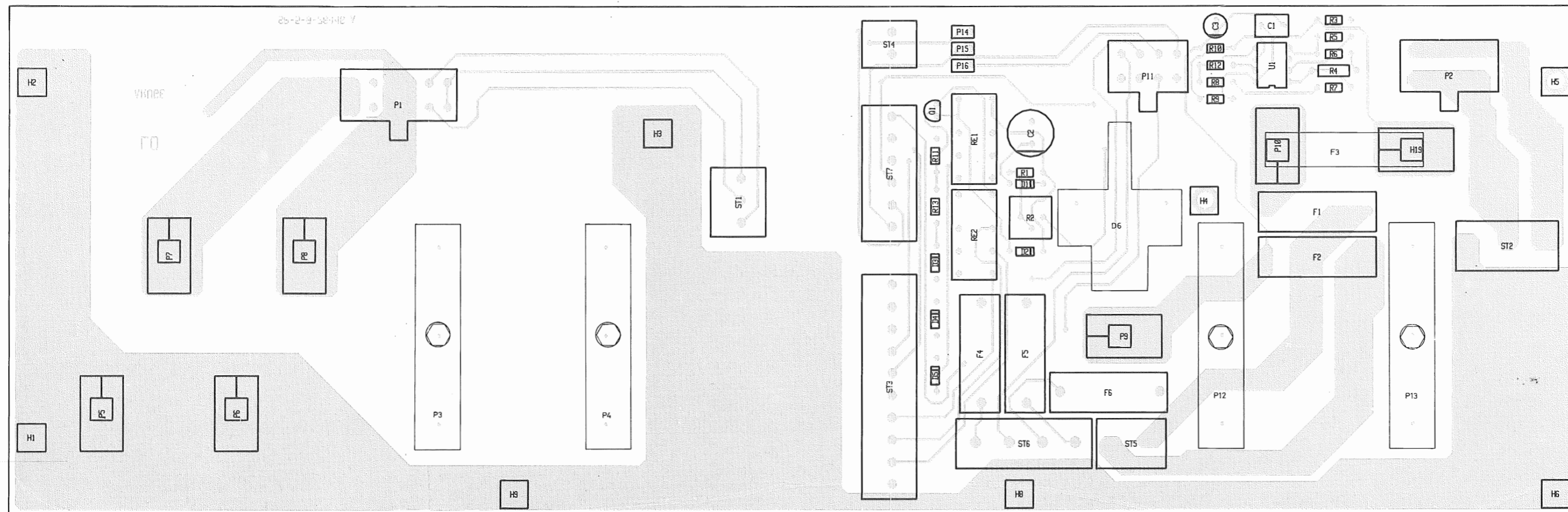

View from component side with lower side tracks.

CONN. SINGLE BATTERY CHARGER MODULE 3

Conn. Single Battery Charger (3)

TO N2170

- PIN 1 +28V
- PIN 2 +42V
- PIN 3 +42V
- PIN 4 +42V
- PIN 5 28V ON
- PIN 6 +18V
- PIN 7 +28V
- PIN 8
- PIN 9 +42V
- PIN 10 +42V
- PIN 11 42V ON
- PIN 12 +18V

TO N2174

- PIN 1 AC-N
- PIN 2 AC-N
- PIN 3 AC-N
- PIN 4
- PIN 5
- PIN 6 AC-L
- PIN 7 AC-L
- PIN 8 AC-L
- PIN 9
- PIN 10

TO N2174

- PIN 1 +VS
- PIN 2 -VS
- PIN 3 26V
- PIN 4 AUTO
- PIN 5 +TS
- PIN 6 -TS
- PIN 7 M/S
- PIN 8 MAN

SERVICE STRAPFIELD

- MAN
- AUTO
- REMOTE

FROM N2174

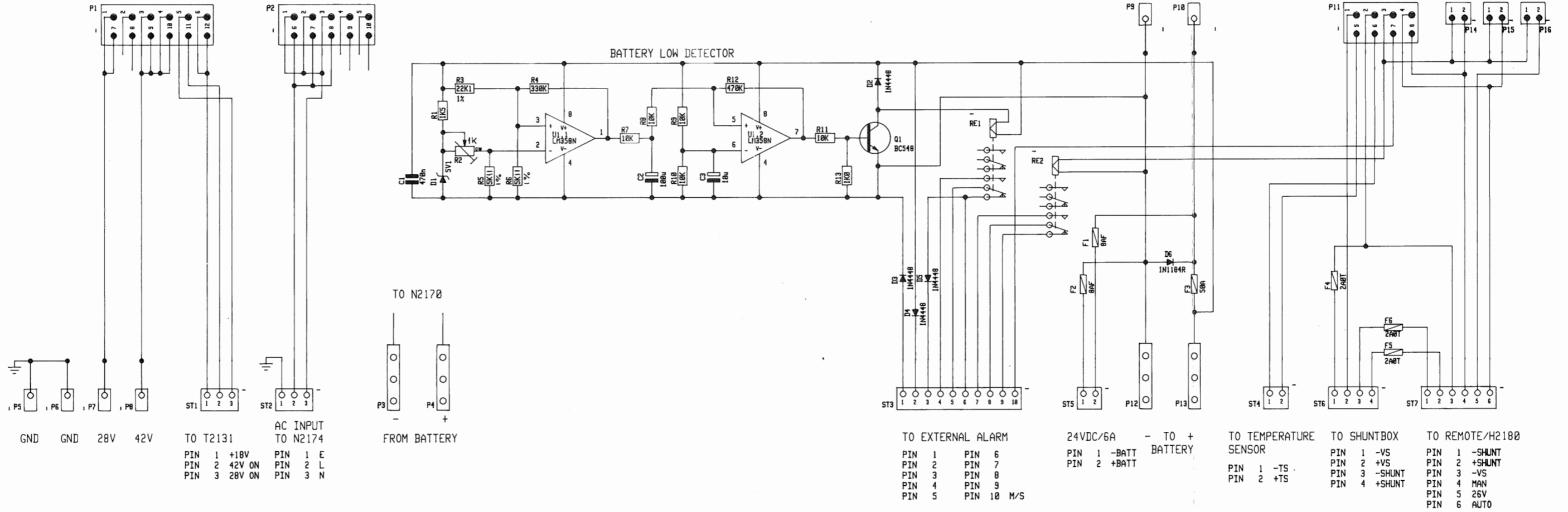

4-8-26446C

4-0-26446C

5.4 CONN. DUAL BATTERY CHARGER (MODULE 4) PART NO. 626447

CIRCUIT DESCRIPTION

The connection board consist of two equal parts. One part for each N2174. The two N2174 can be connected as two separate and independent chargers, but the two N2174 can also be connected in parallel (DUAL) to form a high current charger of 60A. In DUAL operation the outputs from both N2174 are connected together. One N2174 is designated MASTER and the other N2174 as SLAVE. The designation is determined by a strap placed in the AUTOMATIC module in N2174 (see circuit description for that module). On the connection board the SLAVE unit is connected to the MASTER unit by three wires. That is the MAN wire (ST5 pin 4 to ST11 pin 4), the AUTO wire (ST5 pin 6 to ST11 pin 6) and the M/S wire (ST1 pin 10 to ST7 pin 10). In DUAL operation only the MASTER part of the connection board (normally designated N2174-II) is connected to the environment. It contains all the connections for the REMOTE BOX N2180, for the FUSE BOX N2182, for the battery temperature sensor, for the voltage alarms and for an auxillary output.

The battery voltage and the charge current are monitored by the remote voltage sense wires (+VS and -VS) and by the current shunt wires (+SHUNT and -SHUNT), connected to the connection board and led to the REMOTE BOX N2180.

Connections for the voltage alarms can be connected in several ways depending on the need. The relay RE4 is activated by the "26V" from N2174. When the AC mains fails, the "26V" disappears and the relay RE4 falls. This might be used to give alarm for AC mains failure.

The comparator U2 is a **battery low detector**, which switches off the relay RE3, if the battery voltage goes under a preset value set by R16. Normally it is set for detecting battery voltage under 24VDC.

The diodes D6 and D12 protects against reverse polarisation of the battery.

The connection board also contains a **service strapfield**. It might be useful during adjustment of the charger N2174, if the REMOTE BOX H2180 is placed far away. The strapfield has the same function as the switches in H2180. Normally the strap is placed in REMOTE position, which means the H2180 is controlling the N2174. Moving the strap to MAN position means that the N2174 is forced to charge in MANUAL mode. Moving the strap to AUTO position means that the N2174 is forced to charge in AUTOMATIC mode. Remember to move the strap back to REMOTE position when the adjustment of the N2174 is completed.

ADJUSTMENT OF BATTERY LOW DETECTOR

Disconnect the connection board from the battery and connect a power supply to the output terminals for the battery and set it for 24.0VDC. Turn R16 fully counter clockwise and the relay RE3 is activated. Then turn R16 slowly clockwise just until the relay RE3 falls. Now the RE3 will fall when battery voltage goes under 24.0V and will not be activated again before the battery voltage is over 25.5V.

The other part of the connection board can be adjusted in the samme way.

COMPONENT LOCATION CONN. DUAL BATTERY CHARGER MODULE 4

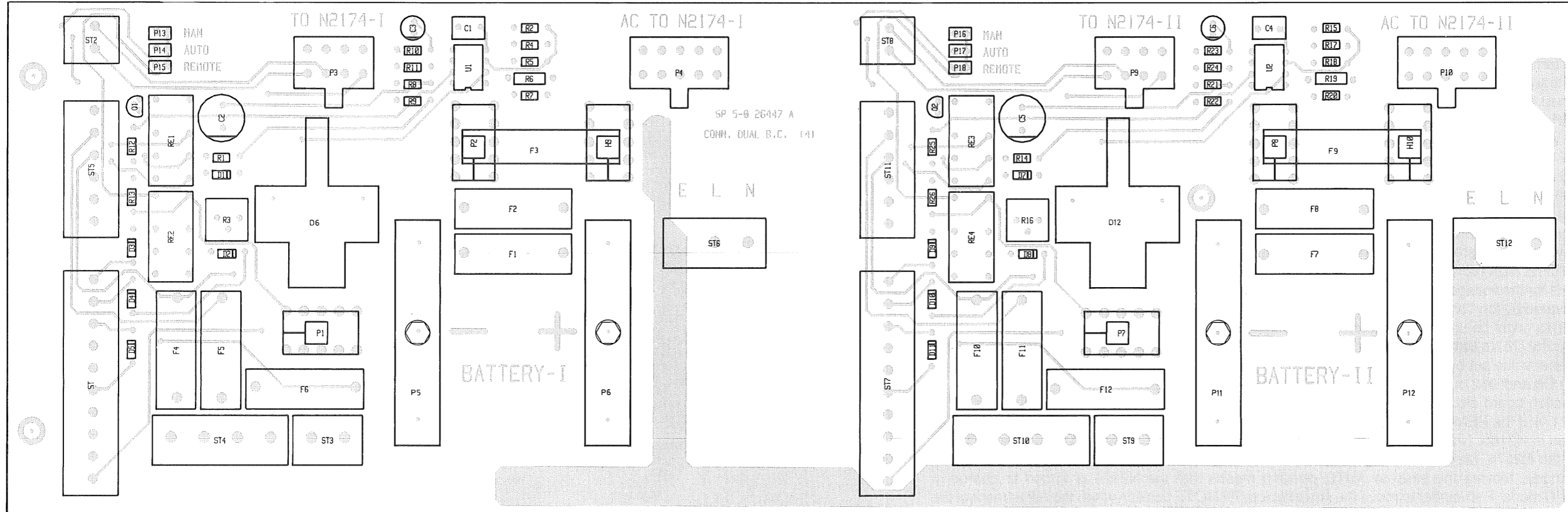

View from component side with upper side tracks.

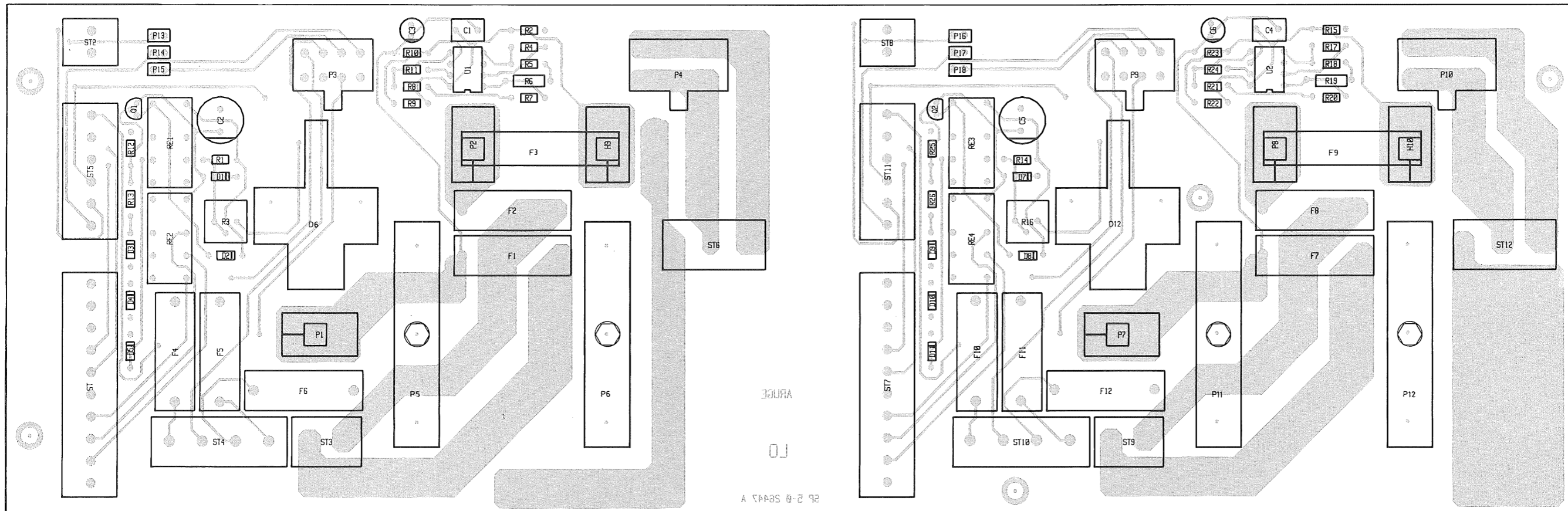

View from component side with lower side tracks.

CONN. DUAL BATTERY CHARGER MODULE 4

Conn. Dual Battery Charger (4)

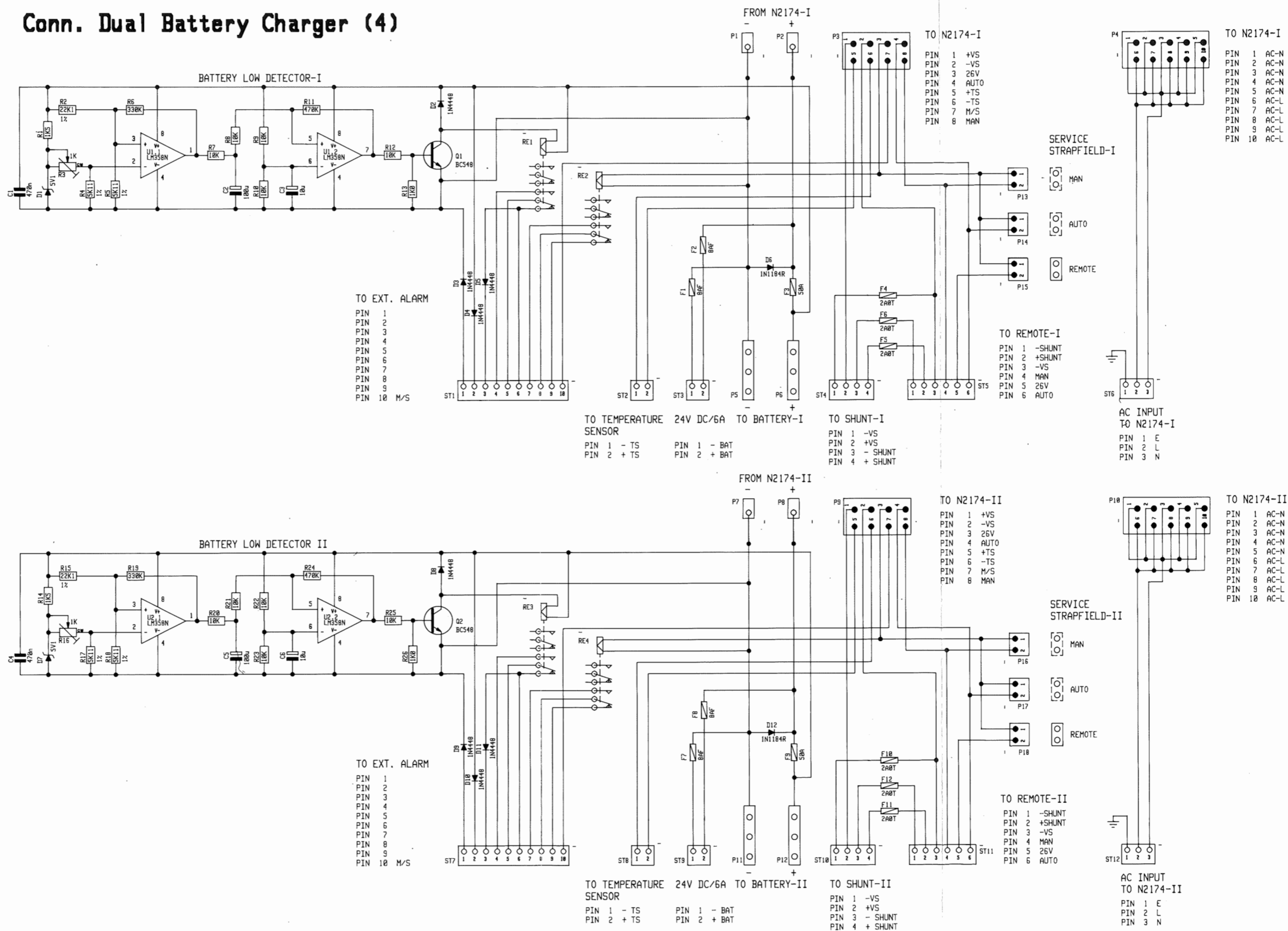

4-0-26447A

4-0-26447A

5.5 REMOTE CONTROL UNIT H2180 FOR N2174 BATTERY CHARGER

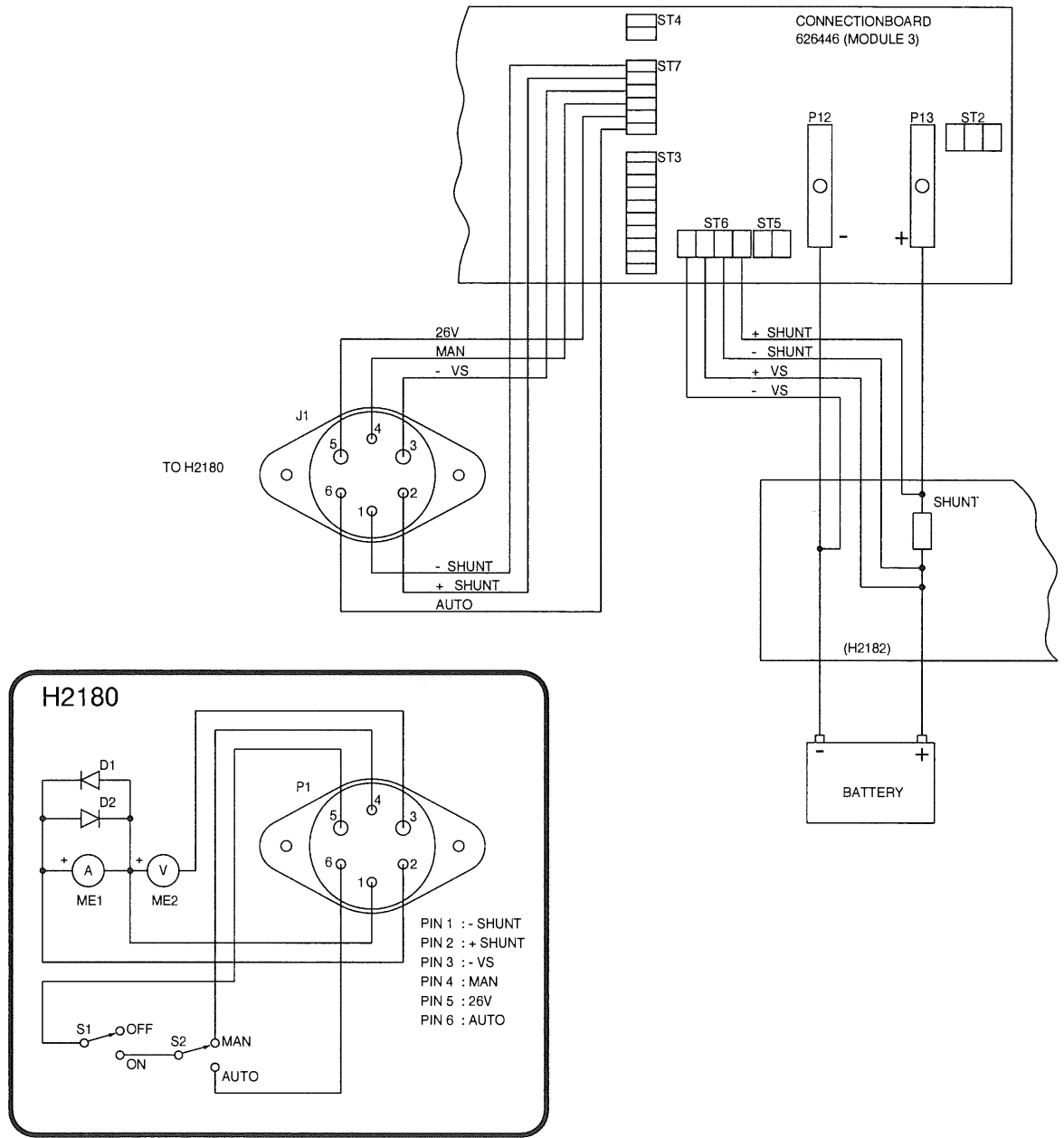

28223

5.6 FUSE BOX H2182

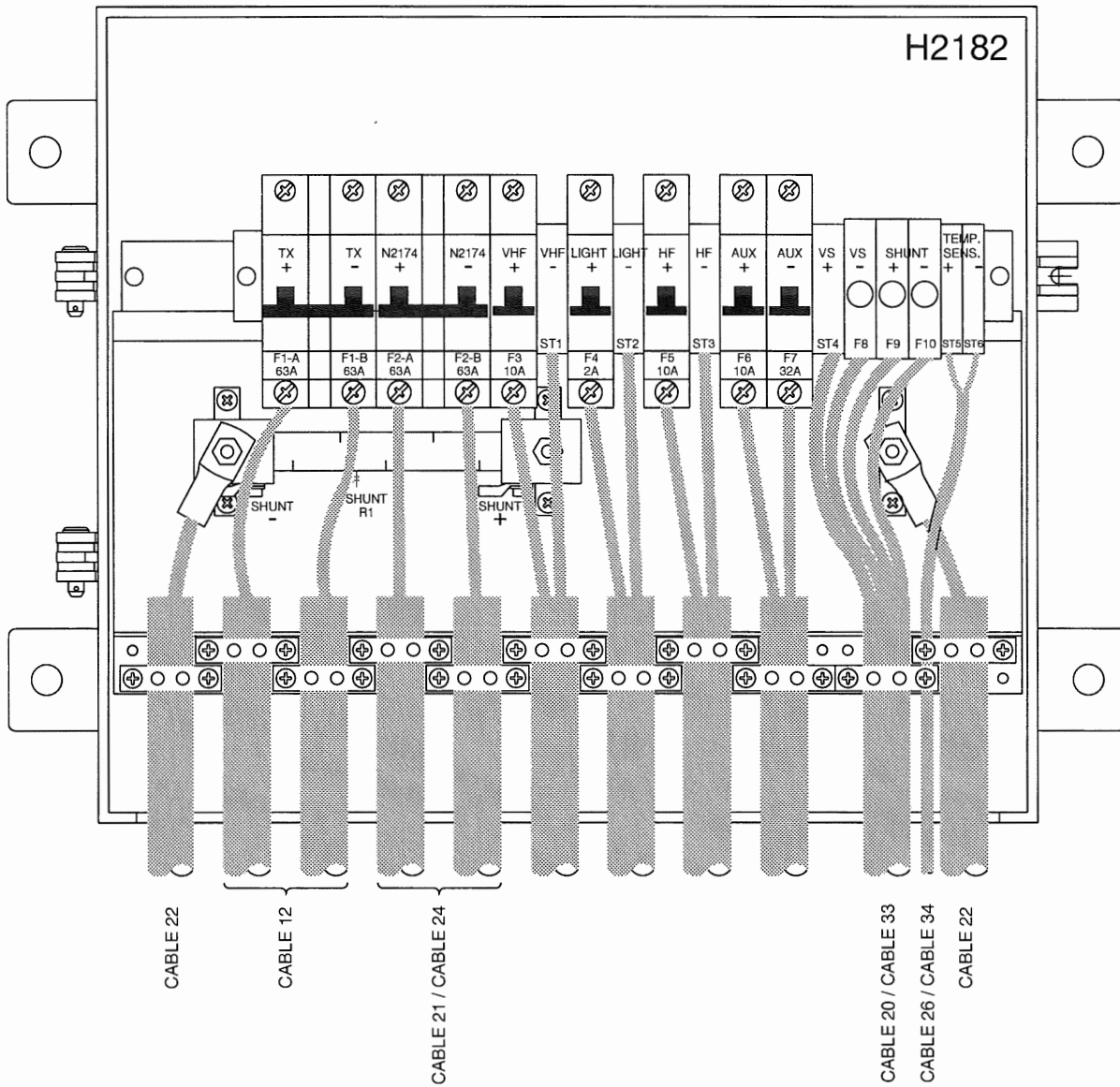

28288A

DIAGRAM FOR FUSE BOX H2182

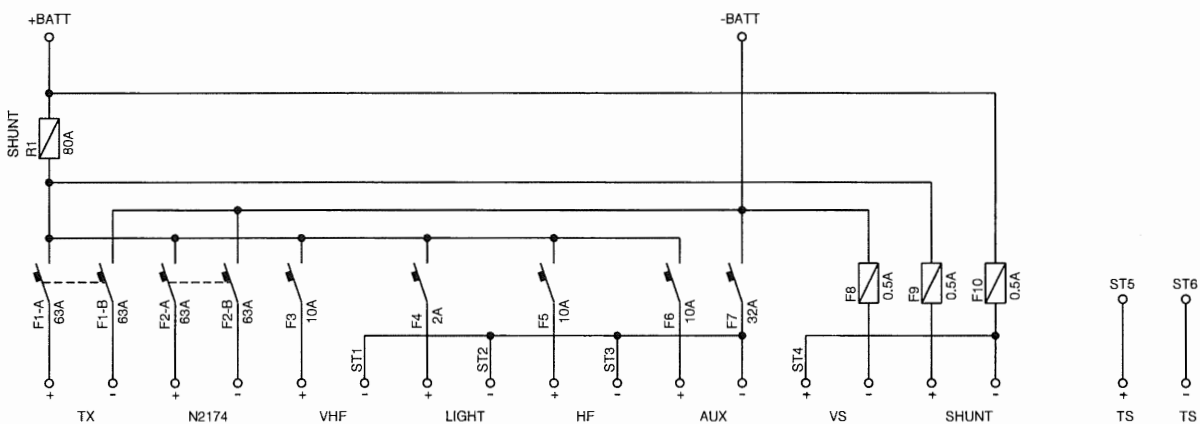

28289A

5.7 FUSE BOX H2182A

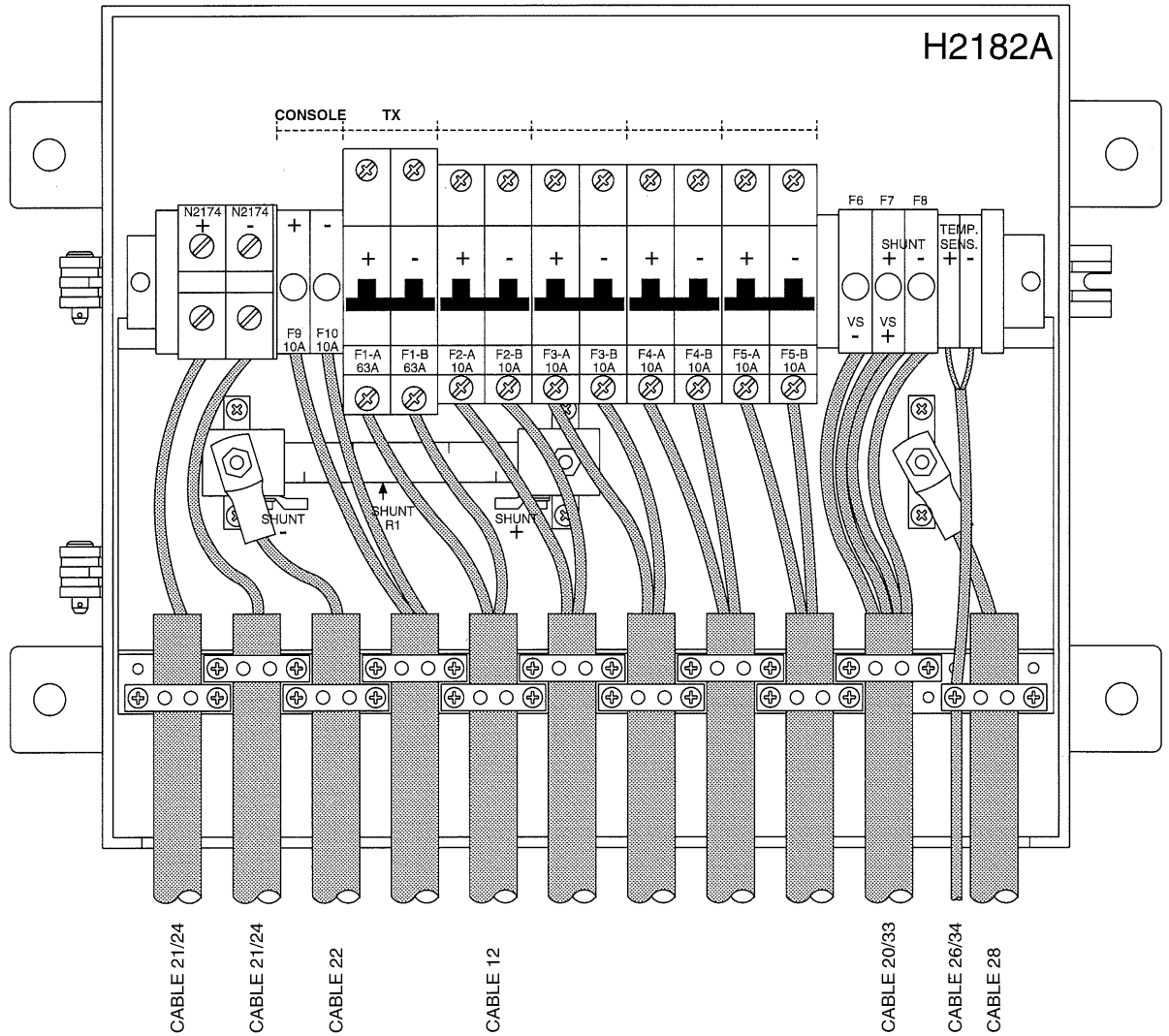

32047

DIAGRAM FOR FUSE BOX H2182A

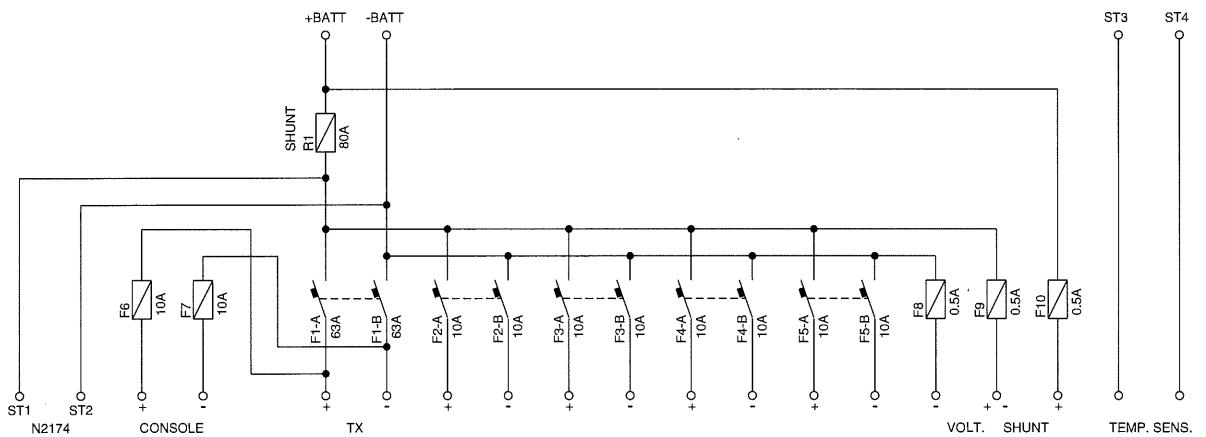

32066

5.8 FUSE BOX H2183A

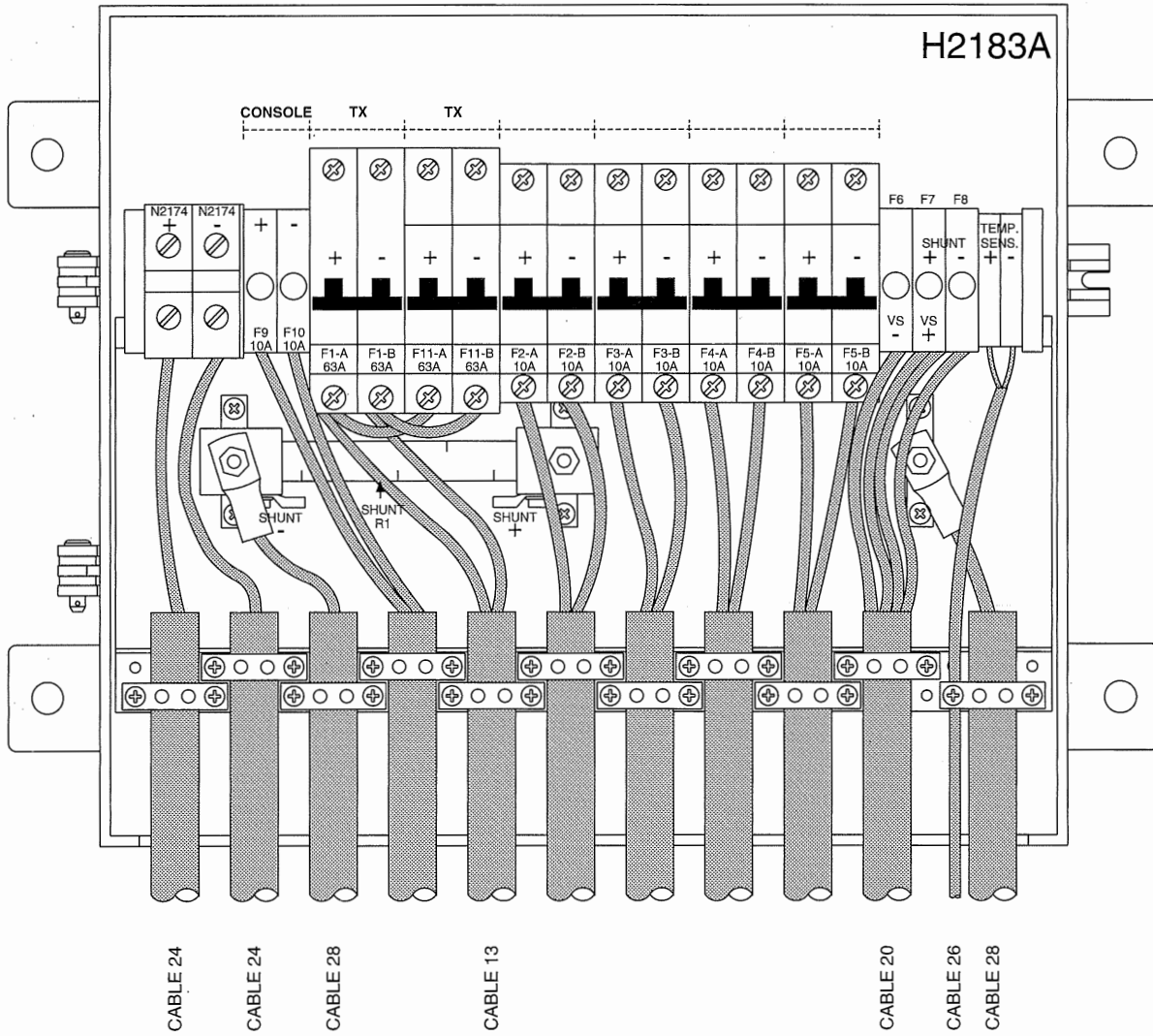

32048

DIAGRAM FOR FUSE BOX H2183A

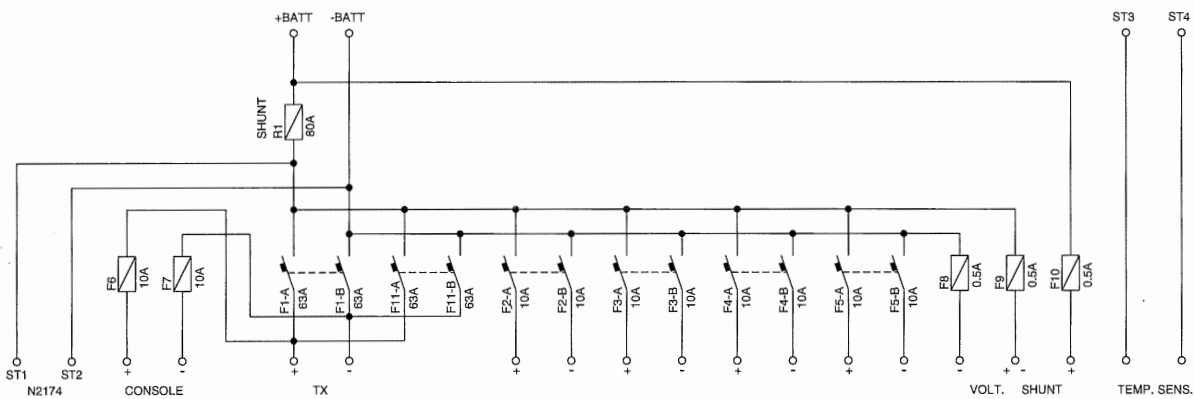

32067

CONTENTS

6 PARTS LISTS

6-1

GRØN SIDE

6 PARTS LISTS

CONNECTION BOARD 600W		T2131-N2170/N2171	ECI A/S	0-0-26395	726395
POSITION	DESCRIPTION		MANUFACTOR	TYPE	PART NO.
VARIOUS	RF COVER - CON. BOARD	CONNECTIONBOARD 26413/14	ECI A/S	1-0-26869	226869
VARIOUS	COAX CABLE Ø3x50cm		ECI A/S	0-0-26918	526918
VARIOUS	DISTANCE PIECE	Ø4.8x0.8x8mm	OJD	4,8X0,8X8 MESS.	63.106
VARIOUS	SPARE FUSES F.N2165/HFSSB	N2165	S.P.RADIO	0-0-27245	727245
VARIOUS	KIT, WASHERS AND NUTS.FOR	CONNECTION BOARD 6/1200W	ECI A/S	0-0-27676	727676
VARIOUS	SCREW M3x12mm PHJX-Z	DIN 7985	HFC	HFC9041 M3x12 PHJX-Z DIN 7985	86.956
-13	CONNECTION BOARD MODUL.13	T2131/N2170/N2171 - 600W	ECI A/S	5-0-26413N / 4-0-26413M	626413
CONNECTION BOARD MODUL.13		T2131/N2170/N2171 - 600W	ECI A/S	5-0-26413N / 4-0-26413M	626413
POSITION	DESCRIPTION		MANUFACTOR	TYPE	PART NO.
VARIOUS	FUSE COVER	5x20mm FUSE SIZE	ELU	199016	48.716
VARIOUS	FUSE HOLDER	FOR PCB	SHURTER	OG 751 0042	78.421
VARIOUS	SCREW M3x12mm PHJX-Z	DIN 7985	HFC	HFC9041 M3x12 PHJX-Z DIN 7985	86.956
VARIOUS	SCREW M3x16 PHJX-Z	DIN 7985	WULCAN	HFC 9041 M3x16 PHJX-Z DIN 7985	86.957
VARIOUS	SCREW	M5x12 STEEL	HFC	HFC 473 FORZ.	87.413
C1-13	CAPACITOR MKT	10nF 5% 63VDC	PHILIPS	2222 370 89103	11.134
C2-13	CAPACITOR MKT	10nF 5% 63VDC	PHILIPS	2222 370 89103	11.134
C3-13	CAPACITOR CERAMIC	10nF -20/+80% CL2 50VDC	KCK	RT-HE70 SK YF 103 Z	15.170
C4-13	CAPACITOR CERAMIC	10nF -20/+80% CL2 50VDC	KCK	RT-HE70 SK YF 103 Z	15.170
C5-13	CAPACITOR MKT	1u0F 10% 100VDC	PHILIPS	2222 373 21105	11.079
C6-13	CAPACITOR MKT	1u0F 10% 100VDC	PHILIPS	2222 373 21105	11.079
C7-13	CAPACITOR MKT	2u2F 10% 100VDC	ERO	MKT 1822-522/01 5	11.142
C8-13	CAPACITOR CERAMIC	10nF -20/+80% CL2 50VDC	KCK	RT-HE70 SK YF 103 Z	15.170
C9-13	CAPACITOR CERAMIC	10nF 20/+80% CL2 50VDC	KCK	RT-HE70 SK YF 103 Z	15.170
C10-13	CAPACITOR CERAMIC	10nF -20/+80% CL2 50VDC	KCK	RT-HE70 SK YF 103 Z	15.170
C11-13	CAPACITOR CERAMIC	10nF -20/+80% CL2 50VDC	KCK	RT-HE70 SK YF 103 Z	15.170
C12-13	CAPACITOR CERAMIC	10nF -20/+80% CL2 50VDC	KCK	RT-HE70 SK YF 103 Z	15.170
C13-13	CAPACITOR CERAMIC	10nF -20/+80% CL2 50VDC	KCK	RT-HE70 SK YF 103 Z	15.170
C14-13	CAPACITOR CERAMIC	10nF -20/+80% CL2 50VDC	KCK	RT-HE70 SK YF 103 Z	15.170
C15-13	CAPACITOR CERAMIC	10nF -20/+80% CL2 50VDC	KCK	RT-HE70 SK YF 103 Z	15.170
C16-13	CAPACITOR CERAMIC	10nF -20/+80% CL2 50VDC	KCK	RT-HE70 SK YF 103 Z	15.170
C17-13	CAPACITOR CERAMIC	10nF -20/+80% CL2 50VDC	KCK	RT-HE70 SK YF 103 Z	15.170
C18-13	CAPACITOR CERAMIC	10nF -20/+80% CL2 50VDC	KCK	RT-HE70 SK YF 103 Z	15.170
C19-13	CAPACITOR CERAMIC	10nF -20/+80% CL2 50VDC	KCK	RT-HE70 SK YF 103 Z	15.170
C20-13	CAPACITOR CERAMIC	10nF -20/+80% CL2 50VDC	KCK	RT-HE70 SK YF 103 Z	15.170
C21-13	CAPACITOR CERAMIC	10nF -20/+80% CL2 50VDC	KCK	RT-HE70 SK YF 103 Z	15.170
C22-13	CAPACITOR CERAMIC	10nF -20/+80% CL2 50VDC	KCK	RT-HE70 SK YF 103 Z	15.170
C23-13	CAPACITOR CERAMIC	10nF -20/+80% CL2 50VDC	KCK	RT-HE70 SK YF 103 Z	15.170
C24-13	CAPACITOR MKT	100nF 10% 100VDC	ERO	MKT 1818-410/01 5-G	11.180
C25-13	CAPACITOR CERAMIC	10nF -20/+80% CL2 50VDC	KCK	RT-HE70 SK YF 103 Z	15.170
C26-13	CAPACITOR CERAMIC	10nF -20/+80% CL2 50VDC	KCK	RT-HE70 SK YF 103 Z	15.170
C27-13	CAPACITOR MKT	100nF 10% 100VDC	ERO	MKT 1818-410/01 5-G	11.180
C33-13	CAPACITOR MKT	0.1uF 10% 63VDC	PHILIPS	2222 370 78104	11.136
C34-13	CAPACITOR MKT	0.1uF 10% 63VDC	PHILIPS	2222 370 78104	11.136
C35-13	CAPACITOR CERAMIC	51pF 5% NPO 50VDC	KCK	RT-HE60-SK CH 510 J	15.110
C36-13	CAPACITOR ELECTROLYTIC	1000uF -10/+50% 25VDC	ERO	EKM 05 JG 410 E 05	14.600
D1-13	DIODE ZENER	5.1V 5% 0.4W BZX79C5V1	PHILIPS	BZX79C5V1	26.527
D2-13	DIODE ZENER	4.7V 5% 0.4W BZX79C4V7	PHILIPS	BZX79C4V7	26.524
D4-13	DIODE SCHOTTKY BARRIER	70V/15mA 1N5711/5082-2800	SGS-THOMSON	1N5711	27.500
D5-13	DIODE ZENER	12V 5% 0.4W BZX79C12	PHILIPS*	BZX79C12	26.554
F1-13	FUSE	5x20mm 6A3 T 250V	* ELU	17912006300	45.510
F2-13	FUSE	5x20mm 6A3 T 250V	* ELU	17912006300	45.510
F3-13	FUSE	2AT 250V 5x20mm	WICKMANN	19 195 2AT	45.508
VARIOUS	FUSE HOLDER	1 POLE 5x20mm PCB VERSION	ELU	199015	78.398
J1-13	SOCKET COAX FOR PCB	VERTICAL	TAIKO	TMP-J01X-V6	78.518
J2-13	SOCKET COAX FOR PCB	VERTICAL	TAIKO	TMP-J01X-V6	78.518
J3-13	SOCKET BNC	PCB VERSION	ROSENBERGER	51K102-400 A4	78.444
L1-13	CHOKE FIXED	120uH 10%	SIEMENS	B78108-T1124-K	20.372
L2-13	CHOKE FIXED	120uH 10%	SIEMENS	B78108-T1124-K	20.372

POSITION	DESCRIPTION		MANUFACTURER	TYPE	PART NO.
OC1-13	OPTO COUPLER	CNY17-3	MOTOROLA	CNY17-3	32.533
OC2-13	OPTO COUPLER	CNY17-3	MOTOROLA	CNY17-3	32.533
P1-13	MULTI PLUG	2x8 POLES PCB VERSION	3M	3599-6002 / 7616-6002 JL	78.249
P2-13	MULTIPLUG	2x4 POLES PCB VERSION	MOLEX	39-28-1083	78.218
P3-13	MULTIPLUG	2x15 POLES PCB VERSION	3M	3531-6002 / 7630-6002 JL	78.253
P4-13	PLUG	2x5 POLES	3M	3654-6002 / 7610-6002 JL	78.251
P6-13	MULTIPLUG	2x3 POLES PCB VERSION	MOLEX	39-28-1063	78.217
P7-13	MULTIPLUG	2x7 POLES PCB VERSION	MOLEX	39-28-1143	78.222
P8-13	MULTIPLUG	2x6 POLES PCB VERSION	MOLEX	39-28-1123	78.221
P9-13	CONNECTION ELEMENT	FOR M5 SCREW	ECI A/S	1-0-25860	225860
P10-13	CONNECTION ELEMENT	FOR M5 SCREW	ECI A/S	1-0-25860	225860
P11-13	CONNECTION ELEMENT	FOR M5 SCREW	ECI A/S	1-0-25860	225860
P12-13	CONNECTION ELEMENT	FOR M5 SCREW	ECI A/S	1-0-25860	225860
P13-13	CONNECTION ELEMENT	FOR M5 SCREW	ECI A/S	1-0-25860	225860
P14-13	CONNECTION ELEMENT	FOR M5 SCREW	ECI A/S	1-0-25860	225860
P15-13	MULTIPLUG	2x5 POLES PCB VERSION	MOLEX	39-28-1103	78.220
P17-13	PLUG (MALE)	4 POLE	AMP	0-826375-4	78.104
Q1-13	TRANSISTOR RF	BF199	PHILIPS	BF199	28.178
Q2-13	TRANSISTOR AF	NPN BC639 TO-92	PHILIPS	BC639	28.120
R1-13	RESISTOR MF	1k0 OHM 5% 0.33W	PHILIPS	2322 187 73102	02.472
R2-13	RESISTOR MF	390 OHM 5% 0.33W	PHILIPS	2322 187 73391	02.462
R3-13	RESISTOR MF	100 OHM 5% 0.33W	PHILIPS	2322 187 73101	02.448
R4-13	RESISTOR MF	120 OHM 5% 0.33W	PHILIPS	2322 187 73121	02.450
R5-13	RESISTOR MF	120 OHM 5% 0.33W	PHILIPS	2322 187 73121	02.450
R6-13	RESISTOR MF	56k OHM 5% 0.33W	PHILIPS	2322 187 73563	02.514
R7-13	RESISTOR MF	10k OHM 5% 0.33W	PHILIPS	2322 187 73103	02.496
R8-13	RESISTOR MF	4k7 OHM 5% 0.33W	PHILIPS	2322 187 73472	02.488
R9-13	RESISTOR MF	1k0 OHM 5% 0.33W	PHILIPS	2322 187 73102	02.472
R10-13	RESISTOR MF	10k OHM 5% 0.33W	PHILIPS	2322 187 73103	02.496
R11-13	RESISTOR MF	2k0 OHM 5% 0.33W	PHILIPS	2322 187 73202	02.479
R12-13	RESISTOR MF	4k7 OHM 5% 0.33W	PHILIPS	2322 187 73472	02.488
R13-13	RESISTOR MF	10k OHM 5% 0.33W	PHILIPS	2322 187 73103	02.496
RE1-13	RELAY	12VDC 1SH. 2A.	ORIGINAL ELEC	OUC-SS-112D (-S/-SH-)	21.300
RE2-13	RELAY	12VDC 1SH. 2A.	ORIGINAL ELEC	OUC-SS-112D (-S/-SH-)	21.300
RE3-13	RELAY	15V DC 2A 1SH.	SIEMENS	V23040-A0003-B201	21.062
RE4-13	RELAY	12VDC 1SH. 8A.	SCHRACK	RY S 12 012	21.031
RE5-13	RELAY	12VDC 1SH. 2A.	ORIGINAL ELEC	OUC-SS-112D (-S/-SH-)	21.300
S1-13	SWITCH TOGGLE	SPDT ON-ON	C&K	7101-S-Y-C-Q-E	43.019
ST11-13	TERMINAL BLOCK	4 POLES 1.5mm2	PTR	AK300/4b M.MESS.SKRUER	81.025
ST12-13	TERMINAL BLOCK	4 POLES 1.5mm2	PTR	AK300/4b M.MESS.SKRUER	81.025
ST1-13	TERMINAL BLOCK	3 POLES 1.5mm2	PTR	AK500/3DS m.MESS.SKRUER	81.008
ST2-13			ECI A/S	1-0-23762 *	207607
ST3-13	TERMINAL BLOCK	SINGLE POLE	RIACON	360291	81.028
ST4-13			ECI A/S	1-0-23762 *	207607
ST5-13	TERMINAL BLOCK	16 POLES 1.5mm2	PTR	AK300/16b m.MESS.SKRUER	81.014
ST6-13	TERMINAL BLOCK	16 POLES 1.5mm2	PTR	AK300/16b m.MESS.SKRUER	81.014
ST7-13	TERMINAL BLOCK	14 POLES 1.5mm2	PTR	AK300/14b m.MESS.SKRUER	81.029
ST8-13	TERMINAL BLOCK	10 POLES 1.5mm2	PTR	AK300/10b m.MESS.SKRUER	81.017
ST9-13	TERMINAL BLOCK	3 POLES 2.5mm2	PTR	AK110/3DS m.MESS.SKRUER	81.037
ST10-13	TERMINAL BLOCK	3 POLES 1.5mm2	PTR	AK300/3b m.MESS.SKRUER	81.026
TR1-13	TRAFO AF	1:1 600 OHMS	TDK	L04EE13-C10153	22.500
TR2-13	TRAFO AF	1:1 600 OHMS	TDK	L04EE13-C10153	22.500

CONNEX. BOARD POWER SUPPLY	N2170/71 SINGLE & DUAL	ECI A/S	0-0-26397	726397
-----------------------------------	-----------------------------------	----------------	------------------	---------------

POSITION	DESCRIPTION		MANUFACTURER	TYPE	PART NO.
VARIOUS	DISTANCE PIECE	Ø4.8x0.8x8mm	OJD	4,8X0,8X8 MESS.	63.106
VARIOUS	KIT, WASHERS AND NUTS, FOR	CONNECTION BOARD 6/1200W	ECI A/S	0-0-27676	727676
VARIOUS	SCREW M3x12mm PHJX-Z	DIN 7985	HFC	HFC9041 M3x12 PHJX-Z DIN 7985	86.956
-5	CONNECTION BOARD MODULE 5	N2170/N2171	ECI A/S	5-0-26425A / 4-0-26425B	626425

CONNECTION BOARD MODULE 5		N2170/N2171	ECI A/S	5-0-26425A / 4-0-26425B	626425
POSITION	DESCRIPTION		MANUFACTOR	TYPE	PART NO.
P1-5	CONNECTION BAR N141x		ECI A/S	2-0-25057 *	200878
P2-5	CONNECTION BAR N141x		ECI A/S	2-0-25057 *	200878
P3-5	MULTIPLUG	2x5 POLES PCB VERSION	MOLEX	39-28-1103	78.220
P4-5	MULTIPLUG	2x5 POLES PCB VERSION	MOLEX	39-28-1103	78.220
P5-5	MULTIPLUG	2x6 POLES PCB VERSION	MOLEX	39-28-1123	78.221
P6-5	MULTIPLUG	2x6 POLES PCB VERSION	MOLEX	39-28-1123	78.221
P7-5	CONNECTION ELEMENT	FOR M5 SCREW	ECI A/S	1-0-25860	225860
P8-5	CONNECTION ELEMENT	FOR M5 SCREW	ECI A/S	1-0-25860	225860
P9-5	CONNECTION ELEMENT	FOR M5 SCREW	ECI A/S	1-0-25860	225860
P10-5	CONNECTION ELEMENT	FOR M5 SCREW	ECI A/S	1-0-25860	225860
P11-5	CONNECTION ELEMENT	FOR M5 SCREW	ECI A/S	1-0-25860	225860
P12-5	CONNECTION ELEMENT	FOR M5 SCREW	ECI A/S	1-0-25860	225860
P13-5	CONNECTION ELEMENT	FOR M5 SCREW	ECI A/S	1-0-25860	225860
P14-5	CONNECTION ELEMENT	FOR M5 SCREW	ECI A/S	1-0-25860	225860
ST1-5	TERMINAL BLOCK	3 POLES 2.5mm2	PTR	AK110/3DS m.MESS.SKRUER	81.037
ST2-5	TERMINAL BLOCK	3 POLES 2.5mm2	PTR	AK110/3DS m.MESS.SKRUER	81.037
ST3-5	TERMINAL BLOCK	10 POLES 1.5mm2	PTR	AK300/10b m.MESS.SKRUER	81.017
ST4-5	TERMINAL BLOCK	10 POLES 1.5mm2	PTR	AK300/10b m.MESS.SKRUER	81.017

CONNECTION BOARD N2174 SINGLE & N2174/N2170			S.P.RADIO A/S	0-0-26398	726398
POSITION	DESCRIPTION		MANUFACTOR	TYPE	PART NO.
VARIOUS	DISTANCE PIECE	Ø4.8x0.8x8mm	OJD	4,8X0,8X8 MESS.	63.106
VARIOUS	SPARE FUSES FOR CON.BOARD	CONNECTION BOARDS	S.P.RADIO	0-0-27794	727794
VARIOUS	SCREW M3x12mm PHJX-Z	DIN 7985	HFC	HFC9041 M3x12 PHJX-Z DIN 7985	86.956
-3	CONNECTION SINGLE BATTERY	CHARGER(MODULE 3)N2170/74	ECI A/S	5-0-26446B / 4-0-26446C	626446
D6-3	DIODE POW.RECT.35A/100VDC	1N1184R/BYX52-300R	INT.RECTIFIER	1N1184R INCL.HARDWARE (1N1185R,-86R,---,-90R)	25.165
F3-3	FUSE	50A 11x41mm	BOSCH	1 191 017 005 DIN 72 581 - B 50	45.702
R1	SHUNT 80A-75mV		SIFAM	SHUNT MEDIUM CURRENT 80A-75mV	23.160

CONNECTION SINGLE BATTERY CHARGER(MODULE 3)N2170/74			ECI A/S	5-0-26446B / 4-0-26446C	626446
POSITION	DESCRIPTION		MANUFACTOR	TYPE	PART NO.
C1-3	CAPACITOR MKT	470nF 20% 63VDC	ERO	MKT 1826-447/06 6-G	11.188
C2-3	CAPACITOR ELECTROLYTIC	100uF -10/+50% 25VDC	ERO	EKM 00 CC 310 E G5	14.610
C3-3	CAPACITOR ELECTROLYTIC	10uF 20% 35VDC	ELNA	RJ2-35-V-100-M-T34(T58)	14.512
D1-3	DIODE ZENER	5.1V 5% 0.4W BZX79C5V1	PHILIPS	BZX79C5V1	26.527
D2-3	DIODE HIGH SPEED	1N4448	PHILIPS	1N4448	25.147
D3-3	DIODE HIGH SPEED	1N4448	PHILIPS	1N4448	25.147
D4-3	DIODE HIGH SPEED	1N4448	PHILIPS	1N4448	25.147
D5-3	DIODE HIGH SPEED	1N4448	PHILIPS	1N4448	25.147
D6-3	DIODE POW.RECT.35A/100VDC	1N1184R/BYX52-300R	INT.RECTIFIER	1N1184R INCL.HARDWARE (1N1185R,-86R,---,-90R)	25.165
F1-3	FUSE	8AF 250V Ø5x20mm	LITTEL FUSE	217008. TYPE EA	45.561
F2-3	FUSE	8AF 250V Ø5x20mm	LITTEL FUSE	217008. TYPE EA	45.561
F3-3	FUSE	50A 11x41mm	BOSCH	1 191 017 005 DIN 72 581 - B 50	45.702
F4-3	FUSE	2AT 250V 5x20mm	WICKMANN	19 195 2AT	45.508
F5-3	FUSE	2AT 250V 5x20mm	WICKMANN	19 195 2AT	45.508
F6-3	FUSE	2AT 250V 5x20mm	WICKMANN	19 195 2AT	45.508
P1-3	MULTIPLUG	2x6 POLES PCB VERSION	MOLEX	39-28-1123	78.221
P2-3	MULTIPLUG	2x5 POLES PCB VERSION	MOLEX	39-28-1103	78.220
P3-3	CONNECTION BAR N141x		ECI A/S	2-0-25057 *	200878
P4-3	CONNECTION BAR N141x		ECI A/S	2-0-25057 *	200878
P5-3	CONNECTION ELEMENT	FOR M5 SCREW	ECI A/S	1-0-25860	225860

POSITION	DESCRIPTION		MANUFACTOR	TYPE	PART NO.
P6-3	CONNECTION ELEMENT	FOR M5 SCREW	ECI A/S	1-0-25860	225860
P7-3	CONNECTION ELEMENT	FOR M5 SCREW	ECI A/S	1-0-25860	225860
P8-3	CONNECTION ELEMENT	FOR M5 SCREW	ECI A/S	1-0-25860	225860
P9-3	CONNECTION ELEMENT	FOR M5 SCREW	ECI A/S	1-0-25860	225860
P10-3	CONNECTION ELEMENT	FOR M5 SCREW	ECI A/S	1-0-25860	225860
P11-3	MULTIPLUG	2x4 POLES PCB VERSION	MOLEX	39-28-1083	78.218
P12-3	CONNECTION BAR N141x		ECI A/S	2-0-25057 *	200878
P13-3	CONNECTION BAR N141x		ECI A/S	2-0-25057 *	200878
P14.3	PLUG	1/10" SIL SQ.PINS 2 POLES	AMP	0-826629-2 (0-826647-2)	78.322
P15-3	PLUG	1/10" SIL SQ.PINS 2 POLES	AMP	0-826629-2 (0-826647-2)	78.322
P16-3	PLUG	1/10" SIL SQ.PINS 2 POLES	AMP	0-826629-2 (0-826647-2)	78.322
Q1-3	TRANSISTOR AF	BC548 NPN TO-92	PHILIPS	BC548 (-A/-B/-C)	28.070
R1-3	RESISTOR MF	1k5 OHM 5% 0.33W	PHILIPS	2322 187 73152	02.476
R2-3	PRESET CERMET	1k0 OHM 10% 0.5W	BOURNS	3386P-1-102	07.886
R3-3	RESISTOR MF	22k1 OHM 1% 0.25W	PHILIPS	2322 157 12213	02.234
R4-3	RESISTOR MF	330k OHM 5% 0.4W	PHILIPS	2322 181 53334	01.262
R5-3	RESISTOR MF	5k11 OHM 1% 0.25W	PHILIPS	2322 157 15112	02.228
R6-3	RESISTOR MF	5k11 OHM 1% 0.25W	PHILIPS	2322 157 15112	02.228
R7-3	RESISTOR MF	10k OHM 5% 0.33W	PHILIPS	2322 187 73103	02.496
R8-3	RESISTOR MF	10k OHM 5% 0.33W	PHILIPS	2322 187 73103	02.496
R9-3	RESISTOR MF	10k OHM 5% 0.33W	PHILIPS	2322 187 73103	02.496
R10-3	RESISTOR MF	10k OHM 5% 0.33W	PHILIPS	2322 187 73103	02.496
R11-3	RESISTOR MF	10k OHM 5% 0.33W	PHILIPS	2322 187 73103	02.496
R12-3	RESISTOR MF	470k OHM 5% 0.33W	PHILIPS	2322 187 73474	02.536
R13-3	RESISTOR MF	1k0 OHM 5% 0.33W	PHILIPS	2322 187 73102	02.472
RE1-3	RELAY	24VDC 2SH. 2A	OMRON	G5V-2-24 VDC	21.327
RE2-3	RELAY	24VDC 2SH. 2A	OMRON	G5V-2-24 VDC	21.327
ST1-3	TERMINAL BLOCK	3 POLES 1.5mm2	PTR	AK300/3b m.MESS.SKRUER	81.026
ST2-3	TERMINAL BLOCK	3 POLES 2.5mm2	PTR	AK110/3DS m.MESS.SKRUER	81.037
ST3-3	TERMINAL BLOCK	10 POLES 1.5mm2	PTR	AK300/10b m.MESS.SKRUER	81.017
ST4-3	TERMINAL BLOCK	2 POLES 1.5mm2	PTR	AK300/2b m.MESS.SKRUER	81.023
ST5-3	TERMINAL BLOCK	2 POLES 2.5mm2	PTR	AK110/2DS m.MESS.SKRUER	81.035
ST6-3	TERMINAL BLOCK	4 POLES 2.5mm2	PTR	AK110/4DS m.MESS.SKRUER	81.038
ST7-3	TERMINAL BLOCK	6 POLES 1.5mm2	PTR	AK300/6b m.MESS.SKRUER	81.016
U1-3	DUAL OP AMP	LM358N	TEXAS	LM358P	31.100

CONNECTION BOARD	N2174 DUAL	S.P.RADIO A/S 0-0-26398	726399
------------------	------------	-------------------------	--------

POSITION	DESCRIPTION		MANUFACTOR	TYPE	PART NO.
VARIOUS	DISTANCE PIECE	Ø4.8x0.8x8mm	OJD	4,8X0,8X8 MESS.	63.106
VARIOUS	SPARE FUSES FOR CON.BOARD	CONNECTION BOARDS	S.P.RADIO	0-0-27794	727794
VARIOUS	SCREW M3x12mm PHJX-Z	DIN 7985	HFC	HFC9041 M3x12 PHJX-Z DIN 7985	86.956
-4	CONNECTION DUAL BATTERY	CHARGER (MODULE 4) N2174	ECI A/S	5-0-26447B / 4-0-26447A	626447
D6-4	DIODE POW.RECT.35A/100VDC	1N1184R/BYX52-300R	INT.RECTIFIER	1N1184R INCL.HARDWARE (1N1185R,-86R,---,-90R)	25.165
D12-4	DIODE POW.RECT.35A/100VDC	1N1184R/BYX52-300R	INT.RECTIFIER	1N1184R INCL.HARDWARE (1N1185R,-86R,---,-90R)	25.165
F3-4	FUSE	50A 11x41mm	BOSCH	1 191 017 005 DIN 72 581 - B 50	45.702
F9-4	FUSE	50A 11x41mm	BOSCH	1 191 017 005 DIN 72 581 - B 50	45.702
R1	SHUNT 80A-75mV		SIFAM	SHUNT MEDIUM CURRENT 80A-75mV	23.160

CONNECTION DUAL BATTERY CHARGER (MODULE 4) N2174	ECI A/S	5-0-26447B / 4-0-26447A	626447
--	---------	-------------------------	--------

POSITION	DESCRIPTION		MANUFACTOR	TYPE	PART NO.
VARIOUS	CONNECTION DUAL BATTERY	CHARG.(4) FOR N2174 DUAL		5-0-26447B / 1-0-26447	52.017
C1-4	CAPACITOR MKT	470nF 20% 63VDC	ERO	MKT 1826-447/06 6-G	11.188
C2-4	CAPACITOR ELECTROLYTIC	100uF -10/+50% 25VDC	ERO	EKM 00 CC 310 E G5	14.610
C3-4	CAPACITOR ELECTROLYTIC	10uF 20% 35VDC	ELNA	RJ2-35-V-100-M-T34(T58)	14.512

POSITION	DESCRIPTION		MANUFACTURER	TYPE	PART NO.
C4-4	CAPACITOR MKT	470nF 20% 63VDC	ERO	MKT 1826-447/06 6-G	11.188
C5-4	CAPACITOR ELECTROLYTIC	100uF -10/+50% 25VDC	ERO	EKM 00 CC 310 E G5	14.610
C6-4	CAPACITOR ELECTROLYTIC	10uF 20% 35VDC	ELNA	RJ2-35-V-100-M-T34(T58)	14.512
D1-4	DIODE ZENER	5.1V 5% 0.4W BZX79C5V1	PHILIPS	BZX79C5V1	26.527
D2-4	DIODE HIGH SPEED	1N4448	PHILIPS	1N4448	25.147
D3-4	DIODE HIGH SPEED	1N4448	PHILIPS	1N4448	25.147
D4-4	DIODE HIGH SPEED	1N4448	PHILIPS	1N4448	25.147
D5-4	DIODE HIGH SPEED	1N4448	PHILIPS	1N4448	25.147
D6-4	DIODE POW.RECT.35A/100VDC	1N1184R/BYX52-300R	INT.RECTIFIER	1N1184R INCL.HARDWARE (1N1185R,-86R,---,-90R)	25.165
D7-4	DIODE ZENER	5.1V 5% 0.4W BZX79C5V1	PHILIPS	BZX79C5V1	26.527
D8-4	DIODE HIGH SPEED	1N4448	PHILIPS	1N4448	25.147
D9-4	DIODE HIGH SPEED	1N4448	PHILIPS	1N4448	25.147
D10-4	DIODE HIGH SPEED	1N4448	PHILIPS	1N4448	25.147
D11-4	DIODE HIGH SPEED	1N4448	PHILIPS	1N4448	25.147
D12-4	DIODE POW.RECT.35A/100VDC	1N1184R/BYX52-300R	INT.RECTIFIER	1N1184R INCL.HARDWARE (1N1185R,-86R,---,-90R)	25.165
F1-4	FUSE	8AF 250V Ø5x20mm	LITTEL FUSE	217008.	45.561
F2-4	FUSE	8AF 250V Ø5x20mm	LITTEL FUSE	217008.	45.561
F3-4	FUSE	50A 11x41mm	BOSCH	1 191 017 005	45.702
F4-4	FUSE	2AT 250V 5x20mm	WICKMANN	DIN 72 581 - B 50 19 195 2AT	45.508
F5-4	FUSE	2AT 250V 5x20mm	WICKMANN	19 195 2AT	45.508
F6-4	FUSE	2AT 250V 5x20mm	WICKMANN	19 195 2AT	45.508
F7-4	FUSE	8AF 250V Ø5x20mm	LITTEL FUSE	217008.	45.561
F8-4	FUSE	8AF 250V Ø5x20mm	LITTEL FUSE	217008.	45.561
F9-4	FUSE	50A 11x41mm	BOSCH	1 191 017 005 DIN 72 581 - B 50	45.702
F10-4	FUSE	2AT 250V 5x20mm	WICKMANN	19 195 2AT	45.508
F11-4	FUSE	2AT 250V 5x20mm	WICKMANN	19 195 2AT	45.508
F12-4	FUSE	2AT 250V 5x20mm	WICKMANN	19 195 2AT	45.508
P1-4	CONNECTION ELEMENT	FOR M5 SCREW	ECI A/S	1-0-25860	225860
P2-4	CONNECTION ELEMENT	FOR M5 SCREW	ECI A/S	1-0-25860	225860
P3-4	MULTIPLUG	2x4 POLES PCB VERSION	MOLEX	39-28-1083	78.218
P4-4	MULTIPLUG	2x5 POLES PCB VERSION	MOLEX	39-28-1103	78.220
P5-4	CONNECTION BAR N141x		ECI A/S	2-0-25057 *	200878
P6-4	CONNECTION BAR N141x		ECI A/S	2-0-25057 *	200878
P7-4	CONNECTION ELEMENT	FOR M5 SCREW	ECI A/S	1-0-25860	225860
P8-4	CONNECTION ELEMENT	FOR M5 SCREW	ECI A/S	1-0-25860	225860
P9-4	MULTIPLUG	2x4 POLES PCB VERSION	MOLEX	39-28-1083	78.218
P10-4	MULTIPLUG	2x5 POLES PCB VERSION	MOLEX	39-28-1103	78.220
P11-4	CONNECTION BAR N141x		ECI A/S	2-0-25057 *	200878
P12-4	CONNECTION BAR N141x		ECI A/S	2-0-25057 *	200878
P13-4	PLUG	1/10" SIL SQ.PINS 2 POLES	AMP	0-826629-2 (0-826647-2)	78.322
P14-4	PLUG	1/10" SIL SQ.PINS 2 POLES	AMP	0-826629-2 (0-826647-2)	78.322
P15-4	PLUG	1/10" SIL SQ.PINS 2 POLES	AMP	0-826629-2 (0-826647-2)	78.322
P16-4	PLUG	1/10" SIL SQ.PINS 2 POLES	AMP	0-826629-2 (0-826647-2)	78.322
P17-4	PLUG	1/10" SIL SQ.PINS 2 POLES	AMP	0-826629-2 (0-826647-2)	78.322
P18-4	PLUG	1/10" SIL SQ.PINS 2 POLES	AMP	0-826629-2 (0-826647-2)	78.322
Q1-4	TRANSISTOR AF	BC548 NPN TO-92	PHILIPS	BC548 (-A/-B/-C)	28.070
Q2-4	TRANSISTOR AF	BC548 NPN TO-92	PHILIPS	BC548 (-A/-B/-C)	28.070
R1-4	RESISTOR MF	1k5 OHM 5% 0.33W	PHILIPS	2322 187 73152	02.476
R2-4	RESISTOR MF	22k1 OHM 1% 0.25W	PHILIPS	2322 157 12213	02.234
R3-4	PRESET CERMET	1k0 OHM 10% 0.5W	BOURNS	3386P-1-102	07.886
R4-4	RESISTOR MF	5k11 OHM 1% 0.25W	PHILIPS	2322 157 15112	02.228
R5-4	RESISTOR MF	5k11 OHM 1% 0.25W	PHILIPS	2322 157 15112	02.228
R6-4	RESISTOR MF	330k OHM 5% 0.4W	PHILIPS	2322 181 53334	01.262
R7-4	RESISTOR MF	10k OHM 5% 0.33W	PHILIPS	2322 187 73103	02.496
R8-4	RESISTOR MF	10k OHM 5% 0.33W	PHILIPS	2322 187 73103	02.496
R9-4	RESISTOR MF	10k OHM 5% 0.33W	PHILIPS	2322 187 73103	02.496
R10-4	RESISTOR MF	10k OHM 5% 0.33W	PHILIPS	2322 187 73103	02.496
R11-4	RESISTOR MF	470k OHM 5% 0.33W	PHILIPS	2322 187 73474	02.536
R12-4	RESISTOR MF	10k OHM 5% 0.33W	PHILIPS	2322 187 73103	02.496
R13-4	RESISTOR MF	1k0 OHM 5% 0.33W	PHILIPS	2322 187 73102	02.472
R14-4	RESISTOR MF	1k5 OHM 5% 0.33W	PHILIPS	2322 187 73152	02.476

POSITION	DESCRIPTION		MANUFACTOR	TYPE	PART NO.
R15-4	RESISTOR MF	22k1 OHM 1% 0.25W	PHILIPS	2322 157 12213	02.234
R16-4	PRESET CERMET	1k0 OHM 10% 0.5W	BOURNS	3386P-1-102	07.886
R17-4	RESISTOR MF	5k11 OHM 1% 0.25W	PHILIPS	2322 157 15112	02.228
R18-4	RESISTOR MF	5k11 OHM 1% 0.25W	PHILIPS	2322 157 15112	02.228
R19-4	RESISTOR MF	330k OHM 5% 0.4W	PHILIPS	2322 181 53334	01.262
R20-4	RESISTOR MF	10k OHM 5% 0.33W	PHILIPS	2322 187 73103	02.496
R21-4	RESISTOR MF	10k OHM 5% 0.33W	PHILIPS	2322 187 73103	02.496
R22-4	RESISTOR MF	10k OHM 5% 0.33W	PHILIPS	2322 187 73103	02.496
R23-4	RESISTOR MF	10k OHM 5% 0.33W	PHILIPS	2322 187 73103	02.496
R24-4	RESISTOR MF	470k OHM 5% 0.33W	PHILIPS	2322 187 73474	02.536
R25-4	RESISTOR MF	10k OHM 5% 0.33W	PHILIPS	2322 187 73103	02.496
R26-4	RESISTOR MF	1k0 OHM 5% 0.33W	PHILIPS	2322 187 73102	02.472
RE1-4	RELAY	24VDC 2SH. 2A	OMRON	G5V-2-24 VDC	21.327
RE2-4	RELAY	24VDC 2SH. 2A	OMRON	G5V-2-24 VDC	21.327
RE3-4	RELAY	24VDC 2SH. 2A	OMRON	G5V-2-24 VDC	21.327
RE4-4	RELAY	24VDC 2SH. 2A	OMRON	G5V-2-24 VDC	21.327
ST1-4	TERMINAL BLOCK	10 POLES 1.5mm2	PTR	AK300/10b m.MESS.SKRUER	81.017
ST2-4	TERMINAL BLOCK	2 POLES 1.5mm2	PTR	AK300/2b m.MESS.SKRUER	81.023
ST3-4	TERMINAL BLOCK	2 POLES 2.5mm2	PTR	AK110/2DS m.MESS.SKRUER	81.035
ST4-4	TERMINAL BLOCK	4 POLES 2.5mm2	PTR	AK110/4DS m.MESS.SKRUER	81.038
ST5-4	TERMINAL BLOCK	6 POLES 1.5mm2	PTR	AK300/6b m.MESS.SKRUER	81.016
ST6-4	TERMINAL BLOCK	3 POLES 2.5mm2	PTR	AK110/3DS m.MESS.SKRUER	81.037
ST7-4	TERMINAL BLOCK	10 POLES 1.5mm2	PTR	AK300/10b m.MESS.SKRUER	81.017
ST8-4	TERMINAL BLOCK	2 POLES 1.5mm2	PTR	AK300/2b m.MESS.SKRUER	81.023
ST9-4	TERMINAL BLOCK	2 POLES 2.5mm2	PTR	AK110/2DS m.MESS.SKRUER	81.035
ST10-4	TERMINAL BLOCK	4 POLES 2.5mm2	PTR	AK110/4DS m.MESS.SKRUER	81.038
ST11-4	TERMINAL BLOCK	6 POLES 1.5mm2	PTR	AK300/6b m.MESS.SKRUER	81.016
ST12-4	TERMINAL BLOCK	3 POLES 2.5mm2	PTR	AK110/3DS m.MESS.SKRUER	81.037
U1-4	DUAL OP AMP	LM358N	TEXAS	LM358P	31.100
U2-4	DUAL OP AMP	LM358N	TEXAS	LM358P	31.100

REMOTE CONTROL UNIT H2180 FOR N2174 BATTERY CHARGER	S.P.RADIO A/S H2180	802180
--	----------------------------	---------------

POSITION	DESCRIPTION		MANUFACTOR	TYPE	PART NO.
D1	DIODE RECTIFIER	1N4002 100V/1A	THOMSON	1N4002 (03/04/05/06/07)	25.100
D2	DIODE RECTIFIER	1N4002 100V/1A	THOMSON	1N4002 (03/04/05/06/07)	25.100
ME1	PANEL METER	SCALED 80-0-80 AMP.	SIFAM	29WF/75-0-75mV SCALED 80/0/80A	23.136
ME2	PANEL METER	SCALED 0-40V	SIFAM	29WF/0-40V, SCALED 0-40V	23.135
P1	PLUG	6 POLES	HIRSCHMANN	973 021-100 6 pole Male for Chassis	78.311
S1	ROCKER SWITCH	DPDT ON-NONE-ON 4A/250VAC	CARLINGSWITCH	6 10 1 2 4 2 1-0-0	43.011
S2	ROCKER SWITCH	DPDT ON-NONE-ON 4A/250VAC	CARLINGSWITCH	6 10 1 2 4 2 1-0-0	43.011

HF SSB H2182	FUSE BOX, 30 Amps.	S.P.RADIO A/S HF SSB H2182	802182
---------------------	---------------------------	-----------------------------------	---------------

POSITION	DESCRIPTION		MANUFACTOR	TYPE	PART NO.
VARIOUS	CABINET,FUSE BOX H2182/3		S.P.RADIO A/S	0-0-28250	728250
VARIOUS	FUSE ARRANGEMENT H2182		S.P.RADIO A/S	0-0-28252	728252

FUSE ARRANGEMENT H2182	S.P.RADIO A/S 0-0-28252	728252
-------------------------------	--------------------------------	---------------

POSITION	DESCRIPTION		MANUFACTOR	TYPE	PART NO.
F1	CIRCUIT BREAKER FUSED	2 POLES 440VAC-110VDC/63A	GE/VYNCKIER	V/099-006263	43.215
F2	CIRCUIT BREAKER FUSED	2 POLES 440VAC-110VDC/63A	GE/VYNCKIER	V/099-006263	43.215
F3	CIRCUIT BREAKER FUSED	1 POLE 440VAC-48VDC/10A	GE/VYNCKIER	V/099-004110	43.203
F4	CIRCUIT BREAKER FUSED	1 POLE 440VAC-48VDC/2A	GE/VYNCKIER	V/099-004102	43.201
F5	CIRCUIT BREAKER FUSED	1 POLE 440VAC-48VDC/10A	GE/VYNCKIER	V/099-004110	43.203
F6	CIRCUIT BREAKER FUSED	1 POLE 440VAC-48VDC/10A	GE/VYNCKIER	V/099-004110	43.203
F7	CIRCUIT BREAKER FUSED	1 POLE 440VAC-48VDC/32A	GE/VYNCKIER	V/099-004132	43.205

POSITION	DESCRIPTION		MANUFACTOR	TYPE	PART NO.
F8	FUSE	5x25mm 10A M 250V	ELU	17252510000	45.580
F9	FUSE	5x25mm 10A M 250V	ELU	17252510000	45.580
F10	FUSE	5x25mm 10A M 250V	ELU	17252510000	45.580
R1	SHUNT 80A-75mV		SIFAM	SHUNT MEDIUM CURRENT 80A-75mV	23.160
ST1	THROUGH TERMINAL BLOCK	16mm2	WEIDMULLER	SAK16/35 - 3806.6	81.061
ST2	THROUGH TERMINAL BLOCK	16mm2	WEIDMULLER	SAK16/35 - 3806.6	81.061
ST3	THROUGH TERMINAL BLOCK	16mm2	WEIDMULLER	SAK16/35 - 3806.6	81.061
ST4	THROUGH TERMINAL BLOCK	16mm2	WEIDMULLER	SAK16/35 - 3806.6	81.061
ST5	THROUGH TERMINAL BLOCK		WEIDMULLER	SAK2,5/35 3804.6	81.049
ST6	THROUGH TERMINAL BLOCK		WEIDMULLER	SAK2,5/35 3804.6	81.049

TECHNICAL MANUAL FOR TX CONTROL UNIT
(PART NO. 726391)

CONTENTS

1	GENERAL INFORMATION	
1.1	INTRODUCTION	1-1
1.2	PRINCIPLE OF OPERATION AND BLOCK DIAGRAM	1-1
2	INSTALLATION	
2.1	ELECTRICAL CONNECTION AND ASSEMBLING	2-1
3	SERVICE	
3.1	ALIGNMENT INSTRUCTIONS	
3.2	PROPOSAL FOR NECESSARY MEASURING INSTRUMENTS	3-1
3.3	TROUBLE SHOOTING	3-1
3.4	PERFORMANCE CHECK	3-4
3.5	ADJUSTMENT PROCEDURE.	3-10
3.6	NECESSARY ADJUSTMENT AFTER REPAIR	3-11
4	MECHANICAL DESCRIPTION	
4.1	MECHANICAL ASSEMBLING / DISASSEMBLING AND UNITS LOCATION	4-1
5	CIRCUIT DESCRIPTION AND SCHEMATIC DIAGRAMS	
5.1	FILTER 1 (MODULE 1) PART NO. 726401	5-1
5.2	FILTER 2 (MODULE 2) PART NO. 726402	5-1
5.3	FILTER 3 (MODULE 3) PART NO. 726403	5-1
5.4	FILTER 4 (MODULE 4) PART NO. 726404	5-1
5.5	FILTER 5 (MODULE 5) PART NO. 726405	5-1
5.6	FILTER 6 (MODULE 6) PART NO. 726406	5-2
5.7	FILTER SWITCH UNIT (MODULE 7) PART NO. 627147	5-5
5.8	TX-PROCESSOR (MODULE 8) PART NO. 626408	5-9
5.9	POWER SUPPLY (MODULE 9) PART NO. 626409	5-23
5.10	AF-AMPLIFIER (MODULE 10) PART NO. 626410	5-27
6	PARTS LISTS	

CONTENTS

1	GENERAL INFORMATION	1-1
1.1	INTRODUCTION	1-1
1.2	PRINCIPLE OF OPERATION AND BLOCK DIAGRAM	1-1

GRØN SIDE

1 GENERAL INFORMATION

1.1 INTRODUCTION

This section gives you all necessary information to make service of this unit down to component level.

1.2 PRINCIPLE OF OPERATION AND BLOCK DIAGRAM

The TX control unit consists of the following modules:

FILTER 1	(MODULE 1)
FILTER 2	(MODULE 2)
FILTER 3	(MODULE 3)
FILTER 4	(MODULE 4)
FILTER 5	(MODULE 5)
FILTER 6	(MODULE 6)
FILTER SWITCH	(MODULE 7)
TX PROCESSOR	(MODULE 8)
POWER SUPPLY	(MODULE 9)
AF AMPLIFIER	(MODULE 10)

The block diagram of the modules are shown on the next pages with a short function description.

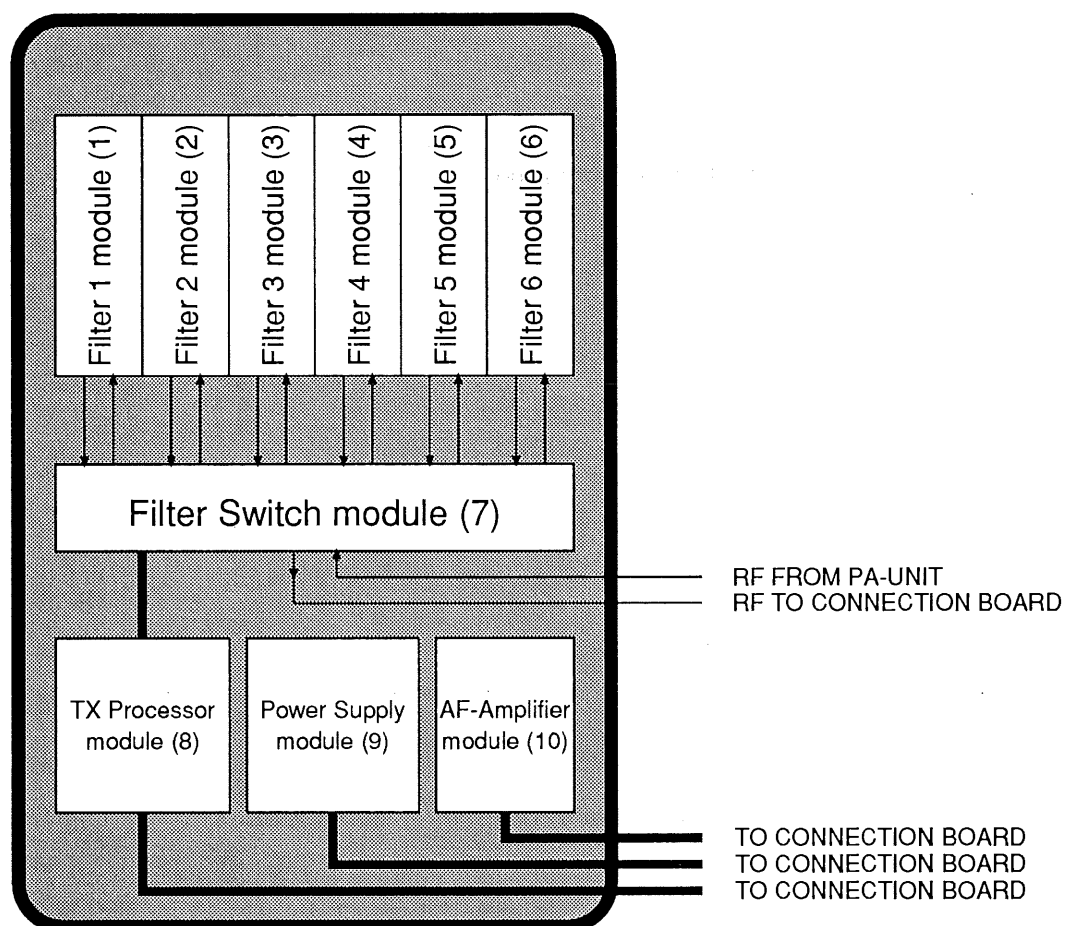

28329

FILTER 1 - 6 (MODULE 1 - 6)

The filters are all constructed in the same way.

The RF from the power unit/combiner unit is fed into the lowpass and highpass filter.

The fundamental frequency passes the lowpass filter to the output. The harmonic frequencies are reflected by the lowpass filter, but passes through the highpass filter, which are terminated with a 100 ohm resistor. This gives a correct load impedance for the power amplifier for the whole frequency range of the filter.

FILTER 1 TO 6

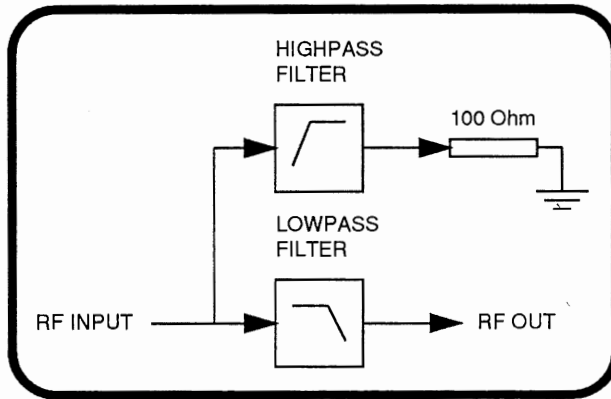

28330

FILTER SWITCH (MODULE 7)

The filter switch takes care of switching in the correct filters and selecting the dummy load. It also contains the standing wave detector which is used for protection of the power amplifier and tuning of the aerial coupler.

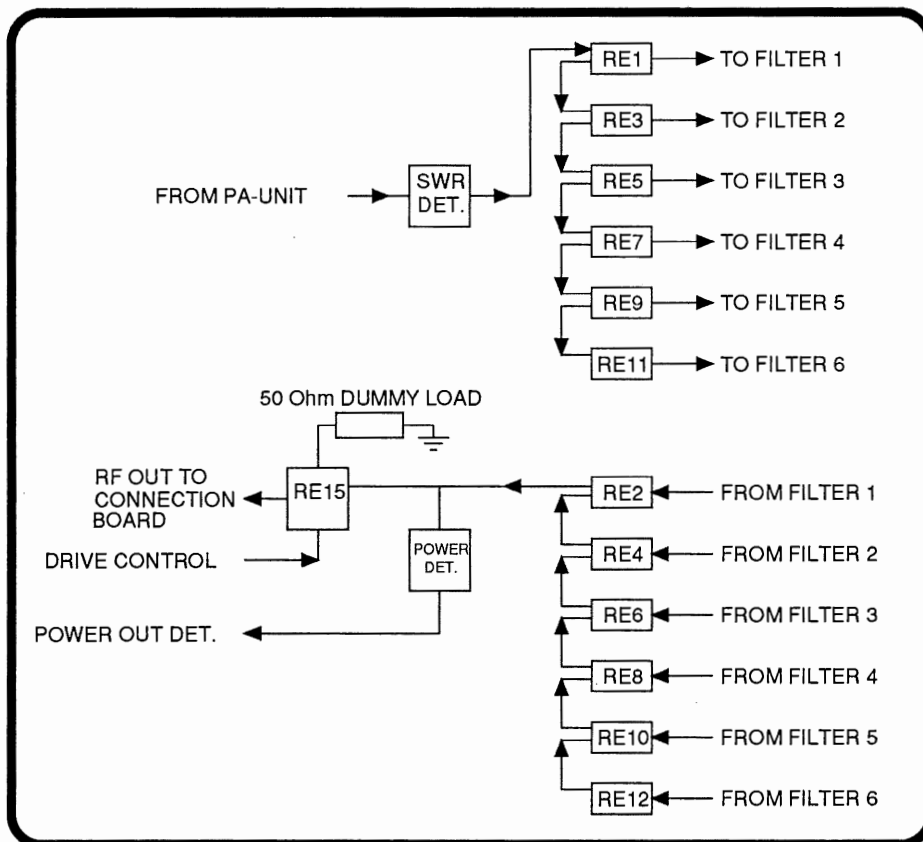

28331

TX PROCESSOR (MODULE 8)

The processor controls the power supplies, the power amplifiers, output filters, aerial coupler AT2112, and the communication with RE2100.

During rise, the TX processor tests the system and turns on the power supplies, respectively.

From RE2100, the TX processor receives information about frequency and receive/transmit mode. The TX processor gives information to RE2100 about tuning/tune ready and attenuated setting.

During tune-up, the TX processor controls the aerial coupler. The aerial coupler tunes for best standing wave ratio measured with the directional coupler on the output filter module.

During transmit, the TX processor checks the temperature of the PA transistors, power from each PA module, AC supply and standing wave ratio. From these data, the TX processor calculates the max. permissible power and then sends this information to the RE2100, where the processor unit sets the attenuation in the exciter unit to the values.

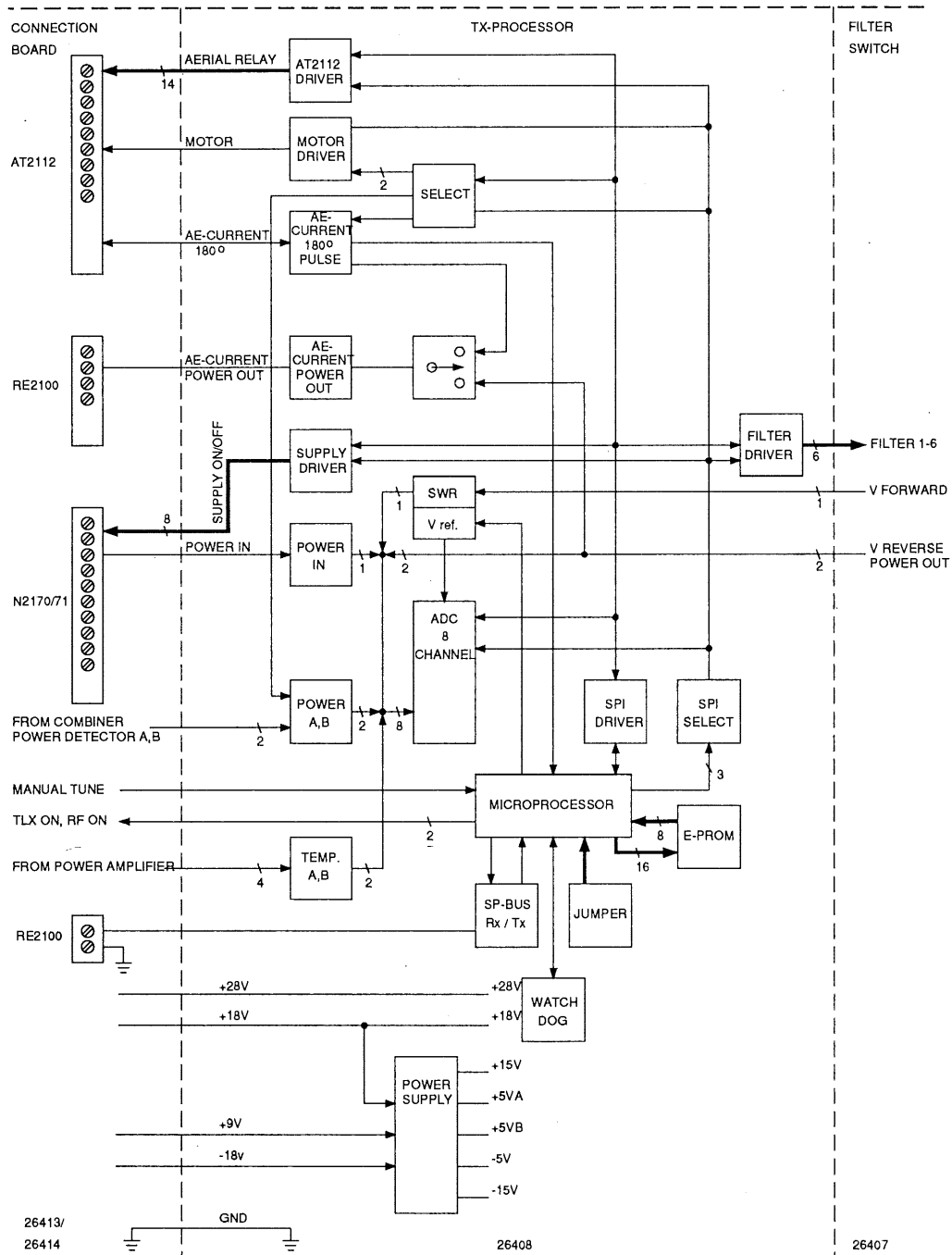

POWER SUPPLY (MODULE 9)

The power supply is supplying the RE2100 and the TX processor (module 8), the filter switch (module 7), the combiner unit (only in 1200W version) and the power supply N2170 or N2171. The power supply can be supplied from 24V battery and/or from 220V AC via the transformer and the rectifier.

The rectifier is followed by the input filter. After the input filter, the on/off relay is situated. Then follows the switch control and the push-pull switch transistors. The switch control has two external regulations loops, one for current and one for voltage regulation.

The power supply has three output voltages $\pm 19V$ and 9.5V.

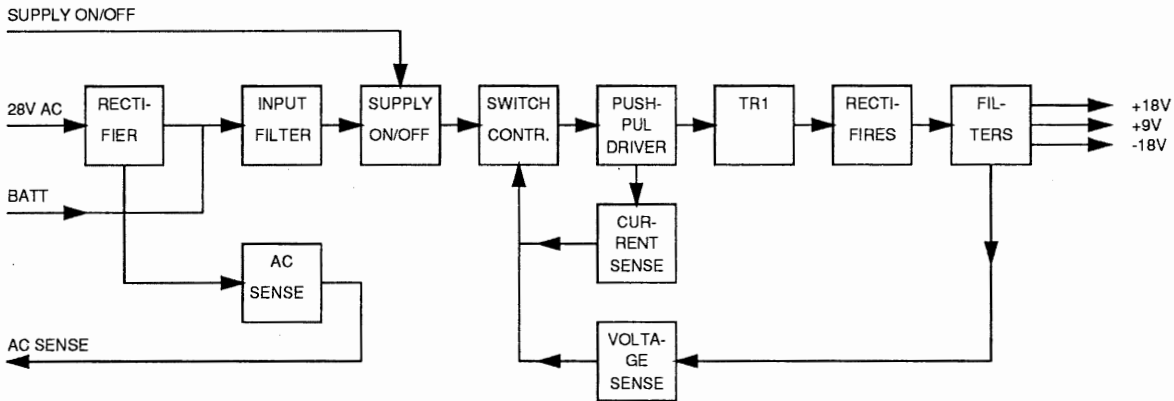

28335

AF AMPLIFIER (MODULE 10)

The audio amplifier amplifies the audio, which comes from the RE2100. At the input is a transformer which gives a balanced input. This is done to avoid noise to get into the amplifier.

The mute relay in the output is activated when transmitting.

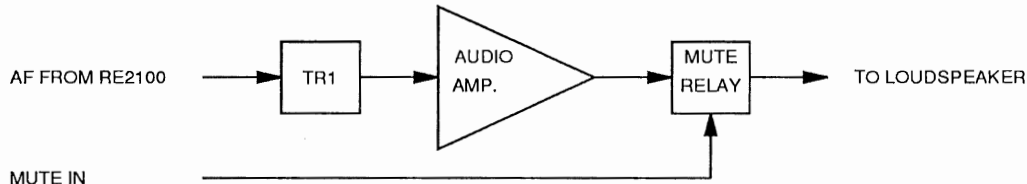

28336

CONTENTS

2	INSTALLATION	2-1
2.1	ELECTRICAL CONNECTION AND ASSEMBLING	2-1

GRØN SIDE

2 INSTALLATION

2.1 ELECTRICAL CONNECTION AND ASSEMBLING

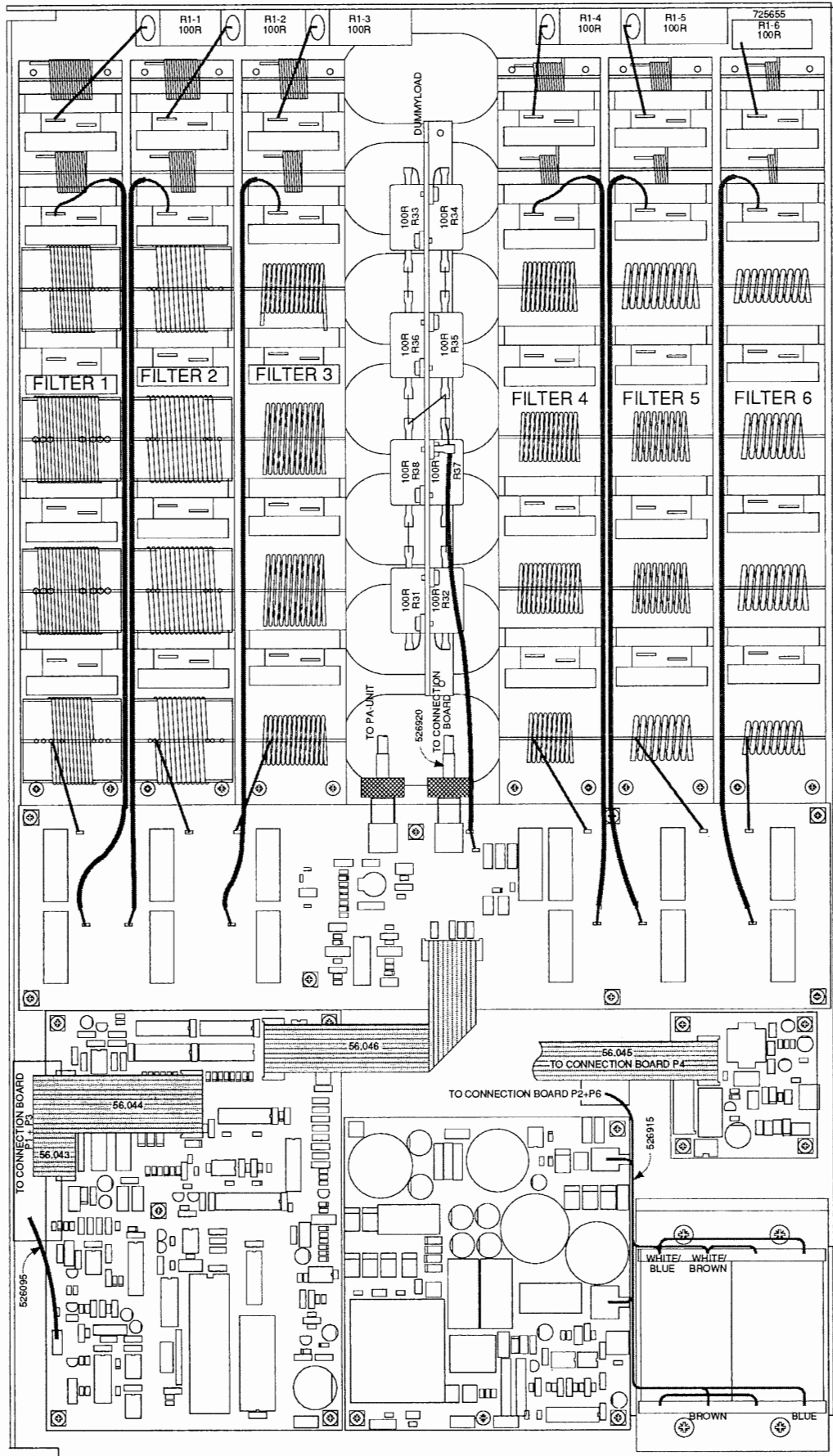

CONTENTS

3	SERVICE	
3.1	ALIGNMENT INSTRUCTIONS	3-1
3.2	PROPOSAL FOR NECESSARY MEASURING INSTRUMENTS	3-1
3.3	TROUBLE SHOOTING	3-1
3.4	PERFORMANCE CHECK	3-4
3.5	ADJUSTMENT PROCEDURE.	3-10
3.6	NECESSARY ADJUSTMENT AFTER REPAIR	3-11

3 SERVICE

3.1 ALIGNMENT INSTRUCTIONS

INTRODUCTION

The measuring values indicated in chapter 5. CIRCUIT DESCRIPTION AND SCHEMATIC DIAGRAMS are typical values and as indicated it will be necessary to use instruments in absolute conformity with the below list:

3.2 PROPOSAL FOR NECESSARY MEASURING INSTRUMENTS

Tone Generator type PM5107	PHILIPS
Electronic Multimeter type PM2505	PHILIPS
RF Directional Wattmeter model 43	BIRD
Oscilloscope type PM321	PHILIPS
Dummy load 50 ohm/600W	
Power supply 21-32V,	50A (600W transmitter)
	100A (1200W transmitter)

3.3 TROUBLE SHOOTING

In this section you will find guidelines which will enable you to find the faulty module within this unit. In this section all important in/out-puts will be described.

3.3.1 MODULE 1

Test frequency:	2000 KHz
Test instrument:	Oscilloscope with 10:1 probe.
Mode:	Press <TX> - <TUNE>.
Typical input voltage =	200 Vpeak
Typical output voltage =	200 Vpeak
Maximum passband attenuation	1dB
Maximum attenuation at 2.4 MHz	1dB

If the filter get's defective following error codes is expected 73, 78 and 80.

3.3.2 MODULE 2

Test frequency:	3500 KHz
Test instrument:	Oscilloscope with 10:1 probe.
Mode:	Press <TX> - <TUNE>.
Typical input voltage =	200 Vpeak
Typical output voltage =	200 Vpeak
Maximum passband attenuation	1dB
Maximum attenuation at 3.9 Mhz	1dB

If the filter get's defective following error codes is expected 73, 78 and 80.

3.3.3 MODULE 3

Test frequency:	6200 KHz
Test instrument:	Oscilloscope with 10:1 probe.
Mode:	Press <TX> - <TUNE>.
Typical input voltage =	230 Vpeak 600W, 350Vpeak 1200W
Typical output voltage =	230 Vpeak 600W, 350Vpeak 1200W
Maximum passband attenuation	1dB
Maximum attenuation at 6.4 MHz	1dB

If the filter gets defective following error codes is expected 73, 78 and 80.

3.3.4 MODULE 4

Test frequency:	8200 KHz
Test instrument:	Oscilloscope with 10:1 probe.
Mode:	Press <TX> - <TUNE>.
Typical input voltage =	220 Vpeak 600W, 350Vpeak 1200W
Typical output voltage =	220 Vpeak 600W, 350Vpeak 1200W
Maximum passband attenuation	1dB
Maximum attenuation at 10.4 MHz	1dB

If the filter gets defective following error codes is expected 73, 78 and 80.

3.3.5 MODULE 5

Test frequency:	16400 KHz
Test instrument:	Oscilloscope with 10:1 probe.
Mode:	Press <TX> - <TUNE>.
Typical input voltage =	220 Vpeak 600W, 300Vpeak 1200W
Typical output voltage =	220 Vpeak 600W, 300Vpeak 1200W
Maximum passband attenuation	1dB
Maximum attenuation at 16.9 MHz	1dB

If the filter gets defective following error codes is expected 73, 78 and 80.

3.3.6 MODULE 6

Test frequency:	25000 KHz
Test instrument:	Oscilloscope with 10:1 probe.
Mode:	Press <TX> - <TUNE>.
Typical input voltage =	220 Vpeak 600W, 300Vpeak 1200W
Typical output voltage =	220 Vpeak 600W, 300Vpeak 1200W
Maximum passband attenuation	1dB
Maximum attenuation at 28 MHz	1dB

If the filter gets defective following error codes is expected 73, 78 and 80.

3.3.7 MODULE 7

For location of test points please see the diagram in chapter 5.7.

3.3.7.1 RELAYS

You can check each relay, by selecting service programme SP-38-1 to 8 (see part I section 3.7)

3.3.7.2 SWR DETECTOR

When transmitting (frequency <4MHz) TP1 $V_{\text{forw}} = 8.2 \text{ V}$ and TP2 $V_{\text{refl}} = 1.2 \text{ V}$ typical.
In stand by TP1 $V_{\text{forw}} = 80\text{mV}$ and TP2 $V_{\text{refl}} = 80\text{mV}$.

3.3.8 TROUBLE SHOOTING TX-PROCESSOR (8).

Motor 'error 70'

The error may be one of following possibilities:

A: If the tune motor MO1 starts running immediately after the RE2100 has been switched on then check:

- Check the AE/180° pulse at ST5 pin 16, on the connection board (14) in T2131/35.
- If the level is high, approx. 15V, the error is probably in the aerial coupler AT2112.
Then:
- Check the AE/180° pulse connection to AT2112.
- Check the light in the optocoupler OC1 on the aerial current detector (1) in AT2112. This may be done by measuring the voltage across the resistor R3 in the aerial current detector (1).
If the level is low:
- The error is probably in the T2131/35:
- Check the AE/180° pulse connection from the connection board (14) P1 pin 15 to TX-processor (8) P3 pin 15 in T2131/35.

b: If the tune motor MO1 in AT2112 does **not** start immediately after the RE2100 has been switched on:

- Check the voltage at ST5 pin 15 on the connection board (14) (chassis as -), when RE2100 is switched on this voltage should be approx. 18V.
- If the 18V is ok then the error is probably in AT2112 then:
- Check the connection to the tune motor MO1 in AT2112, and the connection from the connection board (14) to AT2112.
- If the 18V is **not** present then the error is probably in T2131/35:
- Check the connection from the connection board (14) P1 pin 16 to TX-processor (8) P3 pin 16.

3.3.9 POWER SUPPLY (9)

3.3.9.1 INPUT SUPPLY VOLTAGE 24V DC

Check the voltage between P1 pin 1 and pin 2, must be 21V to 32V.
Input supply voltage 220V/110V AC.
Check the voltage between P1 pin 3 and 4, it must be 27V to 33V AC.

3.3.9.2 OUTPUT VOLTAGES:

Check the voltage at P2 on the following pins with chassis as reference.

Pin 1	0V when AC 5V when DC
Pin 2	0V
Pin 3	0V with -BATT as reference
Pin 4	+9V +/- 0.8V
Pin 5	+19V +/- 0.8V
Pin 6	-19V +/- 0.8V

3.3.10 AF-AMPLIFIER (10)

For location of test points please see the diagram in chapter 5.10.

3.3.10.1 CHECK OF DC VOLTAGES

TP1	18V in receive mode 0V in transmit mode
TP2	28V +/- 2V
TP3	14V +/- 2V
TP4	0V
TP6	18V

3.3.10.2 CHECK OF AC VOLTAGES

Tune the RE2100 to a station and adjust the volume control on RE2100 so you get 600 mV at TP3. Now the voltage at TP3 and TP4 must be 6V and without distortion.

3.4 PERFORMANCE CHECK

All tests are with an RE2100 connected, and all incoming power supplies must be accurate.

In the subsections in this section is referred to the following test setup mode.

- Mode 1: Standby. Receive mode, with aerial connected. The service strap in the RE2100 must be in.
- Mode 2: 50 Ohm dummy load connected to the output of T2131/35. Jumper 5 is inserted into plug P02/5 in the Tx-processor (8) in the T2131/35. The service strap in the RE2100 must be in.
- Mode 3: 50 Ohm dummy load connected to the output of the AT2112.

3.4.1 PERFORMANCE CHECK FILTER (1)

3.4.2 PERFORMANCE CHECK FILTER (2)

3.4.3 PERFORMANCE CHECK FILTER (3)

3.4.4 PERFORMANCE CHECK FILTER (4)

3.4.5 PERFORMANCE CHECK FILTER (5)

3.4.6 PERFORMANCE CHECK FILTER (6)

3.4.7 PERFORMANCE CHECK FILTER SWITCH (7)

Check that all input and output voltages is within the limits given in paragraph 3.3.1 to 3.3.10.

3.4.8 PERFORMANCE CHECK TX-PROCESSOR (8)

3.4.8.1 INCOMING VOLTAGES

Measured with voltmeter Test setup Mode 1.

<u>Incoming:</u>	<u>Pin</u>	<u>Plug</u>	<u>Meas. ref</u>
GND	27,28,29,30	5	
+9 Volt	3	5	GND
+18 Volt	2	5	GND
-18 Volt	4	5	GND
+28 Volt	14,15	5	GND

3.4.8.2 INTERNAL POWER SUPPLY

Reference voltage. Test setup: Mode 1.

- A. Connect a Voltmeter to pin 3 on U25, (MC7805). Voltage is +5.0 Volt +/- 0.2 Volt
- B. Connect a Voltmeter to pin 3 on U26, (MC7805). Voltage is +5.0 Volt +/- 0.2 Volt
- C. Connect a Voltmeter to pin 3 on U27, (MC7815). Voltage is +15.0 Volt +/- 0.6 Volt
- D. Connect a Voltmeter to pin 3 on U28, (MC79L15). Voltage is -15.0 Volt +/- 1.2 Volt
- E. Connect a Voltmeter to pin 3 on U29, (MC7905). Voltage is -5.0 Volt +/- 0.2 Volt
- F. Connect a Voltmeter to pin 8 on U15, (MC1458). Voltage is +28.0 Volt +/- 2.0 Volt

3.4.8.3 A/D CONVERTER

Reference voltage. Test setup: Mode 1.

- A. Connect a Voltmeter to pin 13 on U23, (4053). Voltage is +2.5 Volt +/- 1.5%
- B. Connect a Voltmeter to pin 7 on U16, (TL072). Voltage is +5.0 Volt +/- 1.7%

POWER IN measuring. Test setup: Mode 2.

- A. Enter SP-29.
Connect a Voltmeter to pin 3 on U16, (TL072). POWER IN voltage should be approx. 1.4 Volt DC
Leave SP-29 by entering the 'ENT' key
- B. Enter SP-22-1.
Compare the displayed POWER IN to the measured. Maximum deviation from the measured is +/-5%

POWER DET. A measuring. (1200 Watt only). Test setup: Mode 2.

- A. Enter SP-29.
Connect a Voltmeter to pin 6 on U13, (ADC0838). POWER DET A voltage should be approx. 1. Volt DC
Leave SP-29 by entering the 'ENT' key
- B. Enter SP-22-2.
Multiply the measured voltage with 3 and compare with the displayed POWER DET A.
Maximum deviation from the measured is +/-5%

POWER DET. B measuring. (1200 Watt only). Test setup: Mode 2.

- A. Enter SP-29.
Connect a Voltmeter to pin 7 on U13, (ADC0838). POWER DET A voltage should be approx. 1. Volt DC
Leave SP-29 by entering the 'ENT' key
- B. Enter SP-22-3.
Multiply the measured voltage with 3 and compare with the displayed POWER DET B.
Maximum deviation from the measured is +/-5%

VF (Vforward) measuring. Test setup: Mode 2.

- A. Enter SP-29.
Connect a Voltmeter to the upper end of R56, (3K92).
VF voltage should be approx. 6 Volt DC (600Watt)
VF voltage should be approx. 8 Volt DC (1200Watt)
Leave SP-29 by entering the 'ENT' key
- B. Enter SP-22-4.
Compare the displayed VF to the measured. Maximum deviation from the measured is +/-5%

POWER OUT measuring. Test setup: Mode 2.

- A. Enter SP-29.
Connect a Voltmeter to the upper end of R58, (3K92).
Power out voltage should be approx. 2.3 Volt DC (600 Watt)
Power out voltage should be approx. 3.3 Volt DC (1200 Watt)
Leave SP-29 by entering the 'ENT' key
- B. Enter SP-22-1.
Compare the displayed POWER OUT to the measured. Maximum deviation from the measured is +/-5%

SWR measuring. Test setup: Mode 2.

- A. Enter SP-29.
Connect a Voltmeter to the upper end of R56,(3K92) VF (Vforward) voltage should be 6-8 Volt DC
- B. Connect a Voltmeter to the upper end of R65,(3K92) VR (Vreverse) voltage should be approx. 0.5-1.2 Volt DC
Leave SP-29 by entering the 'ENT' key
- C. Calculate the SWR.

$$\text{SWR} = \frac{\text{Vforward} + \text{Vreverse}}{\text{Vforward} - \text{Vreverse}}$$

- D. Enter SP-23-0
Compare the displayed SWR to the calculated.
Maximum deviation from the calculated is +12%/-5%

Temperature measuring. Test setup: Mode 1.

Temperature in POWER AMPLIFIER A

- A. Disconnect the P5 on the Connection board (14). This is the cable to the temperature sensor R64 on the Power Amplifier (11).
Connect a resistor on 2 Kohm on the P5 between pin 10 and 11 Power Supply(4).
- B. Connect a Voltmeter to the lower end of R60,(8K2). Voltage is 2.5 Volt +/-1.7% +/- tolerances on the 2 Kohm resistor.
- C. Calculate an adctemp:

$$\text{adctemp} = \frac{\text{Measured voltage} * 255}{5.0 \text{ Volt}}$$

- D. Enter SP-21-1. Multiply the displayed result by 10.
Compare to the calculated adctemp. Maximum deviation is +/- 2. Temperature in POWER AMPLIFIER B (1200 Watt only).

- A. Disconnect the P5 on the Connection board (14). This is the cable to the temperature sensor R64 on the Power Amplifier (11).
Connect a resistor on 2 Kohm on the P5 between Power Supply(4).
- B. Connect a Voltmeter to the lower end of R60,(8K2). Voltage is 2.5 Volt +/-1.7% +/- tolerances on the 2 Kohm resistor.
- C. Calculate an adctemp:

$$\text{adctemp} = \frac{\text{Measured voltage} * 255}{5.0 \text{ Volt}}$$

- D. Enter SP-21-1. Multiply the displayed result by 10.
Compare to the calculated adctemp. Maximum deviation is +/- 2.

3.4.8.4 AC SENSE

Test setup: Mode 2.

- A. Connect a voltmeter to P5 pin 24
 IF 220 volt ac is present: The voltage is < 0.1 volt.
 IF 220 volt ac is NOT present: The voltage is > 4.5 volt.

3.4.8.5 OUTPUT FILTER MODULE DRIVERS

RX/TX CONTROL relay driver

Test setup: Mode 1, or Test setup: Mode 2.

- A. Enter SP-38-8 Connect the voltmeter to U21 pin 12. Voltage is < 1.1 Volt
 Leave SP-38-0 by entering 'ENT'

DRIVE CONTROL relay driver

- A. Enter SP-38-7 Connect the voltmeter to U21 pin 16 Voltage is < 1.1 Volt
 Leave SP-38-0 by entering 'ENT'

OUTPUT FILTER relay drivers.

Each of the six drivers control two relays for switching in the lowpass filters.

A. Enter SP-38-[1-6]

Driver	Frequency range	SP-38-X<ENT>	U	pin
Filter 1	1.6 - 2.399 Mhz	38-1	21	14
Filter 2	2.4 - 3.899 Mhz	38-2	21	15
Filter 3	3.9 - 6.399 Mhz	38-3	21	13
Filter 4	6.4 - 10.399 Mhz	38-4	21	11
Filter 5	10.4 - 16.899 Mhz	38-5	14	12
Filter 6	16.9 - 28.000 Mhz	38-6	21	10

- B. Connect the voltmeter to the specific pin
 Voltage is < 1.1 Volt

- C. Enter SP-38-0 <ENT>

3.4.8.6 RF ON

Test setup: Mode 1.

- A. Connect a voltmeter to the collector of Q5 or at P5 pin 5.
 B. Key the transmitter: Voltage is < 0.8 Volt

3.4.8.7 TELEX ON

Test setup: Mode 1.

- A. Connect a voltmeter to the collector of Q4 or at P5 pin 6.
 B. Select 'Telex mode' on the RE2100
 C. Set 'RF ON' to on by applying a voltage to the external 'RF ON', pin 5 and pin 6 is ST07 on the Connection Board (14).
 For example +18 volt from ST06 pin 4 to ST03 pin 7 and GND from ST08 pin 8 to ST07 pin 5.
 D. Voltage is < 0.8 Volt

3.4.8.8 ANTENNA COUPLER AT2112 DRIVERS

Test setup: Mode 1.

- A. Each of the 14 drivers control one relays in the AT2112 and there is a service program for each of the drivers.

Driver	SP-XX-X	U	Pin
Control 1	30-1	18	12
Control 2	30-2	18	11
Control 3	30-3	20	17
Control 4	30-4	18	13
Control 5	30-5	18	14
Control 6	30-6	20	16
Control 7	30-7	18	15
Control 8	30-8	20	15
Control 9	30-9	18	16
Control 10	31-0	20	14
Control 11	31-1	18	17
AREAL relay	31-2	20	12,13
RX/TX	31-3	18	18
RX < 4MHz	31-4	20	11

- B. Connect the voltmeter to the specific pin. The voltage > 26.0 Volt.
- C. Enter SP 30-0 <ENT>

3.4.8.9 POWER SUPPLY CONTROL DRIVERS.

Test setup: Mode 1

- A. Each of the 8 drivers control one power supply, and there is a service program for each power supply +28 and +42 Volt.

Driver		SP-XX-X	U	Pin
28V,42V	(A) AC	34-1	22	10,11
28V,42V	(B) AC	34-2	22	12,13
28V,42V	(A) DC	34-3	22	14,15
28V	(B) DC	34-4	22	16
42V	(B) DC	34-4	14	11

- B. Connect the voltmeter to the specific pin . The voltage > 3.0 Volt.
- C. Enter SP 34-0 <ENT>

3.4.8.10 AE/POWER CONDITIONING AE-CURRENT.

Test setup: Mode 1.

- A. Connect a voltmeter to U06 pin 7 or at ST6 pin 2 on the Connection Board (14).
- B. Disconnect the wire at pin 3 at ST1 on the Connection Board (6) and connect a variable power supply instead with a 1Kohm in series.
- C. Vary the power supply and check the voltmeter according the table below:

Vin:	Vout:
0.0 V	0.87 V
5.0 V	4.27 V
10.0 V	7.77 V
15.0 V	8.00 V
18.5 V	9.80 V

POWER OUT

Test setup: Mode 1.

- A. Insert jumper 5 in the Tx-processor (8).
- B. Switch off/on the RE2100
- C. Connect a voltmeter to U06 pin 7 or at ST6 pin 2 on the Connection Board (14).
- D. Key the transmitter and modulate. Read the voltmeter. Voltage follows the modulation.
- G. Remove the jumper.

3.4.8.11 EEPROM's.

- A. See Service Programme SP-24-0.

3.4.8.12 SP-BUS

Test setup: Mode 1.

- A. Ensure that exactly two termination jumpers are inserted in two of the Units connected to the SP Bus.
- B. Switch on the power on the RE2100.
If 'Error 20' is N O T displayed the SP Bus working.
If 'Error 20' appears on the RE2100 then the RE2100 cannot establish the communication link to the T2131/35.
- C. Check the cable connection between the RE2100 and the Tx-processor (8) in the T2131/35.
- D. Ensure that jumper 1 (the upper) is removed on Tx-Processor (8) .

Receiver.

Test setup: Mode 1.

- A. Remove the SP Bus cable from J01 on the Tx-Processor (8).
- B. Connect an oscilloscope.
Ch 1 to the left end of L01. (2 Volt/div)
Ch 2 at pin 11 on U05 (74HC08). (2 Volt/div)
- C. Connect a variable power supply to J01 instead of the SP Bus.
- D. Vary the voltage from +5 Volt to -5 Volt and reverse.
Check the trigger voltages = +/- 3 Volt +/-10%.

Driver.

Test setup: Mode 1.

- A. It is assumed that the received is checked and found OK.
Connect an Oscilloscope. 0.5 msec/div.
Ch 1 to U02 pin 2 as trigger+ (Driver Enable).(2 Volt/div)
Ch 2 to or with a 'T' on the SP Bus. (2 Volt/div)
- B. Let the RE2100 scan two frequencies, one below 3900 Khz, the other above 4100 Khz. Remove the antenna from RE2100.
- C. Check the output levels for the driver when the Tx-Processor 'answers' the RE2100.
Levels:
Positive: +4.0 up to 4.8 Volt.
Negative: -4.0 down to -4.8 Volt

3.4.8.13 TUNE MOTOR CONTROL

High Speed. Test setup: Mode 1.

- A. Connect a voltmeter to the cathode on D22 on the Tx-Processor (8) or at pin 15 in ST5 on the Connection Board(14) . 'MOTOR'
- B. Switch off and on the RE2100. The tune motor is then being reset at high speed. The motor runs approx. 1.5 sec. Voltage is approx 18 Volt.

Low Speed.

Test setup: Mode 1.

- A. Connect a voltmeter to the cathode on D22 on the Tx-Processor (8) or at pin 15 in ST5 on the Connection Board (14). 'MOTOR'
- B. Ensure that the AT2112 is tuned on a given frequency by entering 'Tx-tune' on the RE2100.
- C. Switch off the RE2100.
- D. Remove the rf power cable between the T2131/35 and the AT2112.
(Remove the cable from J04 on the Output Filter (2) in T2131/35).
- E. Switch on the RE2100.
- F. Key the transmitter on the handset. The tune motor runs now at least one time at low speed. The motor runs approx. 3 secs. every time. Voltage is approx 9 Volt.

3.4.8.14 MANUAL TUNE

Test setup: Mode 1.

- A. Connect a voltmeter at pin 23 on U03 (HD63B03Y)
- B. Toggle the 'Manual Tune' switch on the Connection Board (14).
High level voltage = approx. 5 Volt
Low level voltage < 0.5 Volt

3.4.8.15 MICRO PROCESSOR

Reset.

Test setup: Mode 1.

- A. Check the +5 Volt B supply at pin 1 and 2 on U03 (Max 690). Voltage = 5 Volt +/-0.25 Volt.
- B. Check the reset at pin 6 on U02 (HD63B03Y). Voltage is above the +5 Volt B minus 0.5 Volt Battery low detector.
- A. Check the +18 Volt supply at the upper end of R01 (22K1). Voltage > 17.3 Volt
- B. Check the 'Power fail output' at pin 20 on U03 (HD63B03Y). Voltage > 4.5 Volt.

Watch dog.

Test setup: Mode 1.

- A. Connect an oscilloscope to the 'Watch dog input' at pin 6 on U04 (Max 690). (0.2 sec/div and 2volt/div). Check that the level is shifted for every 0.8sec..
If it does not then the Micro processor does not execute the programme properly.

3.5 ADJUSTMENT PROCEDURE.

3.5.1 FILTER 1

No adjustments

3.5.2 FILTER 2

No adjustments

3.5.3 FILTER 3

No adjustments

3.5.4 FILTER 4

No adjustments

3.5.5 FILTER 5

No adjustments

3.5.6 FILTER 6

No adjustments

3.5.7 FILTER SWITCH (7)**3.5.7.1 ADJUSTMENT OF SWR DETECTOR**

Connect a 50 ohm dummyload (see necessary test equipment) to the output terminal ST 3 on the connection board.

Select H3E mode and 17MHz, if the transmitter is blocked in this mode , please see the information in service and identity programming of SAILOR RE2100.

Key the transmitter and adjust C5 to minium voltage at TP 2 (see chapter 5.7).

3.5.8 ADJUSTMENT PROCEDURE TX-PROCESSOR (8)

New module is delivered directly from S. P. Radio A/S :

1. Calibrate the T2131/35. Please refer to PART I chapter 3 Service Programmes, SP-25.

An exchanged module:

1. Check the EEPROM's by entering SP 24-0. Please refer to PART I chapter 3 service programmes.
2. Initialize the EEPROM's by entering SP 24-2. Please refer to PART1 chapter 3service programmes.
3. Calibrate the T2131/35. Please refer to PART1 chapter 3 service programmes.

3.5.9 POWER SUPPLY MODULE (9)**3.5.9.1 ADJUSTMENT OF SUPPLY VOLTAGE HIGH.**

Connect a variable power supply (2 amps) to -BATT and +BATT on the connection board. Adjust the power supply to 45V. Now adjust R11 so RE2100 just switches off.

3.5.10 AF AMPLIFIER MODULE 10

No adjustments.

3.6 NECESSARY ADJUSTMENT AFTER REPAIR**3.6.1 FILTER 1**

Adjustments has to be done by S.P.Radio.

3.6.2 FILTER 2

Adjustments has to be done by S.P.Radio.

3.6.3 FILTER 3

Adjustments has to be done by S.P.Radio.

3.6.4 FILTER 4

Adjustments has to be done by S.P.Radio.

3.6.5 FILTER 5

Adjustments has to be done by S.P.Radio.

3.6.6 FILTER 6

Adjustments has to be done by S.P.Radio.

3.6.7 FILTER SWITCH MODULE (7)

C5 has to be adjusted when TR 1, D2, D3, C2, C3, C4, C5 or L1 has been replaced.
When you have change components around the power out detector (D1,R2,R4,C1 or C19) you have to preform the calibration described in PART I chapter 3 service programmes (SP-25-).

3.6.8 TX-PROCESSOR (8).

If U8 or U9 has been replaced: Please refer to chapter 3.5.8 'Adjustment procedure'.

CONTENTS

4	MECHANICAL DESCRIPTION	4-1
4.1	MECHANICAL ASSEMBLING / DISASSEMBLING AND UNITS LOCATION	4-1

4 MECHANICAL DESCRIPTION

4.1 MECHANICAL ASSEMBLING / DISASSEMBLING AND UNITS LOCATION

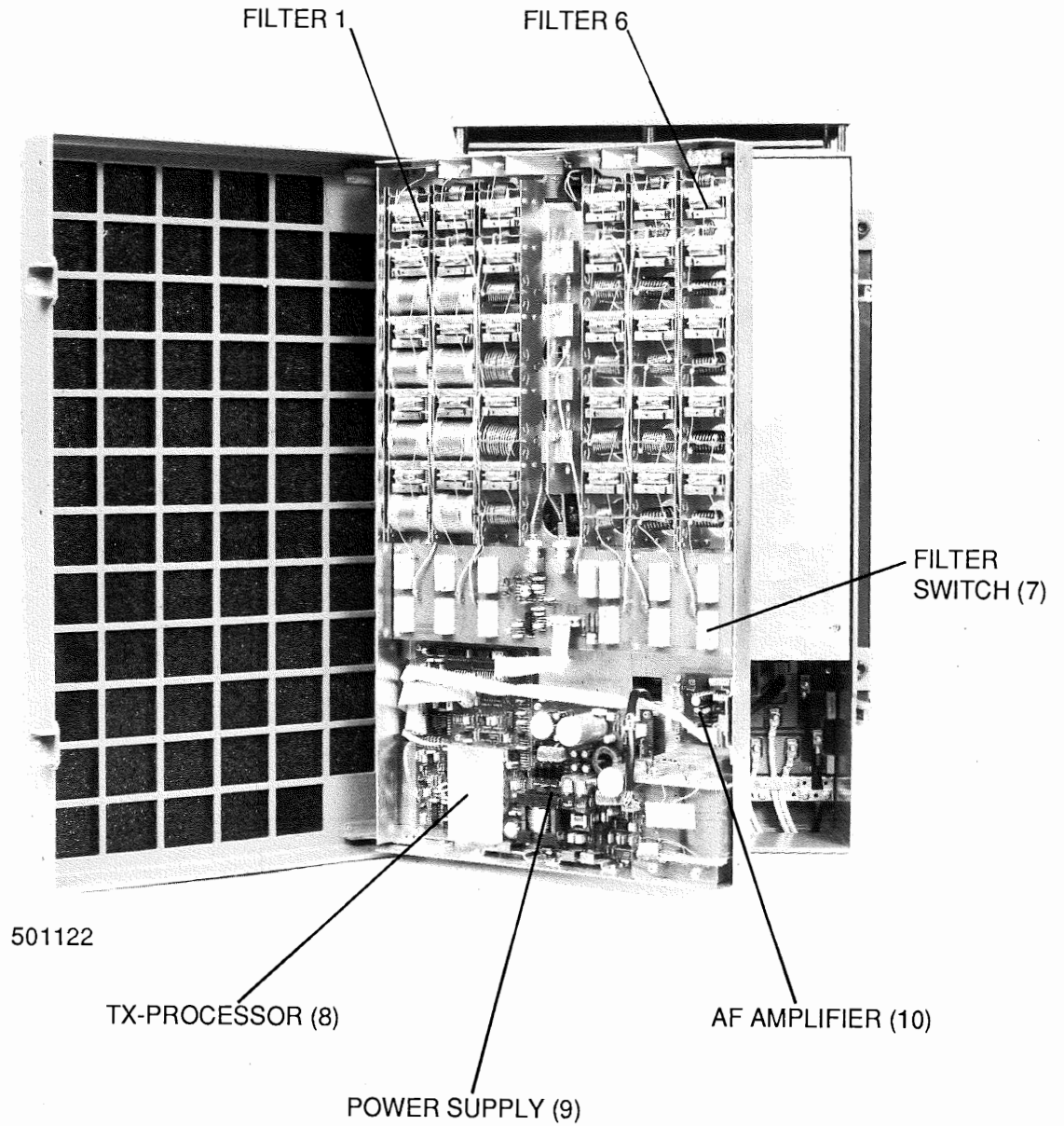

CONTENTS

5	CIRCUIT DESCRIPTION AND SCHEMATIC DIAGRAMS	
5.1	FILTER 1 (MODULE 1) PART NO. 726401	5-1
5.2	FILTER 2 (MODULE 2) PART NO. 726402	5-1
5.3	FILTER 3 (MODULE 3) PART NO. 726403	5-1
5.4	FILTER 4 (MODULE 4) PART NO. 726404	5-1
5.5	FILTER 5 (MODULE 5) PART NO. 726405	5-1
5.6	FILTER 6 (MODULE 6) PART NO. 726406	5-2
5.7	FILTER SWITCH UNIT (MODULE 7) PART NO. 627147	5-5
5.8	TX-PROCESSOR (MODULE 8) PART NO. 626408	5-9
5.9	POWER SUPPLY (MODULE 9) PART NO. 626409	5-23
5.10	AF-AMPLIFIER (MODULE 10) PART NO. 626410	5-27

5 CIRCUIT DESCRIPTION AND SCHEMATIC DIAGRAMS

5.1 FILTER 1 (MODULE 1) PART NO. 726401

The filter is constructed as a combination of a 7th order lowpass filter and a 4th order highpass filter.

The lowpass filter filters all the harmonics from the power amplifier and therefore gives an output signal with a very low content of harmonics.

The highpass filter is constructed so that the standing wave ratio of the combined filter is less than 2 above the entire frequency range for the filter plus the harmonics of the amplifier.

5.2 FILTER 2 (MODULE 2) PART NO. 726402

The filter is constructed as a combination of a 7th order lowpass filter and a 4th order highpass filter.

The lowpass filter filters all the harmonics from the power amplifier and therefore gives an output signal with a very low content of harmonics.

The highpass filter is constructed so that the standing wave ratio of the combined filter is less than 2 above the entire frequency range for the filter plus the harmonics of the amplifier.

5.3 FILTER 3 (MODULE 3) PART NO. 726403

The filter is constructed as a combination of a 7th order lowpass filter and a 4th order highpass filter.

The lowpass filter filters all the harmonics from the power amplifier and therefore gives an output signal with a very low content of harmonics.

The highpass filter is constructed so that the standing wave ratio of the combined filter is less than 2 above the entire frequency range for the filter plus the harmonics of the amplifier.

5.4 FILTER 4 (MODULE 4) PART NO. 726404

The filter is constructed as a combination of a 7th order lowpass filter and a 4th order highpass filter.

The lowpass filter filters all the harmonics from the power amplifier and therefore gives an output signal with a very low content of harmonics.

The highpass filter is constructed so that the standing wave ratio of the combined filter is less than 2 above the entire frequency range for the filter plus the harmonics of the amplifier.

5.5 FILTER 5 (MODULE 5) PART NO. 726405

The filter is constructed as a combination of a 7th order lowpass filter and a 4th order highpass filter.

The lowpass filter filters all the harmonics from the power amplifier and therefore gives an output signal with a very low content of harmonics.

The highpass filter is constructed so that the standing wave ratio of the combined filter is less than 2 above the entire frequency range for the filter plus the harmonics of the amplifier.

5.6 FILTER 6 (MODULE 6) PART NO. 726406

The filter is constructed as a combination of a 7th order lowpass filter and a 4th order highpass filter.

The lowpass filter filters all the harmonics from the power amplifier and therefore gives an output signal with a very low content of harmonics.

The highpass filter is constructed so that the standing wave ratio of the combined filter is less than 2 above the entire frequency range for the filter plus the harmonics of the amplifier.

COMPONENT LOCATION LP-FILTERS MODULE 1-6

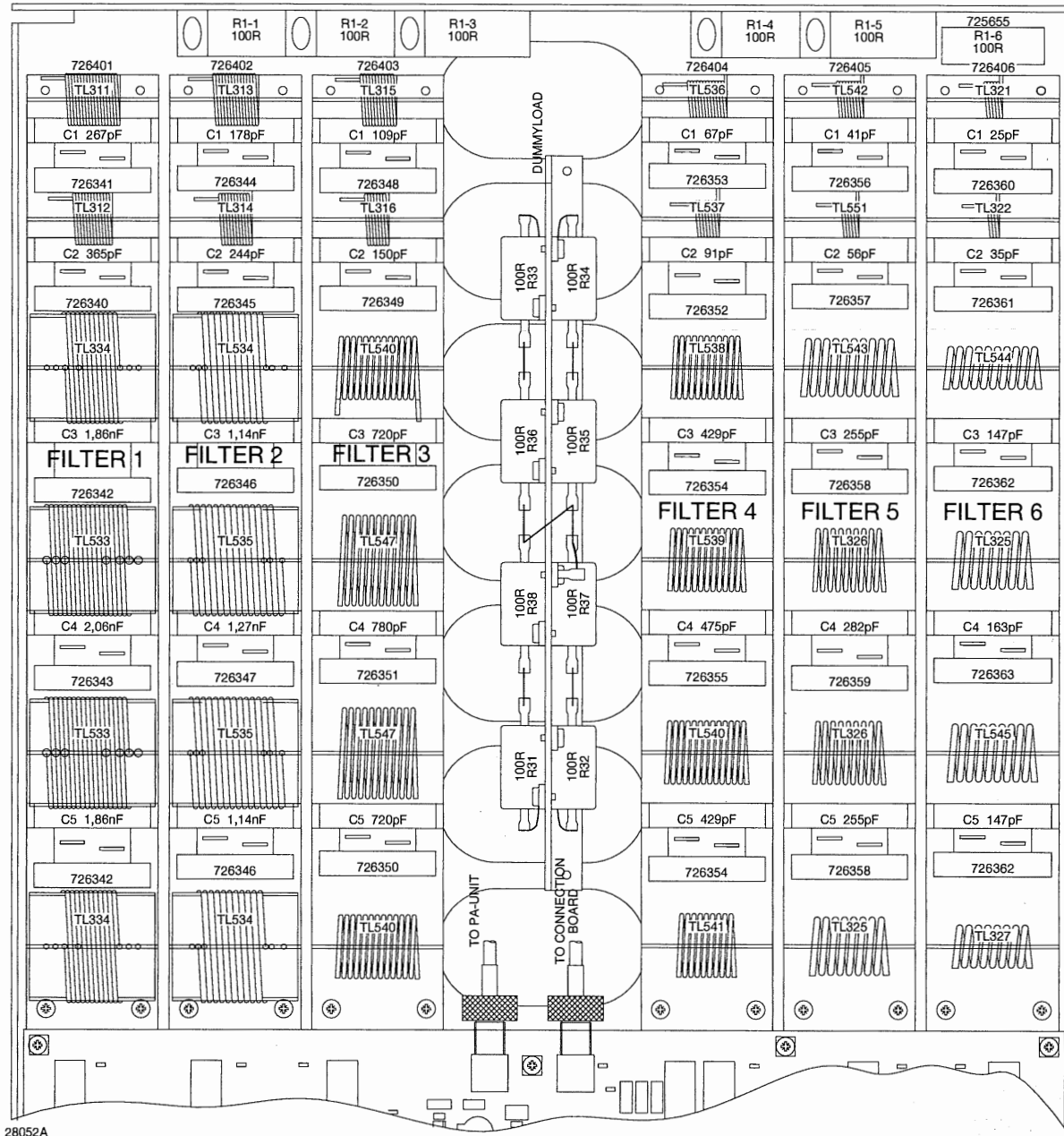

LP-FILTERS MODULE 1-6

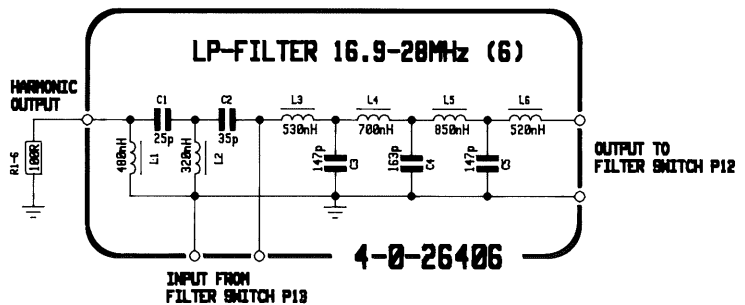
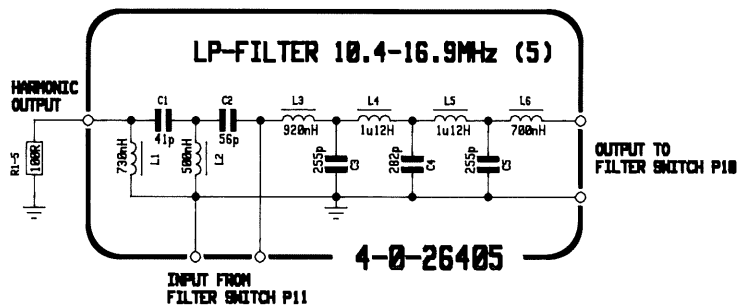
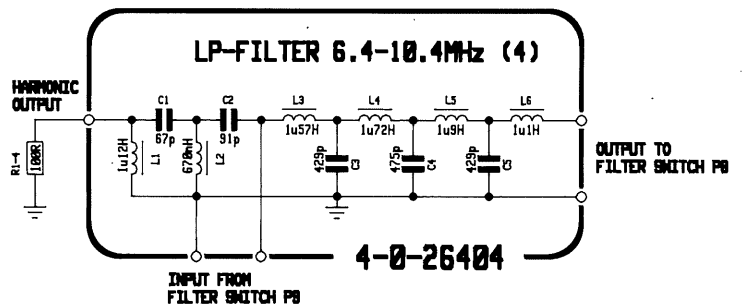
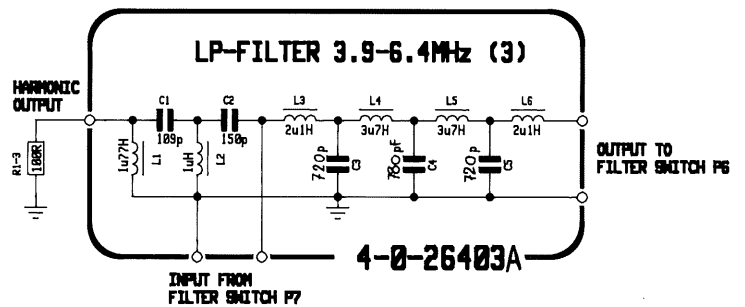
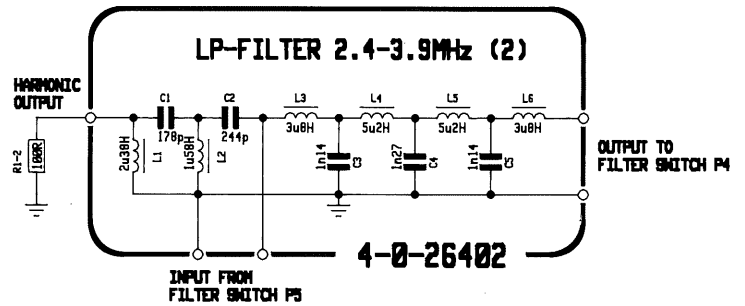
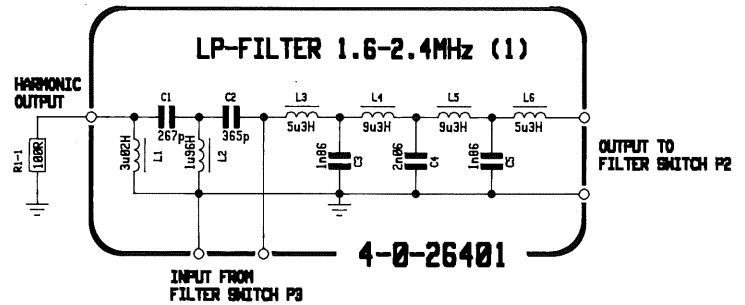

26401A

5.7 FILTER SWITCH UNIT (MODULE 7) PART NO. 627147

This module contains the relays for switching between the 6 lowpass filters and the SWR detector circuit.

The relays RE1 to RE12 and RE15 are controlled from the microprocessor.

The relays RE1 and RE2 are activated from	1.6 - 2.399 MHz
The relays RE3 and RE4 are activated from	2.4 - 3.899 MHz
The relays RE5 and RE6 are activated from	3.9 - 6.399 MHz
The relays RE7 and RE8 are activated from	6.4 - 10.399 MHz
The relays RE9 and RE10 are activated from	10.4 - 16.899 MHz
The relays RE11 and RE12 are activated from	16.9 - 28.000 MHz

The relay RE15 is activated when the power level is set during the first key on a new frequency. R1, and R4 is a voltage divider for the power out detector consisting of D1 and C1, C19. The power out voltage is fed to the microprocessor, which controls the power level. The SWR detector circuit consists of an SWR bridge (TR1, R6, R7, R8, R9 and C2, C3, C4 and C5), quasi effective value detector (D2, R12, R5, C12 and D3, R13, R14, C7) and a peak detector/buffer amplifier built around U1.

COMPONENT LOCATION FILTER SWITCH UNIT MODULE 7

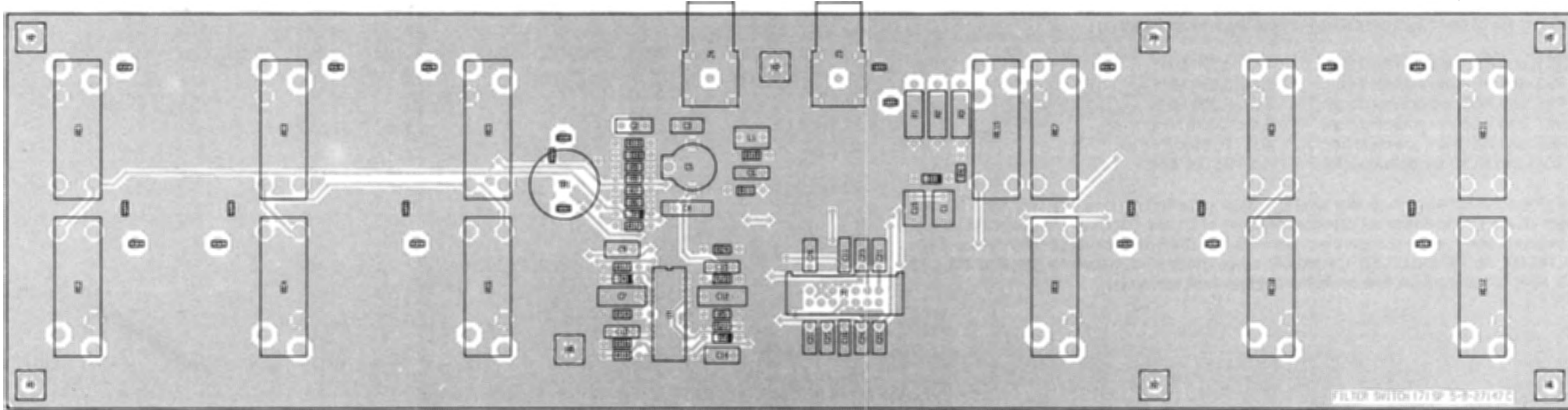

View from component side with upper side tracks.

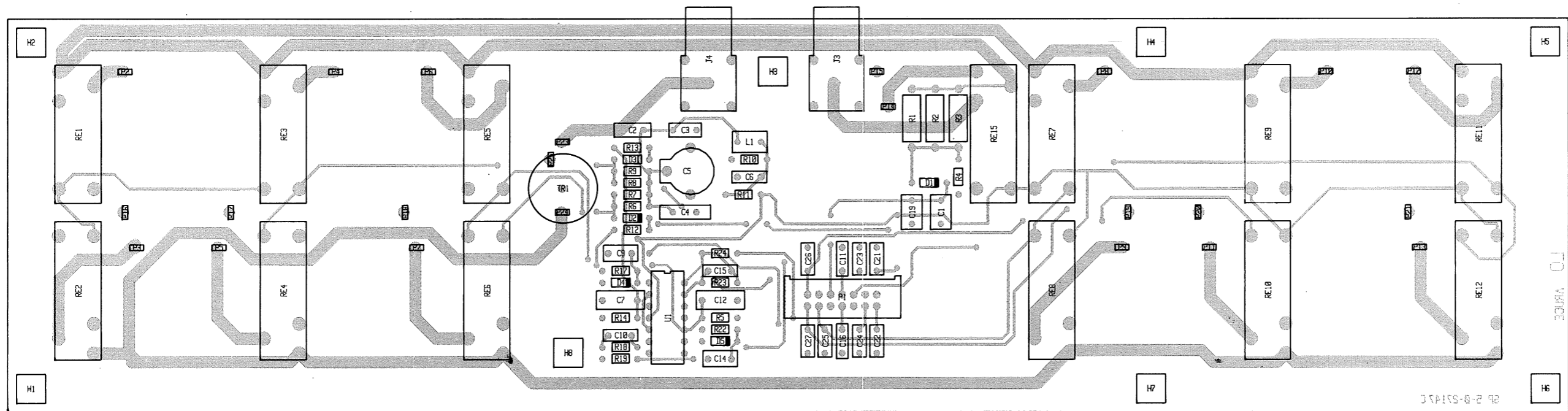

View from component side with lower side tracks.

FILTER SWITCH MODULE 7

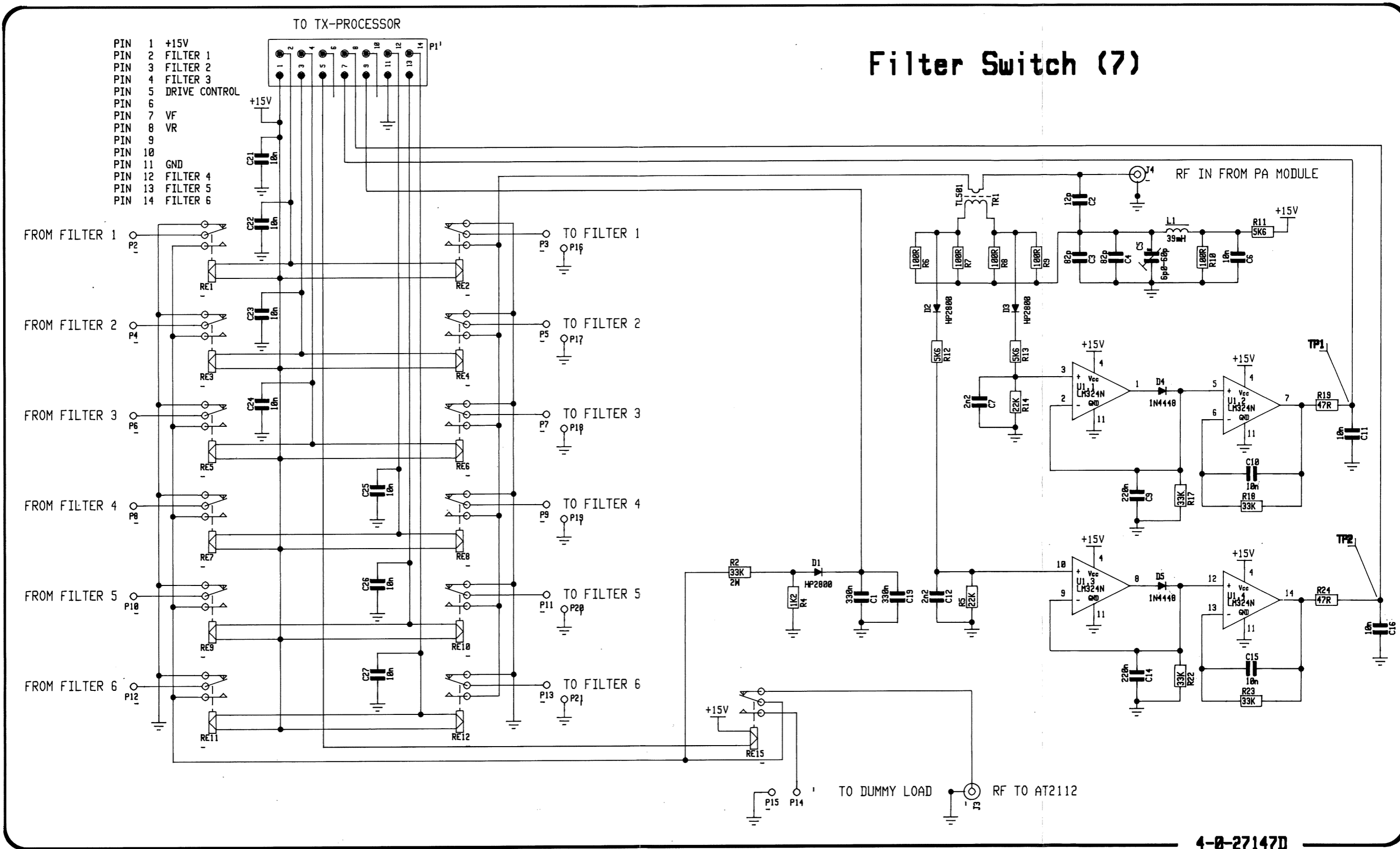

4-0-27147D

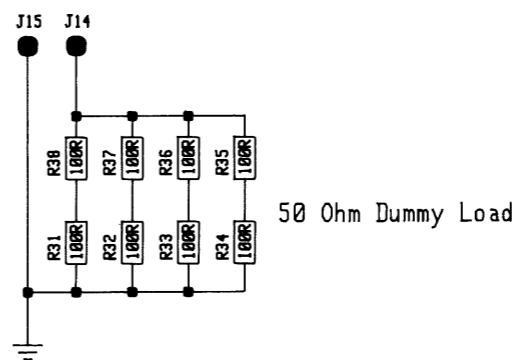

5.8 TX-PROCESSOR (MODULE 8) PART NO. 626408

This section applies to a T2131 (600 Watt) as well as a T2131/T2135 (1200 Watt) HF SSB transmitter. If you have a T2131 (600 Watt) transmitter, the text written about power amplifier B, power det. B and temp. B must be skipped.

FUNCTIONAL DESCRIPTION

The TX-processor has the following main functions:

- communicates with the RE2100
- switches in the power supply
- switches over to DC supply if the AC supply is failing
- switches in the correct lowpass filter
- sets the drive level
- tunes the AT2112 to an acceptable SWR
- remembers the AT2112 relay combination for an acceptable SWR
- protects the PA stage against high temperatures
- protects the PA stage against bad SWR
- protects the combiner against destruction if one power amplifier breaks down
- activates the AT2112 RX relay according to selected RX frequency
- activates the AT2112 relays, if RX and TX frequencies are the same

These functions are implemented partially in the hardware and partially in the software.

The TX-processor hardware is separated in a number of circuits, referring to the diagram:

- power supply
- microcomputer
- watch dog & battery low detector
- communication bus driver & receiver (SP-Bus)
- serial device bus driver & selector
- EEPROM's
- filter module driver
- power supply driver
- A/D Converter
- power det. A and B
- RF and telex controls
- AT2112 module driver
- tune motor control
- AE current and power-out conditioning
- option selections (jumpers)

POWER SUPPLY

The board is supplied with the following voltages via P5:

- GND
- +9V
- +18V
- 18V
- +28V

These voltage are changed into the voltage regulator U25-U29 to the following internal supplies.

+5VA	general purpose 5 Volt
+5VB	back-up voltage. This supply is kept stable in a period after there has been a switch-off on the RE2100, or the AC or DC voltage has fallen accidentally.
-5V	used for the SP-Bus driver
+15V	supply for op-amps and for the output filter (module 2).
-15V	supply for op-amps
+18V	this is only used for sensing as the +5VB is generated from this supply.
+28V	supply for tune motor and AT2112 relays
GND	common to the above supplies.

MICROCOMPUTER

The purpose of the microcomputer block is to run the programme properly. It consists of the following units:

- an 8 bit Hitachi microprocessor, U03
- an EPROM, carrying the programme, U01
- chip select circuit for the EPROM U2/3
- a watch dog & battery low detector, U04.

WATCH DOG & BATTERY LOW DETECTOR

The MAX 690 (U04) has the following purposes:

- ensures a proper reset for the microprocessor when the +5VB is stable.
- senses the +18V (PFI, pin 4), and gives an early warning when the supply is failing.
The limits for the battery low detector are the as follows:
 - The PFO (pin 5) must be high (+5V) at 17.231 Volt or higher on the +18V
 - The PFO must be low (0V) at 14.148 Volt or less on the +18V supply.
- watch dog

During normal operation the microprocessor resets the watch dog at known locations in the programme. If the microprocessor stays too long time in an unintentional loop, without resetting the watch dog, the watch dog will activate the reset pin on the microprocessor.

This may happen if the microprocessor is waiting for an event, which never happens (e.g. failure in hardware), or noise has disturbed the programme execution.

The watch dog function may be disabled by inserting jumper 2 in the P02. This may make fault finding in the T2131/T2135 easier.

SP-BUS DRIVER & RECEIVER

The communication to the RE2100 is time multiplexed data bus.

It is implemented with one 50 Ohm coax cable terminated in each end, and a driver and a receiver is connected in each end. The RE2100 is the master and a number of slaves may be connected to the SP-Bus.

The driver and the receiver are identical in each unit connected to the SP-Bus.

The driver output is normally in high impedance state except when transmitting on the SP-Bus.

The driver consists of two gates, U02/1 & U02/2 (74HC132), a transistor Q01 (BC558) for level shifting and two complementary output transistors Q02 (BC328), Q03 (BC338).

The driver is connected to the microprocessor U03, pin 13 (port 2, bit 4, transmit data), and pin 9 (port 2, bit 1, driver enable).

The receiver consists of an op-amp, U06/1 (1458), which is configured as a Schmitt Trigger and a gate U05/4 (74HC08) for level conditioning.

The receiver is connected to the microprocessor U03, pin 12 (port 2, bit 3, receive data). As the levels on the SP-Bus approximately matches the RS232C standard, it is possible to connect an RS232C to the SP-Bus. The cable terminations (jumper P2) must be removed when the RS232C is to transmit on the SP-Bus.

SERIAL DEVICE BUS DRIVER

The serial device bus consists of:

- clock
- data out
- data in
- several select lines
- special select for the A/D converter

The serial bus occupies 6 bits of port 6 on the microprocessor. Bit 0, bit 1 and bit 2 are connected to the serial device selector. Bit 3 is the special select for the A/D converter. Bit 6 is clock, bit 7 is data.

The serial device selector is a 3 to 8 line decoder 74HC237 (U07). The 3 input lines give 8 selects on the output, one selected at a time. The following codes are used:

- 0 - none is selected
- 1 - EEPROM U8
- 2 - EEPROM U9
- 3 - shift register U10, filter module driver
- 4 - shift register U12, tune motor control
- 5 - shift register U17,U18, areal coupler driver
- 6 - shift register U11, power supply module driver
- 7 - A/D converter, reference voltage switch.

The serial device selector is supplied by +5VB.

The serial device bus driver consists of 3 lines:

- clock, port 6, bit 6
- data out, port 6, bit 7
- data in, port 6, bit 7

In order to have a safe communication the clock and data out are buffered. The buffers are 74HC08 (U05/1 and U05/2) supplied by +5VB.

The data in line is connected direct to port 6, bit 7. R04 ensures a definite impedance on the data in line.

To inhibit an unknown current sink in the serial device bus when the supply is failing, the buffers are gated with PFO signal from the battery low detector (U4, pin 5).

EEPROM's

U8 and U9 EEPROM's are supplied by the back-up voltage +5VB. They are connected to the serial device bus direct to the microprocessor, as the serial device bus closes down when the +18V is failing.

U8 and U9 EEPROM's remember the data for the fast retune of the AT2112.

By use of service programmes it is possible to delete these retune data.

U8 and U9 EEPROM's are from S. P. Radio initialized and programmed with certain constants related to the specific T2131/T2135, where the TX-processor is located. The constants are saved in the EEPROM's by use of service programmes.

When any of the EEPROM's are replaced, both must be initialized again and the T2131/T2135 must be calibrated. Refer to the service programmes.

When the TX-processor board is replaced or is moved to another T2131/T2135, the T2131/T2135 must be calibrated again. Refer to the service programmes.

FILTER MODULE DRIVER

This unit activates all relays on the output filter module (1). It consists of a serial to parallel shift register U10, 74HC595 and 8 open collector Darlington drivers, located in U14 and U21 (MC1413/ ULN2003).

The filter module driver is connected to the serial device bus and supplied from the +5VA. The +15V is connected to U14 and U21 for protection purposes.

POWER SUPPLY DRIVER

This unit activates all the power supplies in the N2170 and N2171.

It consists of a serial to parallel shift register U11, 74HC595 and open collector Darlington drivers, located in U14 and U22 (MC1413 / ULN2003) pulled up by 8x10 kohm resistors.

The power supply driver is connected to the serial device bus and supplied from the +5VA. The +15V is connected to U14 and U22 for protection purposes.

A/D CONVERTER AND SURROUNDING CIRCUITS

The A/D converter converts the following analog signals to digital values:

- forward voltage, (VF)
- reverse voltage, (VR)
- power out voltage, (Pout)
- temperature in power amplifier A, (converted to a voltage)
- temperature in power amplifier B, (converted to a voltage)
- power out from power amplifier A, (power det. A)
- power out from power amplifier B, (power det. B)
- power in voltage, (Pin)

The ADC (U13, ADC0838) is an 8 bit converter and an 8 channel multiplexer (MUX). Data in and out are serial.

The ADC is connected to the serial device bus and to a reference voltage, +5.00V to the Vref input (pin 12). It is possible to switch the Vforward to the Vref input (pin 12) on the ADC and do a ratiometric measuring with Vforward and Vref giving the parameter RHO direct.

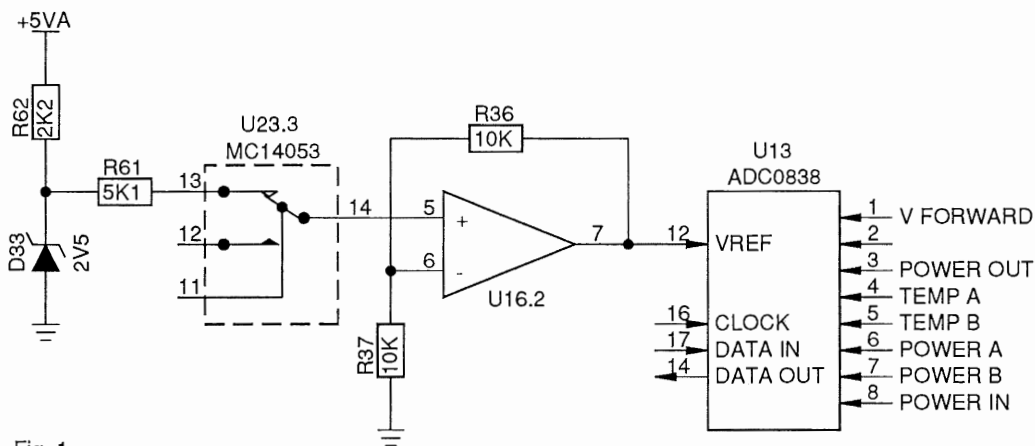

Fig. 1
28358

Measuring Vforward (VF), power out, temperature A and B, power det. A and B, and power in.

When measuring a voltage, the Vref (pin 12) is at +5.0 Volt. The reference diode D33 (LM385) gives +2.5 Volt. The analog switch U23/3 (MC14053) is controlled by the serial device selector and connects the 2.5 Volt reference to the non inverting input of the op-amp U16/2. The op-amp has a gain of 2, giving the 5.0 Volt reference to the ADC, pin 12.

- VF (P4 pin 7) is connected to channel 0 pin 1 of the MUX in the ADC via a divider, R56, R55, R54.
- VR (P4 pin 8) is connected to channel 1 pin 2 of the MUX in the ADC via a divider, R60, R59.
- Power out (P4 pin 9) is connected to channel 2 pin 3 of the MUX in the ADC via a divider, R58, R57
- Temperature from power amplifier A. The temperature sensor R64 (KTY11-2B) is placed near the output transistors in the power amplifier A (11) and is connected to the TX processor in P05, pin 10 and pin 11.
- Temperature from power amplifier B. The temperature sensor R64 (KTY11-2B) is placed near the output transistors in the power amplifier B (11) and is connected to the TX processor in P05, pin 12 and pin 13.

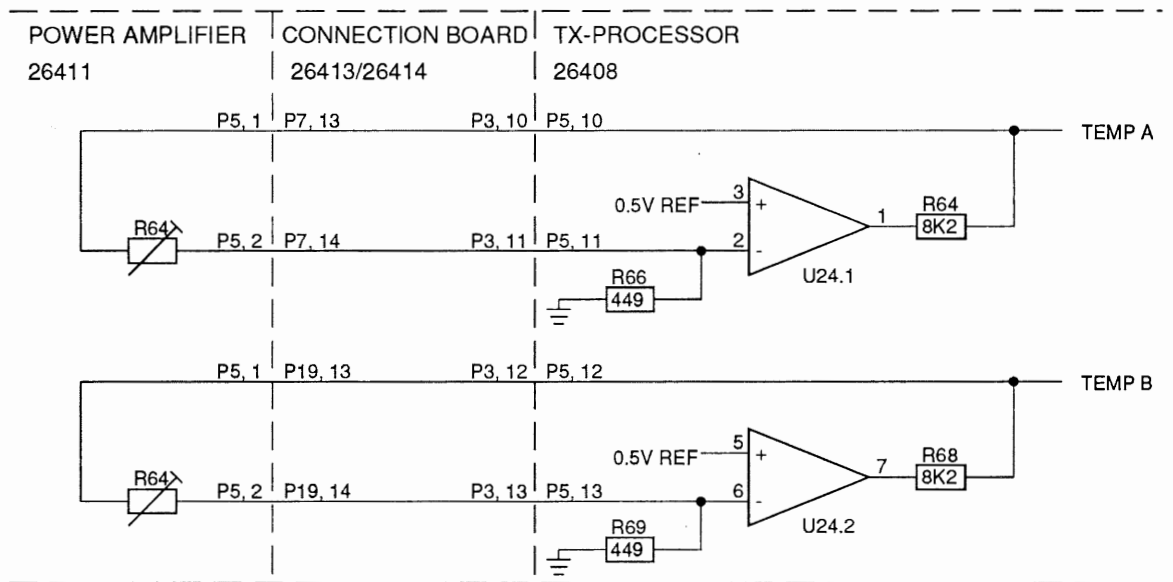

Fig. 2
28359

Fig. Temperature sensor connections

Temperature from Power Amplifier

The sensor is a nonlinear resistive element, which has 2.000 Kohm at 1 mA and 25°C. The op-amp U24/1 is a voltage-to-current converter. The input voltage is the 2.5 Volt reference divided by the resistors R65 and R70, which gives 0.500 Volt at the non inverting input of the op-amp. The resistor from the inverting input to ground is 449 Ohm and gives a constant current flow (1 mA) in the sensor connected from the output to the inverting input of the op-amp. R64 and C37,C62 inhibits the op-amp from oscillating.

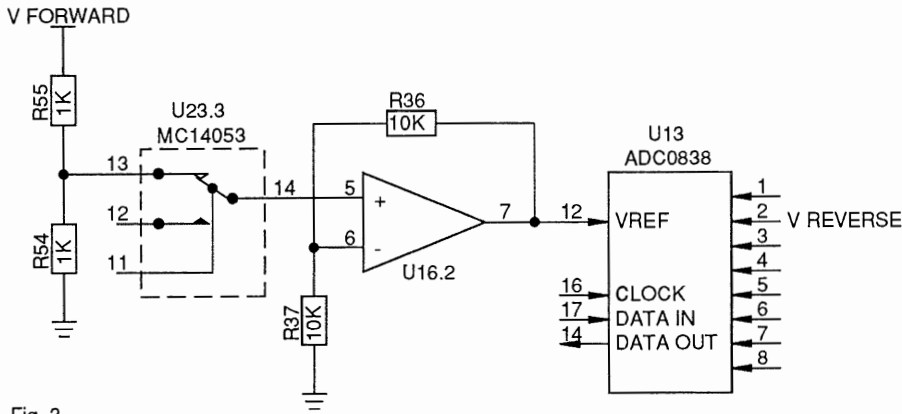

Fig. 3
28360

Fig. Measuring RHO

When Measuring RHO, the Vforward is connected to reference input of the ADC (U13, pin 12). Vreverse is connected to pin 2. The result of the ratiometric measuring is the parameter RHO, defined by Vreverse divided by Vforward.

POWER DET. A AND B

During rise or after a fatal error, the intelligent fault system investigates which power amplifier has been installed. This is done in the following way.

Two 10 kohm (R31,R32) pull-up resistors are connected to the power det. A and power det. B during Q8 and Q9.

If only one power amplifier (A) is installed.
The power det. A line on U13 pin 6 is low app. 0.9 volt, and
the power det. B line on U13 pin 7 is high app. 4.0 volt.

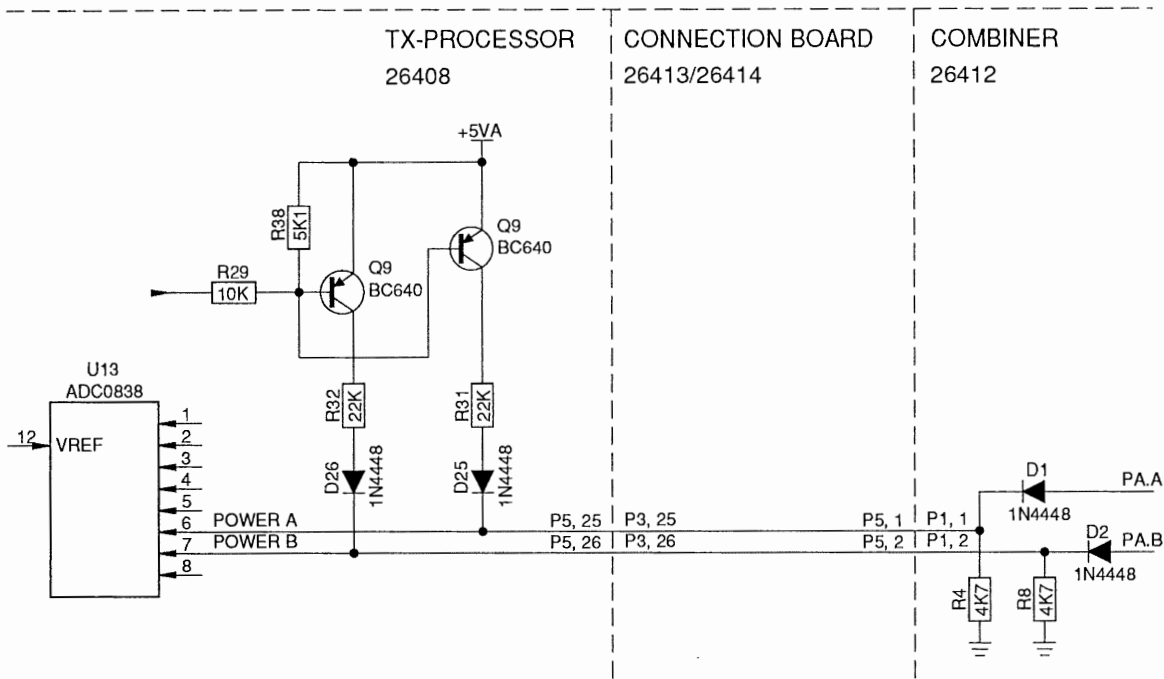

Fig. 4
28361

Fig. Power detector A and B

RF AND TELEX

The transistor Q4 is the telex open function and Q5 is the RF on/off function. Both are controlled direct from the microprocessor, (port 6, bit 4 and bit 5).

The RF on/off controls the bias for the power transistors by means of the transistors Q02, Q05 and Q11 in the power amplifier.

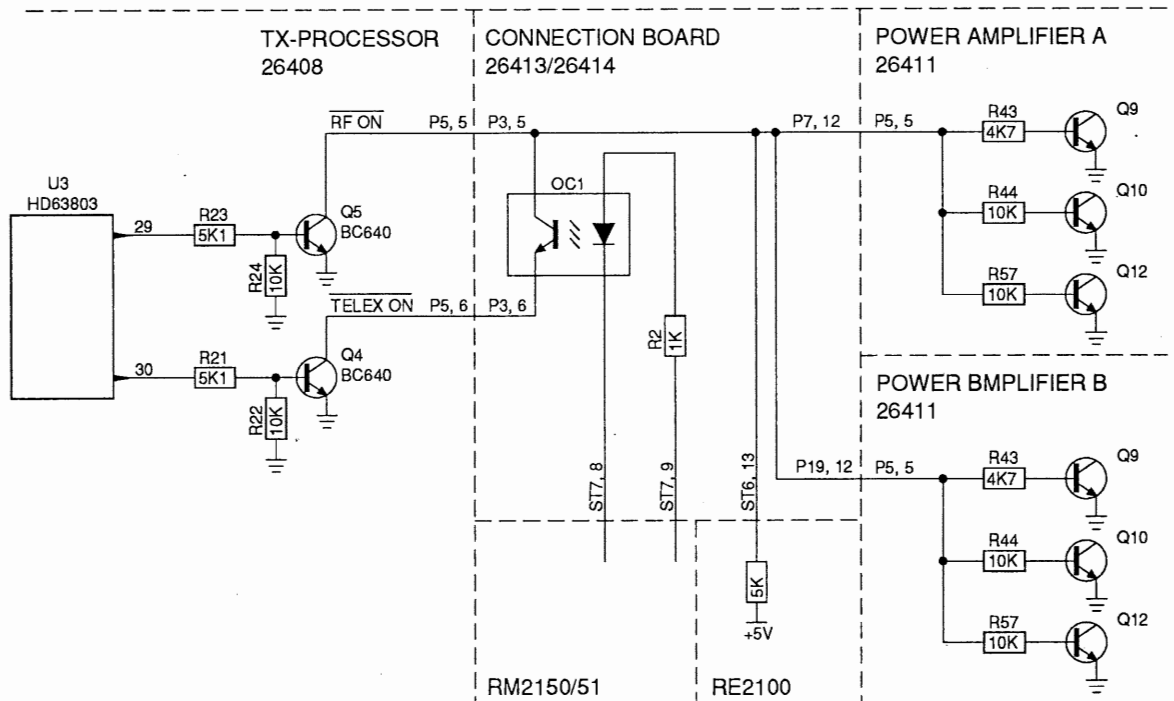

Fig. 5
28362

Fig. RF and telex control

RF off and Telex Closed

Q4 is off and Q5 is off. This means that the transistors Q9, Q10, Q12 in power amplifier is at saturation state by a current flow from +5V through 5 kohm in the RE2100.

RF on: (During tune and "key" from the handset)

Q4 is off and Q5 is on. The transistors Q9, Q10, Q12 in the power amplifier is at off state.

Telex open ("key" from the Telex equipment)

Q4 is on and Q5 is off. This allows the optocoupler L2, L3, L4 in the connection board (14) from the RM2151 to control the RF on/off function to the power amplifier.

AT2112 DRIVER

This unit activates all relays in the AT2112. It consists of two serial to parallel shift registers U17, U19, 74HC595 and 16 source Darlington drivers, located in U18 and U19 (UDN2981A).

The areal module driver is connected to the serial device bus and supplied from the +5VA. The source driver (U18, U20) is supplied from +28V. D4-D17 and GND are connected to U18 and U20 for protection purposes.

TUNE MOTOR CONTROL

The main function of this circuit is to control the M01 in the AT2112 at two speeds, high and low, and when the variable inductor has rotated one half to stop the tune motor. The speed of the motor is selected from the microprocessor via the serial device bus and the shift register U12 (74HC595), (high speed pin 7), (low speed pin 6). The signal from U12 pin 6 (low speed) is divided by R25 and R26, where the signal from U12 pin 7 (high speed) is applied direct to the non-inverting input of the op-amp. The op-amp. U15/1 has a gain of app. 4.6. The output voltage is buffered by the output transistors Q6 and Q7.

When the motor is running, as it does in the moment when the power is turned on (high speed) or when tuning the AT2112 (high or low speed), a current flows into the light emitting diode in the optocoupler L2,L3,L4 on the aerial current detector module (1) in the AT2112.

The transistor Q02 is saturated via R05 and the collector current flows in the LED in the L2,L3,L4 and the resistor R26. The detectors in the optocoupler L2,L3,L4 and Q01 on the aerial current detector module (1) are both in saturation state caused by the light from the emitter in the L2,L3,L4.

The transistor Q10 on the TX-processor (8) is on (controlled by the microprocessor). This ensures a current flow in R48 on the TX-processor (8) and in Q01 (and the detector in L2,L3,L4) on the aerial current detector module in the AT2112. The collector of the Q01 on the aerial current detector module in the AT2112 is sensed by the divider R47 and R46 and the driver U14/4 (MC1413) which is connected to the microprocessor, port 5 bit 7, (U02, pin 24). The light is broken in the open type optocoupler L2,L3,L4 on the aerial current detector module (1) when the variable inductor C01 in AT2112 has maximum induction and when it has minimum induction (every 180°). When the light is broken in the optocoupler L2,L3,L4, the current flow stops in the detector in L2,L3,L4 and Q01 on the aerial current detector module (1) in AT2112. This gives a level shift, which is detected by driver U14/4 and the microprocessor is informed. The microprocessor turns off the supply voltage to the motor M01 and the rotation stops. When the motor M01 must run at low (the AT2112 is tuning) it is always started at high speed and reduced to low speed when the rotation has begun. The high speed time period is the time it takes to rotate the variable inductor C01 so far that the light from the light emitter diode in L2,L3,L4 turns on the detector in L2,L3,L4, and the transistor Q01 on the aerial current detector module (1). This is detected and the microprocessor will immediate change to low speed.

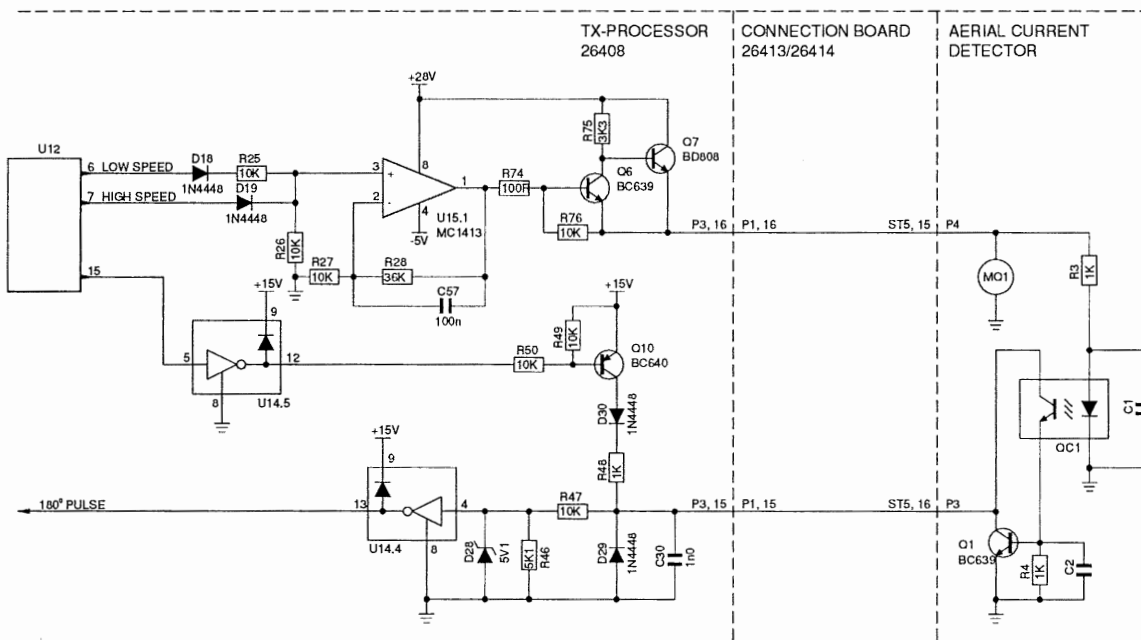

Fig. 6
28363

Fig. Motor control circuit

AE-CURRENT AND POWER OUT CONDITIONING

The signal 'AE-current' and the signal '180° pulse' share one wire between the AT2112 and T2131/T2135. This means that the 'AE-current' cannot be transferred to the Bar-graph in the RE2100 when the AT2112 is tuning. The 'POWER OUT' is transferred to the Bar-graph when the AT2112 is tuning. When the T2131/T2135 is keyed (the tuning has finished), the 'AE-current' is displayed on the Bar-graph.

If the jumper 5 is inserted in the P02 and the T2131/T2135 is keyed, the 'POWER OUT' is displayed on the Bar-graph.

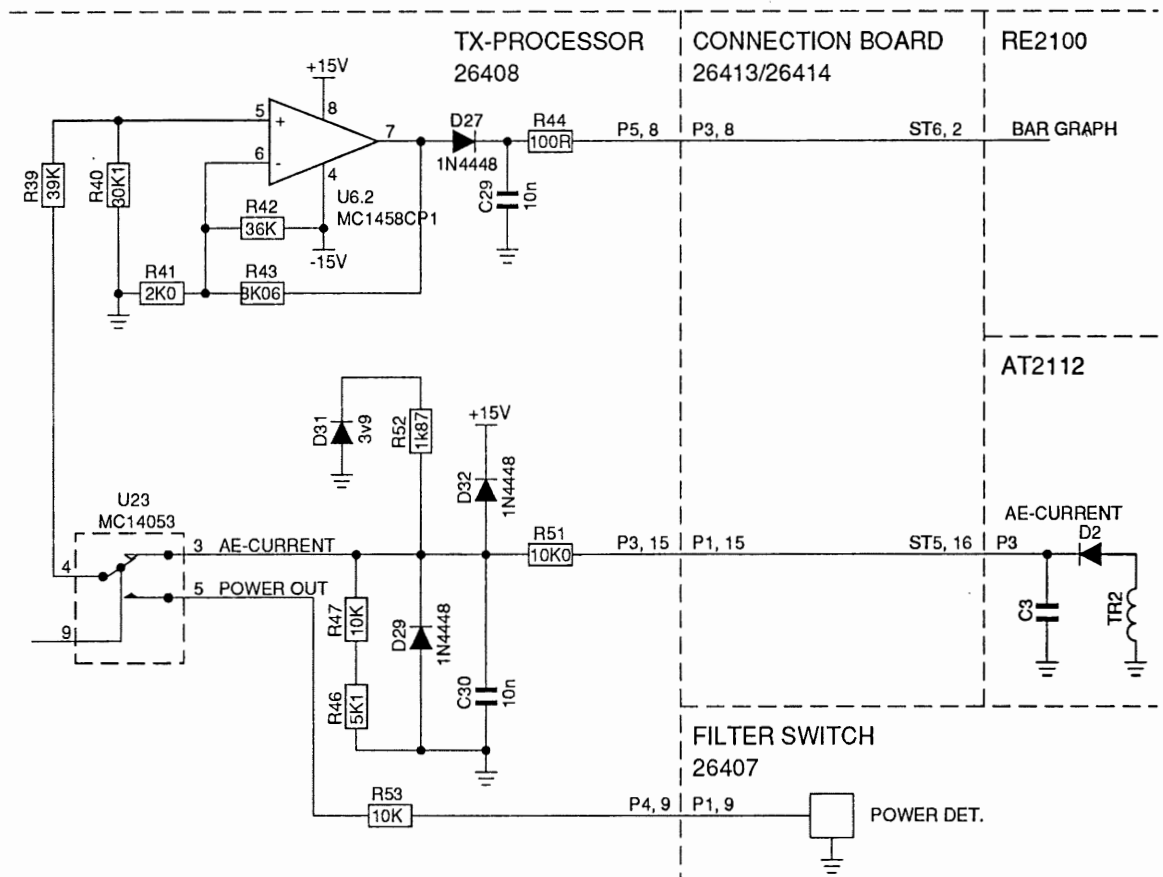

Fig. 7
28364A

Fig. AE-current / POWER OUT - Bar-graph

The analog switch U23/2, which is controlled by the microprocessor via the serial device bus and the shift register U12 and the driver U14/5, switches between the 'AE-current' and the 'POWER OUT'.

'AE-current' comes in from the AT2112 to the TX-processor in P3, pin 15 and is divided by the resistors R51, R39 and R40. When the level exceeds app. 3.9 Volt, the diode D31 opens and the dividing ratio is changed. This ensures that the level corresponds to the logarithmic scale on the RE2100.

The 'POWER OUT' comes in, from the output-filter (1) at P4, pin 9 and is divided by the resistors R53, R39 and R40. The selected signal is gained by U06/2 and surrounding resistors R41, R42, R43 and R44. The output is fed to P5, pin 8 and runs to the processor unit (8) in the RE2100, where it is conditioned and lead to the display unit (7) (in the RE2100), where it is mixed with the AGC-signal from the receiver module (1). Please refer to the circuit description for the RE2100 modules.

OPTION SELECTIONS (JUMPERS)

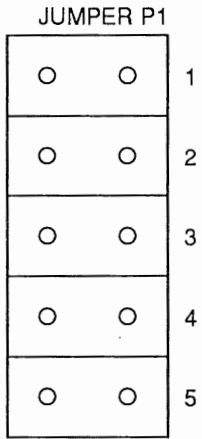

28365

Fig. Jumper Options

Jumper 1 is the upper one.

Jumper	Inserted	Out
1	The communication on the with SP-Bus is without parity bit.	Normal communication RE2100.
2	Watch dog reset disabled.	Normal operation of the watch dog.
3	The drive set is made without being disturbed of compression.	Normal operation.
4	Do not insert. For future use.	Normal operation.
5	This tells the microprocessor that a AT2112 does not exist in the system. All communication to the AT2112 is disabled.	Normal operation. The AT2112 is in the system.

Jumper 1 is:

The upper one on the TX processor 26408 (Ver,B,C, , ,).

COMPONENT LOCATION TX-PROCESSOR MODULE 8

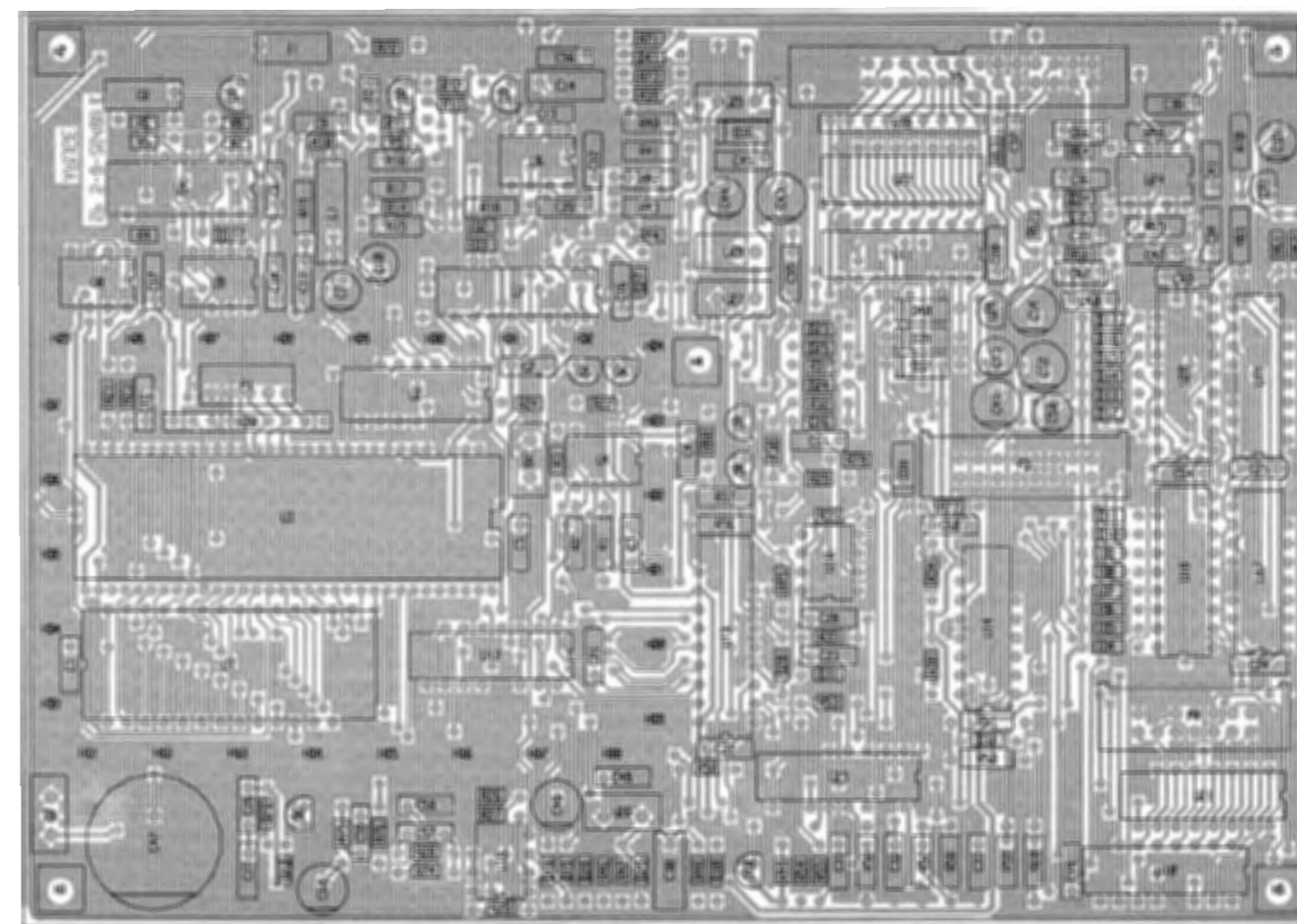
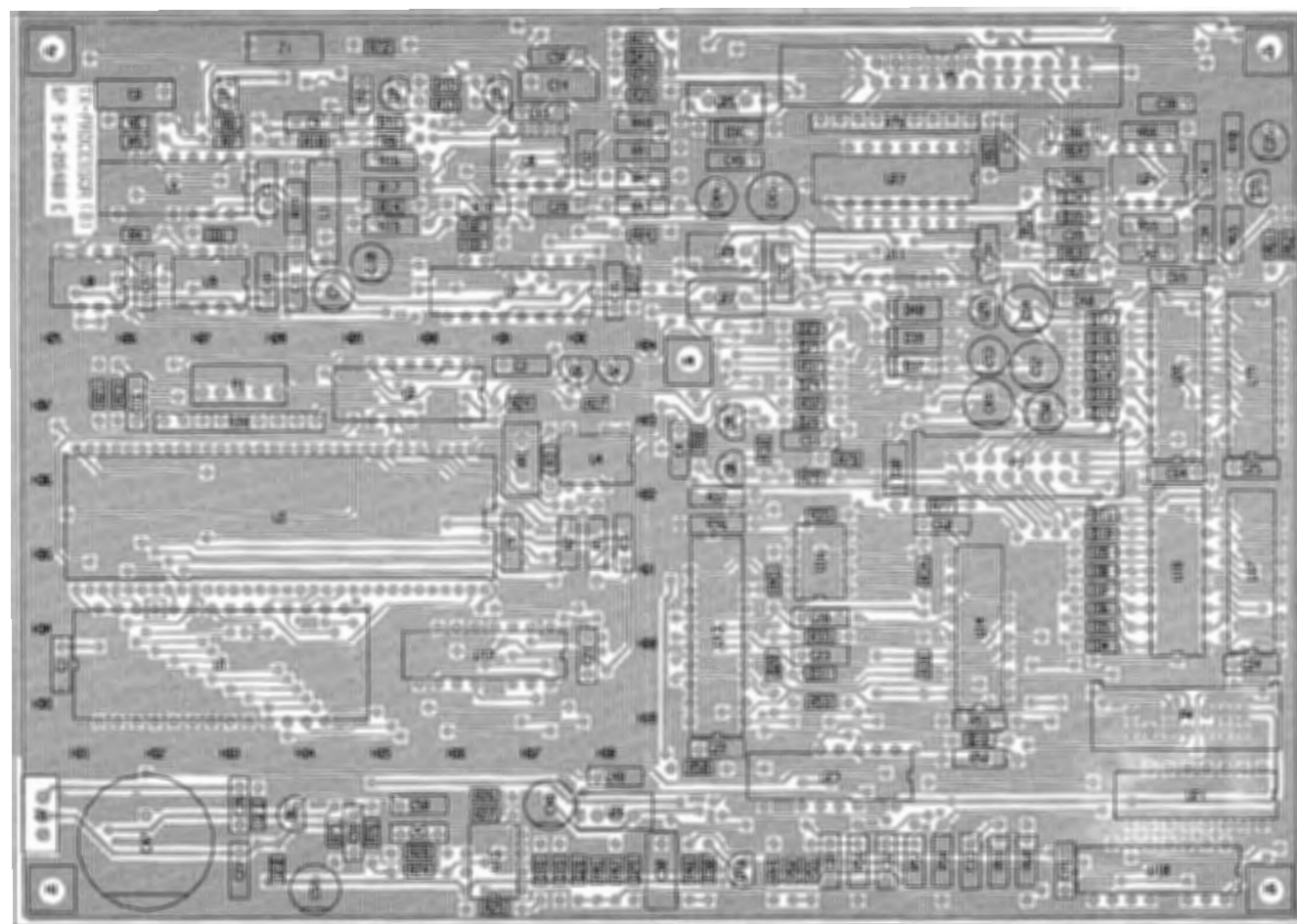

View from component side with upper side tracks.

View from component side with lower side tracks.

PCB rev. 26408E

TX-PROCESSOR MODULE 8

Tx-Processor (8)

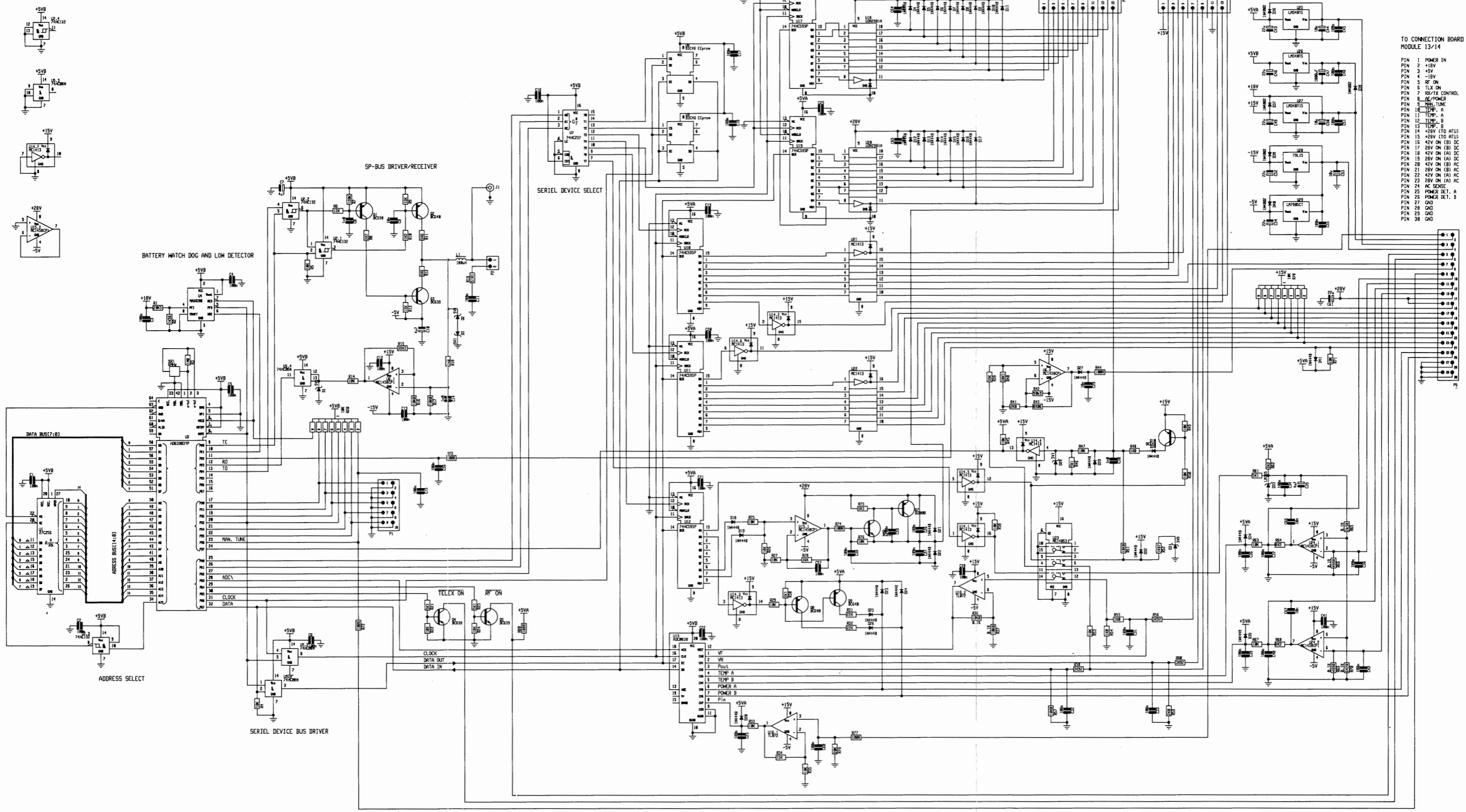

TO CONNECTION BOARD MODULE 13/14

PIN 1	CONTROL 2	PIN 9	CONTROL 10	PIN 17	+15V	PIN 8	VR
PIN 2	CONTROL 1	PIN 10	CONTROL 9	PIN 18	FILTER 1	PIN 9	POWER OUT
PIN 3	CONTROL 4	PIN 11	CONTROL 8	PIN 19	FILTER 2	PIN 10	TEMP. A
PIN 4	CONTROL 3	PIN 12	CONTROL 11	PIN 20	FILTER 3	PIN 11	GND
PIN 5	CONTROL 6	PIN 13	RX 4 4MHz	PIN 21	DRIVE CONTROL	PIN 12	FILTER 4
PIN 6	CONTROL 5	PIN 14	RX/TX	PIN 22	PIN 6	PIN 13	FILTER 5
PIN 7	CONTROL 8	PIN 15	AE/180P PULSE	PIN 23	PIN 7	PIN 14	FILTER 6
PIN 8	CONTROL 7	PIN 16	MOTOR				

TO CONNECTION BOARD MODULE 13/14

PIN 1	POWER IN	PIN 27	GND
PIN 2	+18V	PIN 28	GND
PIN 3	+5V	PIN 29	GND
PIN 4	-15V	PIN 30	GND
PIN 5	RF ON		
PIN 6	TLX ON		
PIN 7	ROX/TX CONTROL		
PIN 8	AC/POWER		
PIN 9	MAN. TUNE		
PIN 10	TEMP. A		
PIN 11	TEMP. B		
PIN 12	TEMP. C		
PIN 13	TEMP. D		
PIN 14	+28V (TO ATU)		
PIN 15	+28V (TO ATU)		
PIN 16	42V ON (B) DC		
PIN 17	28V ON (B) DC		
PIN 18	42V ON (A) DC		
PIN 19	28V ON (A) DC		
PIN 20	42V ON (B) AC		
PIN 21	28V ON (B) AC		
PIN 22	42V ON (A) AC		
PIN 23	28V ON (A) AC		
PIN 24	AC SENSE		
PIN 25	POWER DET. A		
PIN 26	POWER DET. B		
PIN 27	GND		
PIN 28	GND		
PIN 29	GND		
PIN 30	GND		

5.9 POWER SUPPLY (MODULE 9) PART NO. 626409

The power supply is an isolated forward switch mode converter. It converts a 24V -10% +30% DC voltage to all the necessary voltages for the RE2100 and the control circuits in the transmitter. These voltages are $\pm 19V$ and +9.5V.

Most of the necessary amplifiers, flip-flops etc. are contained in the ICU1. The only exception from this, is the secondary voltage sense D18.

C2, C26, C27, L1, C3, C4 and C12, C13 are the input filter. The 12V DC supply voltage for U1 is supplied to R2, D7, C8, Q4 and C9 during starting-up. When the converter is in function it is supplied by L2 and D8, D9. This voltage is approx. 15 Volt and forces Q1 to turn off. This configuration reduces the power loss in Q1. R5 and C7 determine the oscillator frequency to approx. 50 kHz.

The +18V DC output voltage is sensed by D18 via the voltage divider R27 and R28. D18 is an integrated shunt regulator. If the voltage on the sense input (R27/R28 common point) is higher than 2.5V, then the D18 starts conducting. In this case, current starts running in the optocoupler diode OC2.

R26 is a DC feed-back and R25/C19 is an AC feed-back.

R24 limits the current in the optocoupler diode.

When current runs in the optocoupler diode, the optocoupler transistor (OC2) starts conducting nearly the same current. This current results in a voltage across R6. This voltage is connected to the non inverting input of the internal error amplifier of U1. The internal error amplifier is fixed to a gain of 2 by R7 and R8. The output MOS transistor current is sensed by R17 and R18. The current signal is then led to the current sense amplifier input, pin 4. The R15 and C11 is a lowpass filter to remove noise. The emitter of Q2 follows the ramp voltage on the oscillator capacitor C7. R12 adds some of this ramp signal to the current signal. This is necessary to avoid sub-harmonic oscillations when the duty cycle is higher than 50%.

The voltage on pin 1 determines the clamp voltage for the error voltage and thus also the max. current in the output MOS transistors. This voltage is determined by R3 and R4. The capacitor C6 is the soft start capacitor, making the duty cycle and the output voltage rise slowly.

The two pulse width modulated outputs are led to the two output MOS transistors by R13 and R14. These two resistors slow down the rising time of the MOS transistors to prevent spurious oscillations.

R16 and R20 ensure that the transistors always stay off when the IC U1 is off.

R19, C15 and R21, C16 and R22, C17 and R23, C18 are snappers reducing oscillation due to stray capacitors and stray inductions in the transformer TR1.

D12 to D17 and L3 to L5 and C20 to C25 are the three output rectifiers and filters.

The input voltage is sensed by a 0.35 Volt shut down terminal pin 16 of U1 via R9, R10 and R11.

If the supply voltage is higher than approx. 45V DC, the converter stops.

COMPONENT LOCATION POWER SUPPLY MODULE 9

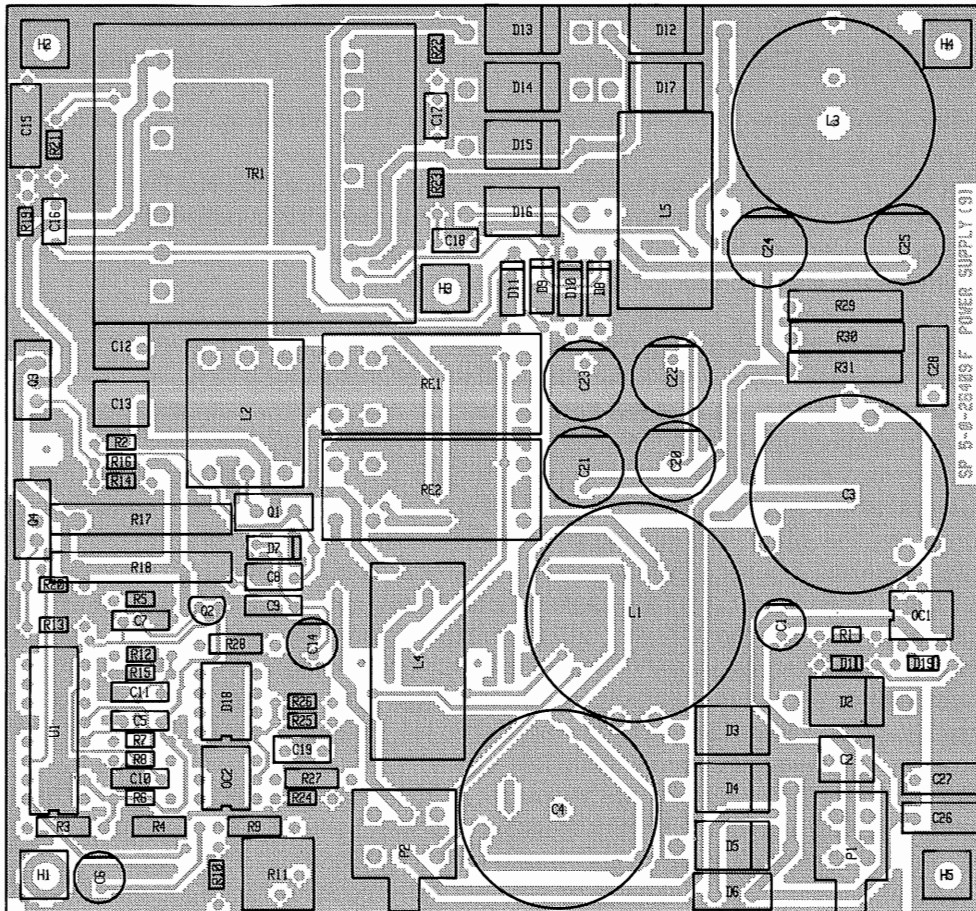

View from component side with upper side tracks.

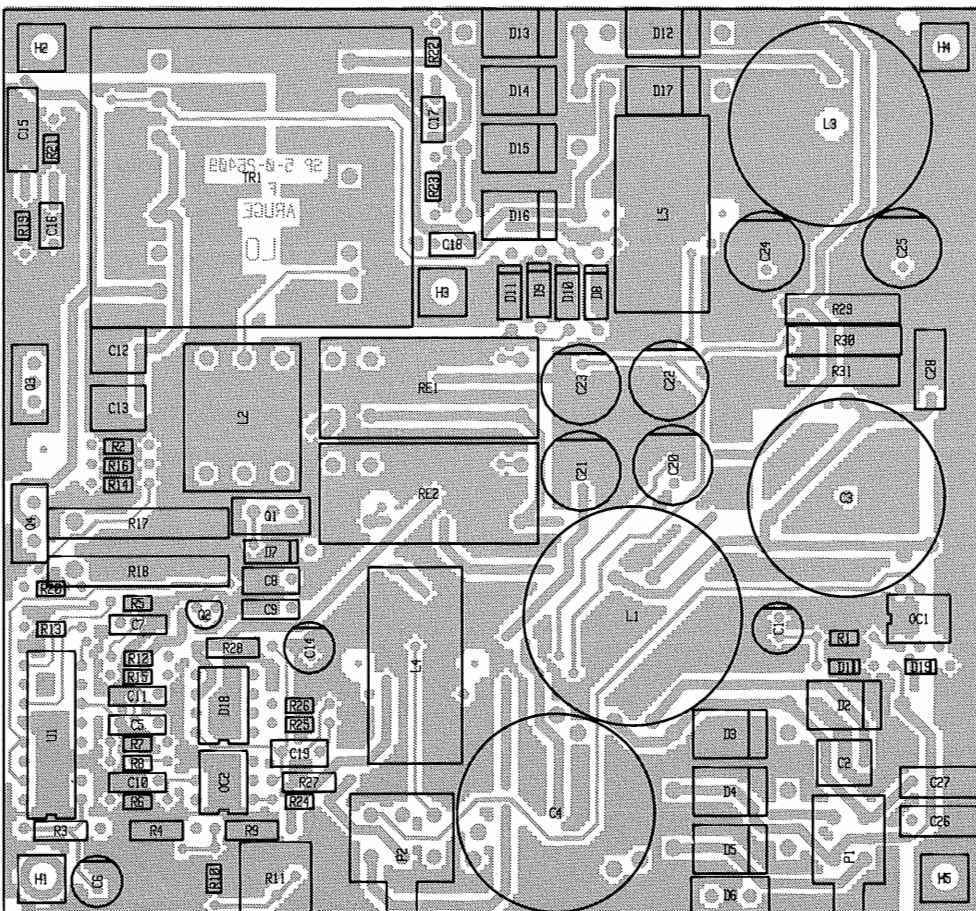

View from component side with lower side tracks.

POWER SUPPLY MODULE 9

4-0-26409E

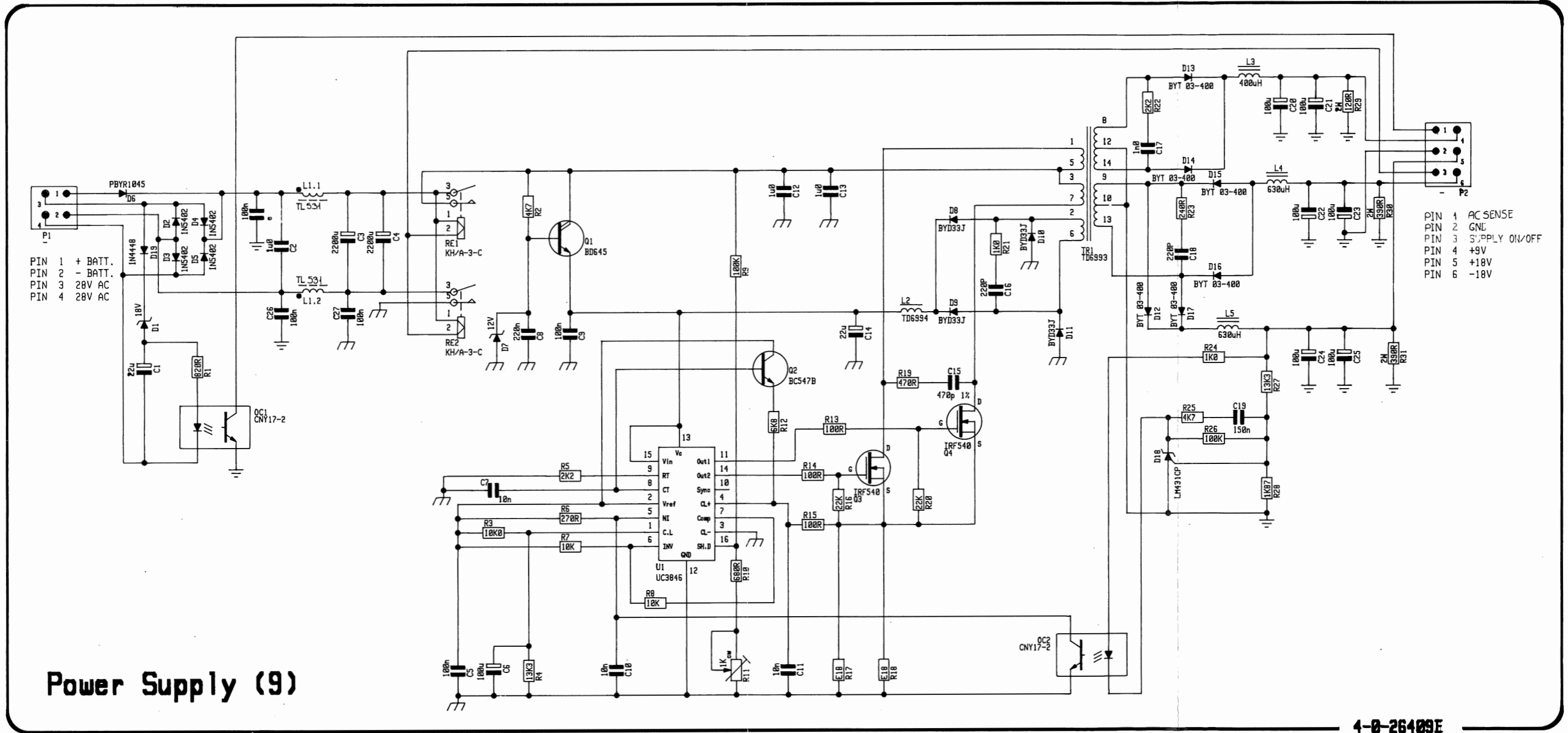

5.10 AF-AMPLIFIER (MODULE 10) PART NO. 626410

The audio amplifier is an integrated circuit TDA2030 U1, and it is supplied from the 28 Volt supply for the PA module. To insulate the battery from ground, there is a transformer TR1 at the input of the amplifier. RE1 and Q1 form a muting circuit for the loudspeaker. This circuit is controlled from the processor.

COMPONENT LOCATION AF-AMPLIFIER MODULE 10

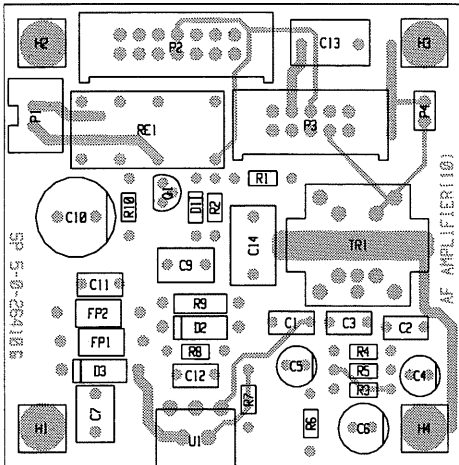

View from component side with upper side tracks.

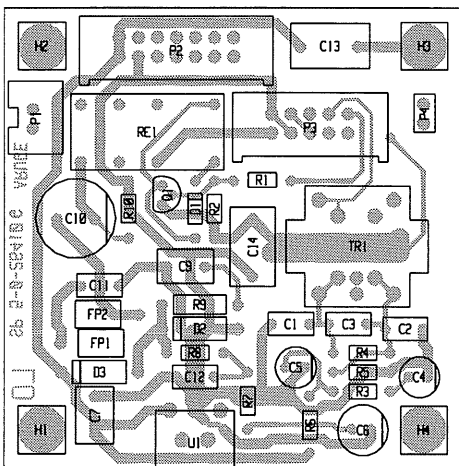

View from component side with lower side tracks.

PCB rev. 26410G

AF-AMPLIFIER MODULE 10

AF-amplifier (10)

TO LOUDSPEAKER

- PIN 1 -BATT.
- PIN 2 AF-OUT

TO SYNTHESIZER RE2100

- PIN 1 +28V
- PIN 2 +28V
- PIN 3 -BATT.
- PIN 4 NC
- PIN 5
- PIN 6
- PIN 7
- PIN 8 +18V
- PIN 9
- PIN 10
- PIN 11
- PIN 12
- PIN 13
- PIN 14

TO RECEIVER RE2100
TO CONNECTION BOARD

- PIN 1 AF-OUT
- PIN 2 -BATT.
- PIN 3 -BATT.
- PIN 4 +28V
- PIN 5 +28V
- PIN 6 +18V
- PIN 7 AF-IN COMMON
- PIN 8 AF-IN
- PIN 9
- PIN 10 MUTE LOUDSPEAKER

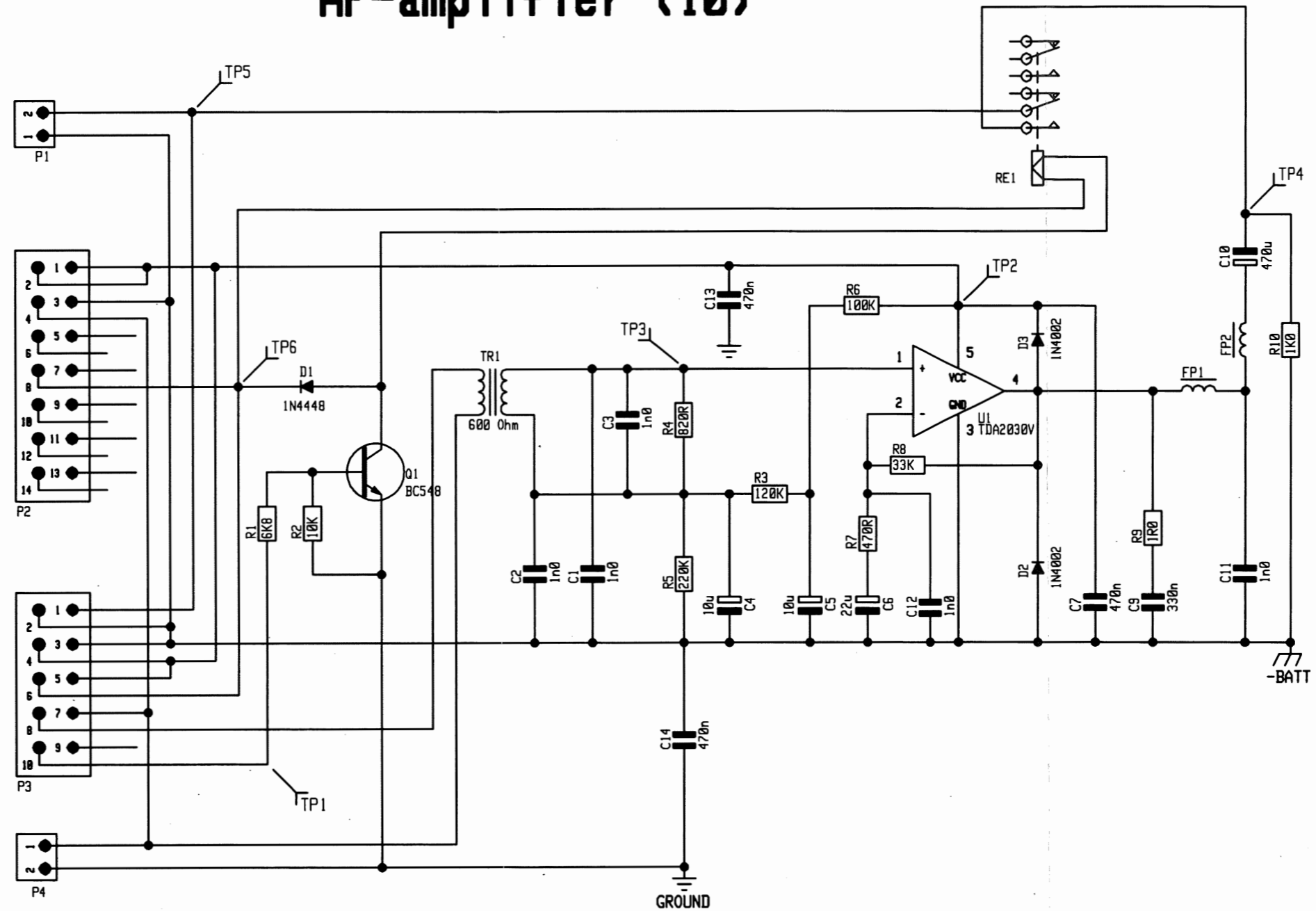

4-0-264101

This diagram is valid for PCB rev. 26410G

CONTENTS

6 PARTS LISTS

6-1

GRØN SIDE

6 PARTS LISTS

TX CONTROL UNIT 600/1200W		HF SSB PROGRAMME	ECI A/S	0-0-26391	726391
POSITION	DESCRIPTION		MANUFACTOR	TYPE	PART NO.
VARIOUS	COAX CABLE Ø3X28,5CM		ECI A/S	3-0-26095	526095
VARIOUS	COAXIAL CABLE 350mm FOR	OUTPUTFILTER T2131/35	ECI A/S	3-0-26883	526883
VARIOUS	COAXIAL CABLE 205mm FOR	OUTPUTFILTER T2131/35	ECI A/S	3-0-26884	526884
VARIOUS	COAX CABLE Ø5x66cm		ECI A/S	0-0-26920	526920
VARIOUS	INTERCONNECTION CABLE	30 POLES L=295mm	3M	3-0-26911B	56.043
VARIOUS	INTERCONNECTION CABLE	16 POLES L=295mm	3M	3-0-26912C	56.044
VARIOUS	INTERCONNECTION CABLE	10 POLES L=595mm	3M	3-0-26913C	56.045
VARIOUS	INTERCONNECTION CABLE	14 POLES l=130mm	3M	3-0-26914B	56.046
VARIOUS	JUMPER KIT 6/1200W 726391	HF SSB 600/1200W	ECI A/S	0-0-27767	727767
-1	FILTER UNIT MODULE 1	600/1200W HF SSB	ECI A/S	0-0-26401	726401
-2	FILTER UNIT MODULE 2	600/1200W HF SSB	ECI A/S	0-0-26402	726402
-3	FILTER UNIT MODULE 3	600/1200W HF SSB	ECI A/S	0-0-26403	726403
-4	FILTER UNIT MODULE 4	600/1200W HF SSB	ECI A/S	0-0-26404	726404
-5	FILTER UNIT MODULE 5	600/1200W HF SSB	ECI A/S	0-0-26405	726405
-6	FILTER UNIT MODULE 6	600/1200W HF SSB	ECI A/S	0-0-26406	726406
-7	FILTER SWITCH MODULE 7	T2131/35	ECI A/S	5-0-27147C / 4-0-27147D	627147
-8	TX PROCESSOR MODULE (8)	T2131/35	ECI A/S	5-0-26408E / 4-0-26408H	626408
-9	POWER SUPPLY MODULE 9	N2165	ECI A/S	5-0-26409F / 4-0-26409F	626409
-10	AF AMPLIFIER MODULE (10)		ECI A/S	5-0-26410G / 4-0-26410I	626410
TR1	TRANSFORMER MAINS	100VA N2165/T2131	KOHSEL	6-0-26933A UI60/30-5049	22.513

FILTER UNIT MODULE 1		600/1200W HF SSB	ECI A/S	0-0-26401	726401
POSITION	DESCRIPTION		MANUFACTOR	TYPE	PART NO.
C1-1	CAPACITOR	267pF	ECI A/S	3-0-26341	726341
C2-1	CAPACITOR	365pF	ECI A/S	3-0-26340	726340
C3-1	CAPACITOR	1.86nF	ECI A/S	3-0-26342	726342
C4-1	CAPACITOR	2.06nF	ECI A/S	3-0-26343	726343
C5-1	CAPACITOR	1.86nF	ECI A/S	3-0-26342	726342
L1-1	INDUCTOR	2,14uH	ECI A/S	6-0-23163D	400311
L2-1	INDUCTOR	1,46uH	ECI A/S	6-0-23164C	400312
L3-1	INDUCTOR	4,07uH	ECI A/S	6-0-23186	400334
L4-1	INDUCTOR	9,3uH	ECI A/S	6-0-26370	400533
L5-1	INDUCTOR	9,3uH	ECI A/S	6-0-26370	400533
L6-1	INDUCTOR	4,07uH	ECI A/S	6-0-23186	400334
R1-1	RESISTOR	100ohm 5% 50W	ARCOL	NHS-50-100-5% & Lmax=250nH/25MHz	06.376

FILTER UNIT MODULE 2		600/1200W HF SSB	ECI A/S	0-0-26402	726402
POSITION	DESCRIPTION		MANUFACTOR	TYPE	PART NO.
C1-2	CAPACITOR	178pF	ECI A/S	3-0-26344	726344
C2-2	CAPACITOR	244pF	ECI A/S	3-0-26345	726345
C3-2	CAPACITOR	1.14nF	ECI A/S	3-0-26346	726346
C4-2	CAPACITOR	1.27nF	ECI A/S	3-0-26347	726347
C5-2	CAPACITOR	1.14nF	ECI A/S	3-0-26346	726346
L1-2	INDUCTOR	1,56uH	ECI A/S	6-0-23165C	400313
L2-2	INDUCTOR	1,11uH	ECI A/S	6-0-23166C	400314
L3-2	INDUCTOR	3,8uH	ECI A/S	6-0-26371	400534
L4-2	INDUCTOR	6,6uH	ECI A/S	6-0-26372A	400535
L5-2	INDUCTOR	6,6uH	ECI A/S	6-0-26372A	400535
L6-2	INDUCTOR	3,8uH	ECI A/S	6-0-26371	400534
R1-2	RESISTOR	100ohm 5% 50W	ARCOL	NHS-50-100-5% & Lmax=250nH/25MHz	06.376

FILTER UNIT MODULE 3		600/1200W HF SSB	ECI A/S	0-0-26403	726403
POSITION	DESCRIPTION		MANUFACTOR	TYPE	PART NO.
C1-3	CAPACITOR	109pF	ECI A/S	3-0-26348	726348
C2-3	CAPACITOR	150pF	ECI A/S	3-0-26349	726349
C3-3	CAPACITOR	720pF	ECI A/S	3-0-26350A	726350
C4-3	CAPACITOR	780pF	ECI A/S	3-0-26351A	726351
C5-3	CAPACITOR	720pF	ECI A/S	3-0-26350A	726350
L1-3	INDUCTOR	1,11uH	ECI A/S	6-0-23167C	400315
L2-3	INDUCTOR	755nH	ECI A/S	6-0-23168B	400316
L3-3	INDUCTOR	1,9uH	ECI A/S	6-0-26377B	400540
L4-3	INDUCTOR	3,7uH	ECI A/S	6-0-26384B	400547
L5-3	INDUCTOR	3,7uH	ECI A/S	6-0-26384B	400547
L6-3	INDUCTOR	1,9uH	ECI A/S	6-0-26377B	400540
R1-3	RESISTOR	100ohm 5% 50W	ARCOL	NHS-50-100-5% & Lmax=250nH/25MHz	06.376

FILTER UNIT MODULE 4		600/1200W HF SSB	ECI A/S	0-0-26404	726404
POSITION	DESCRIPTION		MANUFACTOR	TYPE	PART NO.
C1-4	CAPACITOR	67pF	ECI A/S	3-0-26353	726353
C2-4	CAPACITOR	91pF	ECI A/S	3-0-26352	726352
C3-4	CAPACITOR	429pF	ECI A/S	3-0-26354	726354
C4-4	CAPACITOR	475pF	ECI A/S	3-0-26355	726355
C5-4	CAPACITOR	429pF	ECI A/S	3-0-26354	726354
L1-4	INDUCTOR	0,93uH	ECI A/S	6-0-26373A	400536
L2-4	INDUCTOR	0,67uH	ECI A/S	6-0-26374	400537
L3-4	INDUCTOR	1,57uH	ECI A/S	6-0-26375B	400538
L4-4	INDUCTOR	1,72uH	ECI A/S	6-0-26376B	400539
L5-4	INDUCTOR	1,9uH	ECI A/S	6-0-26377B	400540
L6-4	INDUCTOR	1,1uH	ECI A/S	6-0-26378B	400541
R1-4	RESISTOR	100ohm 5% 50W	ARCOL	NHS-50-100-5% & Lmax=250nH/25MHz	06.376

FILTER UNIT MODULE 5		600/1200W HF SSB	ECI A/S	0-0-26405	726405
POSITION	DESCRIPTION		MANUFACTOR	TYPE	PART NO.
C1-5	CAPACITOR	41pF	ECI A/S	3-0-26356	726356
C2-5	CAPACITOR	56pF	ECI A/S	3-0-26357	726357
C3-5	CAPACITOR	255pF	ECI A/S	3-0-26358	726358
C4-5	CAPACITOR	282pF	ECI A/S	3-0-26359	726359
C5-5	CAPACITOR	255pF	ECI A/S	3-0-26358	726358
L1-5	INDUCTOR	0,73uH	ECI A/S	6-0-26379	400542
L2-5	INDUCTOR	0,5uH	ECI A/S	6-0-26537	400551
L3-5	INDUCTOR	0,92uH	ECI A/S	6-0-26380B	400543
L4-5	INDUCTOR	1,2uH	ECI A/S	6-0-23178B	400326
L5-5	INDUCTOR	1,2uH	ECI A/S	6-0-23178B	400326
L6-5	INDUCTOR	0,65uH	ECI A/S	9-0-23177B	400325
R1-5	RESISTOR	100ohm 5% 50W	ARCOL	NHS-50-100-5% & Lmax=250nH/25MHz	06.376

FILTER UNIT MODULE 6		600/1200W HF SSB	ECI A/S	0-0-26406	726406
POSITION	DESCRIPTION		MANUFACTOR	TYPE	PART NO.
C1-6	CAPACITOR	25pF	ECI A/S	3-0-26360A	726360
C2-6	CAPACITOR	35pF	ECI A/S	3-0-26361A	726361
C3-6	CAPACITOR	147pF	ECI A/S	3-0-26362	726362
C4-6	CAPACITOR	163pF	ECI A/S	3-0-26363	726363
C5-6	CAPACITOR	147pF	ECI A/S	3-0-26362	726362
L1-6	INDUCTOR	214nH	ECI A/S	6-0-23173E	400321
L2-6	INDUCTOR	146nH	ECI A/S	6-0-23174C	400322

POSITION	DESCRIPTION		MANUFACTURER	TYPE	PART NO.
L3-6	INDUCTOR	0,53uH	ECI A/S	6-0-26381B	400544
L4-6	INDUCTOR	0,65uH	ECI A/S	9-0-23177B	400325
L5-6	INDUCTOR	0,85uH	ECI A/S	6-0-26382B	400545
L6-6	INDUCTOR	0,52uH	ECI A/S	6-0-23179C	400327
R1-6	NON INDUCTIVE	RESISTOR 100R-25W	ECI A/S	3-0-25655	725655

FILTER SWITCH MODULE 7		T2131/35	ECI A/S	5-0-27147C / 4-0-27147D	627147
------------------------	--	----------	---------	-------------------------	--------

POSITION	DESCRIPTION		MANUFACTURER	TYPE	PART NO.
C1-7	CAPACITOR MKT	330nF 10% 63VDC	ERO	MKT 1826-433/06 5G	11.189
C2-7	CAPACITOR CERAMIC	12pF 5% NPO 500VDC	KCK	RT-HM60-SK CH 120 J	15.575
C3-7	CAPACITOR CERAMIC	82pF 5% N150 50VDC	KCK	RT-HE70-SK PH 820 J	15.126
C4-7	CAPACITOR CERAMIC	82pF 5% N150 50VDC	KCK	RT-HE70-SK PH 820 J	15.126
C5-7	CAPACITOR TRIMMING	5-60pF PTFE Ø9	DAU	109.4901.060	17.210
C6-7	CAPACITOR MKT	10nF 20% 100VDC	PHILIPS	2222 370 38103	11.168
C7-7	CAPACITOR MKT	2n2F 10% 400VDC	ERO	MKT 1818-222/63 5-G	11.143
C9-7	CAPACITOR MKT	220nF 10% 63VDC	PHILIPS	2222 370 78224	11.095
C10-7	CAPACITOR MKT	10nF 20% 100VDC	PHILIPS	2222 370 38103	11.168
C11-7	CAPACITOR MKT	10nF 20% 100VDC	PHILIPS	2222 370 38103	11.168
C12-7	CAPACITOR MKT	2n2F 10% 400VDC	ERO	MKT 1818-222/63 5-G	11.143
C14-7	CAPACITOR MKT	220nF 10% 63VDC	PHILIPS	2222 370 78224	11.095
C15-7	CAPACITOR MKT	10nF 20% 100VDC	PHILIPS	2222 370 38103	11.168
C16-7	CAPACITOR MKT	10nF 20% 100VDC	PHILIPS	2222 370 38103	11.168
C19-7	CAPACITOR MKT	330nF 10% 63VDC	ERO	MKT 1826-433/06 5G	11.189
C21-7	CAPACITOR CERAMIC	10nF -20/+80% CL2 50VDC	KCK	RT-HE70 SK YF 103 Z	15.170
C22-7	CAPACITOR CERAMIC	10nF -20/+80% CL2 50VDC	KCK	RT-HE70 SK YF 103 Z	15.170
C23-7	CAPACITOR CERAMIC	10nF -20/+80% CL2 50VDC	KCK	RT-HE70 SK YF 103 Z	15.170
C24-7	CAPACITOR CERAMIC	10nF -20/+80% CL2 50VDC	KCK	RT-HE70 SK YF 103 Z	15.170
C25-7	CAPACITOR CERAMIC	10nF -20/+80% CL2 50VDC	KCK	RT-HE70 SK YF 103 Z	15.170
C26-7	CAPACITOR CERAMIC	10nF -20/+80% CL2 50VDC	KCK	RT-HE70 SK YF 103 Z	15.170
C27-7	CAPACITOR CERAMIC	10nF -20/+80% CL2 50VDC	KCK	RT-HE70 SK YF 103 Z	15.170
D1-7	DIODE SCHOTTKY BARRIER	70V/15mA 1N5711/5082-2800	SGS-THOMSON	1N5711	27.500
D2-7	DIODE SCHOTTKY BARRIER	70V/15mA 1N5711/5082-2800	SGS-THOMSON	1N5711	27.500
D3-7	DIODE SCHOTTKY BARRIER	70V/15mA 1N5711/5082-2800	SGS-THOMSON	1N5711	27.500
D4-7	DIODE HIGH SPEED	1N4448	PHILIPS	1N4448	25.147
D5-7	DIODE HIGH SPEED	1N4448	PHILIPS	1N4448	25.147
J3-7	RECEPTACLE	BNC RIGHT ANGLE	ROSENBERGER	51K-201-400 A4	78.443
J4-7	RECEPTACLE	BNC RIGHT ANGLE	ROSENBERGER	51K-201-400 A4	78.443
L1-7	CHOKE FIXED	39mH 5%	NEOSID	00 6122 43	20.218
P1-7	PLUG	2x7 POLES	3M	3598-6002 / 7614-6002 JL	78.254
P2-7	SOLDER LUG		OJD	01016C	82.006
P4-7	SOLDER LUG		OJD	01016C	82.006
P4-7	SOLDER LUG		OJD	01016C	82.006
P5-7	SOLDER LUG		OJD	01016C	82.006
P5-7	SOLDER LUG		OJD	01016C	82.006
P7-7	SOLDER LUG		OJD	01016C	82.006
P8-7	SOLDER LUG		OJD	01016C	82.006
P9-7	SOLDER LUG		OJD	01016C	82.006
P10-7	SOLDER LUG		OJD	01016C	82.006
P11-7	SOLDER LUG		OJD	01016C	82.006
P12-7	SOLDER LUG		OJD	01016C	82.006
P13-7	SOLDER LUG		OJD	01016C	82.006
P14-7	SOLDER LUG		OJD	01016C	82.006
P15-7	SOLDER LUG		OJD	01016C	82.006
P16-7	SOLDER LUG		OJD	01016C	82.006
P17-7	SOLDER LUG		OJD	01016C	82.006
P18-7	SOLDER LUG		OJD	01016C	82.006
P19-7	SOLDER LUG		OJD	01016C	82.006
P20-7	SOLDER LUG		OJD	01016C	82.006
P21-7	SOLDER LUG		OJD	01016C	82.006
R2-7	RESISTOR PMF	33k OHM 5% 2W	PHILIPS	2322 194 13333	04.229
R4-7	RESISTOR MF	1k2 OHM 5% 0.33W	PHILIPS	2322 187 73122	02.474
R5-7	RESISTOR MF	22k OHM 5% 0.33W	PHILIPS	2322 187 73223	02.504
R6-7	RESISTOR MF	100 OHM 5% 0.33W	PHILIPS	2322 187 73101	02.448
R7-7	RESISTOR MF	100 OHM 5% 0.33W	PHILIPS	2322 187 73101	02.448
R8-7	RESISTOR MF	100 OHM 5% 0.33W	PHILIPS	2322 187 73101	02.448
R9-7	RESISTOR MF	100 OHM 5% 0.33W	PHILIPS	2322 187 73101	02.448
R10-7	RESISTOR MF	100 OHM 5% 0.33W	PHILIPS	2322 187 73101	02.448

POSITION	DESCRIPTION		MANUFACTOR	TYPE	PART NO.
R11-7	RESISTOR MF	5k6 OHM 5% 0.33W	PHILIPS	2322 187 73562	02.490
R12-7	RESISTOR MF	5k6 OHM 5% 0.33W	PHILIPS	2322 187 73562	02.490
R13-7	RESISTOR MF	5k6 OHM 5% 0.33W	PHILIPS	2322 187 73562	02.490
R14-7	RESISTOR MF	22k OHM 5% 0.33W	PHILIPS	2322 187 73223	02.504
R17-7	RESISTOR MF	33k OHM 5% 0.33W	PHILIPS	2322 187 73333	02.508
R18-7	RESISTOR MF	33k OHM 5% 0.33W	PHILIPS	2322 187 73333	02.508
R19-7	RESISTOR MF	47 OHM 5% 0.33W	PHILIPS	2322 187 73479	02.440
R22-7	RESISTOR MF	33k OHM 5% 0.33W	PHILIPS	2322 187 73333	02.508
R23-7	RESISTOR MF	33k OHM 5% 0.33W	PHILIPS	2322 187 73333	02.508
R24-7	RESISTOR MF	47 OHM 5% 0.33W	PHILIPS	2322 187 73479	02.440
R31-7	RESISTOR WIRE WOUND	100 OHM 5% 25W NON INDUCT	ARCOL	NHS-25-100-5% & Lmax=17nH/25MHz	06.375
R32-7	RESISTOR WIRE WOUND	100 OHM 5% 25W NON INDUCT	ARCOL	NHS-25-100-5% & Lmax=17nH/25MHz	06.375
R33-7	RESISTOR WIRE WOUND	100 OHM 5% 25W NON INDUCT	ARCOL	NHS-25-100-5% & Lmax=17nH/25MHz	06.375
R34-7	RESISTOR WIRE WOUND	100 OHM 5% 25W NON INDUCT	ARCOL	NHS-25-100-5% & Lmax=17nH/25MHz	06.375
R35-7	RESISTOR WIRE WOUND	100 OHM 5% 25W NON INDUCT	ARCOL	NHS-25-100-5% & Lmax=17nH/25MHz	06.375
R36-7	RESISTOR WIRE WOUND	100 OHM 5% 25W NON INDUCT	ARCOL	NHS-25-100-5% & Lmax=17nH/25MHz	06.375
R37-7	RESISTOR WIRE WOUND	100 OHM 5% 25W NON INDUCT	ARCOL	NHS-25-100-5% & Lmax=17nH/25MHz	06.375
R38-7	RESISTOR WIRE WOUND	100 OHM 5% 25W NON INDUCT	ARCOL	NHS-25-100-5% & Lmax=17nH/25MHz	06.375
RE1-7	RELAY	12VDC 1SH. 8A.	SCHRACK	RY S 12 012	21.031
RE2-7	RELAY	12VDC 1SH. 8A.	SCHRACK	RY S 12 012	21.031
RE3-7	RELAY	12VDC 1SH. 8A.	SCHRACK	RY S 12 012	21.031
RE4-7	RELAY	12VDC 1SH. 8A.	SCHRACK	RY S 12 012	21.031
RE5-7	RELAY	12VDC 1SH. 8A.	SCHRACK	RY S 12 012	21.031
RE6-7	RELAY	12VDC 1SH. 8A.	SCHRACK	RY S 12 012	21.031
RE7-7	RELAY	12VDC 1SH. 8A.	SCHRACK	RY S 12 012	21.031
RE8-7	RELAY	12VDC 1SH. 8A.	SCHRACK	RY S 12 012	21.031
RE9-7	RELAY	12VDC 1SH. 8A.	SCHRACK	RY S 12 012	21.031
RE10-7	RELAY	12VDC 1SH. 8A.	SCHRACK	RY S 12 012	21.031
RE11-7	RELAY	12VDC 1SH. 8A.	SCHRACK	RY S 12 012	21.031
RE12-7	RELAY	12VDC 1SH. 8A.	SCHRACK	RY S 12 012	21.031
RE15-7	RELAY	12VDC 1SH. 8A.	SCHRACK	RY S 12 012	21.031
TR1-7	TRANSFORMER	TL501	ECI A/S	6-0-25786	400501
U1-7	QUAD OP.AMP.	324	NAT/SGS	LM324N	31.065

TX PROCESSOR MODULE (8)

T2131/35

ECI A/S

5-0-26408E / 4-0-26408H

626408

POSITION	DESCRIPTION		MANUFACTOR	TYPE	PART NO.
C1-8	CAPACITOR MKT	0.1uF 10% 63VDC	PHILIPS	2222 370 78104	11.136
C2-8	CAPACITOR MKT	0.1uF 10% 63VDC	PHILIPS	2222 370 78104	11.136
C3-8	CAPACITOR MKT	0.1uF 10% 63VDC	PHILIPS	2222 370 78104	11.136
C4-8	CAPACITOR MKT	0.1uF 10% 63VDC	PHILIPS	2222 370 78104	11.136
C5-8	CAPACITOR MKT	0.1uF 10% 63VDC	PHILIPS	2222 370 78104	11.136
C6-8	CAPACITOR MKT	0.1uF 10% 63VDC	PHILIPS	2222 370 78104	11.136
C7-8	CAPACITOR ELECTROLYTIC	4.7uF 20% 50VDC	ELNA	RJ2-50-V-4R7-M-T34	14.510
C8-8	CAPACITOR MKT	1000pF 10% 400VDC	ERO	MKT 1818-210/63 5-G	11.139
C9-8	CAPACITOR MKT	10nF 5% 63VDC	PHILIPS	2222 370 89103	11.134
C10-8	CAPACITOR ELECTROLYTIC	4.7uF 20% 50VDC	ELNA	RJ2-50-V-4R7-M-T34	14.510
C11-8	CAPACITOR MKT	0.1uF 10% 63VDC	PHILIPS	2222 370 78104	11.136
C12-8	CAPACITOR MKT	0.1uF 10% 63VDC	PHILIPS	2222 370 78104	11.136
C13-8	CAPACITOR MKT	0.1uF 10% 63VDC	PHILIPS	2222 370 78104	11.136
C14-8	CAPACITOR MKT	1000pF 10% 400VDC	ERO	MKT 1818-210/63 5-G	11.139
C15-8	CAPACITOR MKT	0.1uF 10% 63VDC	PHILIPS	2222 370 78104	11.136
C16-8	CAPACITOR MKT	0.1uF 10% 63VDC	PHILIPS	2222 370 78104	11.136
C17-8	CAPACITOR MKT	0.1uF 10% 63VDC	PHILIPS	2222 370 78104	11.136
C18-8	CAPACITOR MKT	0.1uF 10% 63VDC	PHILIPS	2222 370 78104	11.136
C19-8	CAPACITOR MKT	0.1uF 10% 63VDC	PHILIPS	2222 370 78104	11.136
C20-8	CAPACITOR MKT	0.1uF 10% 63VDC	PHILIPS	2222 370 78104	11.136
C21-8	CAPACITOR MKT	0.1uF 10% 63VDC	PHILIPS	2222 370 78104	11.136
C22-8	CAPACITOR MKT	0.1uF 10% 63VDC	PHILIPS	2222 370 78104	11.136
C23-8	CAPACITOR MKT	0.1uF 10% 63VDC	PHILIPS	2222 370 78104	11.136

POSITION	DESCRIPTION		MANUFACTURER	TYPE	PART NO.
C24-8	CAPACITOR MKT	0.1uF 10% 63VDC	PHILIPS	2222 370 78104	11.136
C25-8	CAPACITOR MKT	0.1uF 10% 63VDC	PHILIPS	2222 370 78104	11.136
C26-8	CAPACITOR MKT	0.1uF 10% 63VDC	PHILIPS	2222 370 78104	11.136
C27-8	CAPACITOR MKT	0.1uF 10% 63VDC	PHILIPS	2222 370 78104	11.136
C28-8	CAPACITOR MKT	0.1uF 10% 63VDC	PHILIPS	2222 370 78104	11.136
C29-8	CAPACITOR MKT	10nF 5% 63VDC	PHILIPS	2222 370 89103	11.134
C30-8	CAPACITOR MKT	1000pF 10% 400VDC	ERO	MKT 1818-210/63 5-G	11.139
C31-8	CAPACITOR MKT	0.1uF 10% 63VDC	PHILIPS	2222 370 78104	11.136
C32-8	CAPACITOR MKT	0.1uF 10% 63VDC	PHILIPS	2222 370 78104	11.136
C33-8	CAPACITOR MKT	0.1uF 10% 63VDC	PHILIPS	2222 370 78104	11.136
C34-8	CAPACITOR MKT	0.1uF 10% 63VDC	PHILIPS	2222 370 78104	11.136
C35-8	CAPACITOR ELECTROLYTIC	4.7uF 20% 50VDC	ELNA	RJ2-50-V-4R7-M-T34	14.510
C36-8	CAPACITOR MKT	0.1uF 10% 63VDC	PHILIPS	2222 370 78104	11.136
C37-8	CAPACITOR MKT	0.1uF 10% 63VDC	PHILIPS	2222 370 78104	11.136
C38-8	CAPACITOR MKT	0.1uF 10% 63VDC	PHILIPS	2222 370 78104	11.136
C39-8	CAPACITOR MKT	0.1uF 10% 63VDC	PHILIPS	2222 370 78104	11.136
C40-8	CAPACITOR MKT	0.1uF 10% 63VDC	PHILIPS	2222 370 78104	11.136
C41-8	CAPACITOR MKT	0.1uF 10% 63VDC	PHILIPS	2222 370 78104	11.136
C42-8	CAPACITOR MKT	0.1uF 10% 63VDC	PHILIPS	2222 370 78104	11.136
C43-8	CAPACITOR ELECTROLYTIC	22uF 20% 35VDC	ELNA	RJ2-35-V-220-M-F1	14.516
C44-8	CAPACITOR ELECTROLYTIC	10uF 20% 35VDC	ELNA	RJ2-35-V-100-M-T34(T58)	14.512
C45-8	CAPACITOR MKT	0.1uF 10% 63VDC	PHILIPS	2222 370 78104	11.136
C46-8	CAPACITOR ELECTROLYTIC	22uF 20% 35VDC	ELNA	RJ2-35-V-220-M-F1	14.516
C47-8	CAPACITOR ELECTROLYTIC	1000uF 20% 35VDC	SAMHWA ELEC.	SV-1000uF-35WV	14.655
C48-8	CAPACITOR MKT	0.1uF 10% 63VDC	PHILIPS	2222 370 78104	11.136
C49-8	CAPACITOR ELECTROLYTIC	22uF 20% 35VDC	ELNA	RJ2-35-V-220-M-F1	14.516
C50-8	CAPACITOR ELECTROLYTIC	10uF 20% 35VDC	ELNA	RJ2-35-V-100-M-T34(T58)	14.512
C51-8	CAPACITOR MKT	0.1uF 10% 63VDC	PHILIPS	2222 370 78104	11.136
C52-8	CAPACITOR ELECTROLYTIC	22uF 20% 35VDC	ELNA	RJ2-35-V-220-M-F1	14.516
C53-8	CAPACITOR ELECTROLYTIC	10uF 20% 35VDC	ELNA	RJ2-35-V-100-M-T34(T58)	14.512
C54-8	CAPACITOR ELECTROLYTIC	22uF 20% 35VDC	ELNA	RJ2-35-V-220-M-F1	14.516
C55-8	CAPACITOR MKT	0.1uF 10% 63VDC	PHILIPS	2222 370 78104	11.136
C56-8	CAPACITOR MKT	0.1uF 10% 63VDC	PHILIPS	2222 370 78104	11.136
C57-8	CAPACITOR MKT	0.1uF 10% 63VDC	PHILIPS	2222 370 78104	11.136
C58-8	CAPACITOR MKT	0.1uF 10% 63VDC	PHILIPS	2222 370 78104	11.136
C59-8	CAPACITOR MKT	0.1uF 10% 63VDC	PHILIPS	2222 370 78104	11.136
C60-8	CAPACITOR MKT	0.1uF 10% 63VDC	PHILIPS	2222 370 78104	11.136
C61-8	CAPACITOR ELECTROLYTIC	22uF 20% 35VDC	ELNA	RJ2-35-V-220-M-F1	14.516
C64-8	CAPACITOR MKT	0.1uF 10% 63VDC	PHILIPS	2222 370 78104	11.136
C65-8	CAPACITOR MKT	0.1uF 10% 63VDC	PHILIPS	2222 370 78104	11.136
C66-8	CAPACITOR CERAMIC	10nF -20/+80% CL2 50VDC	KCK	RT-HE70 SK YF 103 Z	15.170
C67-8	CAPACITOR CERAMIC	10nF -20/+80% CL2 50VDC	KCK	RT-HE70 SK YF 103 Z	15.170
D1-8	DIODE ZENER	5.1V 5% 0.4W BZX79C5V1	PHILIPS	BZX79C5V1	26.527
D2-8	DIODE ZENER	5.1V 5% 0.4W BZX79C5V1	PHILIPS	BZX79C5V1	26.527
D3-8	DIODE ZENER	5.1V 5% 0.4W BZX79C5V1	PHILIPS	BZX79C5V1	26.527
D4-8	DIODE HIGH SPEED	1N4448	PHILIPS	1N4448	25.147
D5-8	DIODE HIGH SPEED	1N4448	PHILIPS	1N4448	25.147
D6-8	DIODE HIGH SPEED	1N4448	PHILIPS	1N4448	25.147
D7-8	DIODE HIGH SPEED	1N4448	PHILIPS	1N4448	25.147
D8-8	DIODE HIGH SPEED	1N4448	PHILIPS	1N4448	25.147
D9-8	DIODE HIGH SPEED	1N4448	PHILIPS	1N4448	25.147
D10-8	DIODE HIGH SPEED	1N4448	PHILIPS	1N4448	25.147
D11-8	DIODE HIGH SPEED	1N4448	PHILIPS	1N4448	25.147
D12-8	DIODE HIGH SPEED	1N4448	PHILIPS	1N4448	25.147
D13-8	DIODE HIGH SPEED	1N4448	PHILIPS	1N4448	25.147
D14-8	DIODE HIGH SPEED	1N4448	PHILIPS	1N4448	25.147
D15-8	DIODE HIGH SPEED	1N4448	PHILIPS	1N4448	25.147
D16-8	DIODE HIGH SPEED	1N4448	PHILIPS	1N4448	25.147
D17-8	DIODE HIGH SPEED	1N4448	PHILIPS	1N4448	25.147
D18-8	DIODE HIGH SPEED	1N4448	PHILIPS	1N4448	25.147
D19-8	DIODE HIGH SPEED	1N4448	PHILIPS	1N4448	25.147
D20-8	DIODE HIGH SPEED	1N4448	PHILIPS	1N4448	25.147
D21-8	DIODE HIGH SPEED	1N4448	PHILIPS	1N4448	25.147
D22-8	DIODE HIGH SPEED	1N4448	PHILIPS	1N4448	25.147
D23-8	DIODE HIGH SPEED	1N4448	PHILIPS	1N4448	25.147
D24-8	DIODE HIGH SPEED	1N4448	PHILIPS	1N4448	25.147
D25-8	DIODE HIGH SPEED	1N4448	PHILIPS	1N4448	25.147
D26-8	DIODE HIGH SPEED	1N4448	PHILIPS	1N4448	25.147
D27-8	DIODE HIGH SPEED	1N4448	PHILIPS	1N4448	25.147
D28-8	DIODE ZENER	5.1V 5% 0.4W BZX79C5V1	PHILIPS	BZX79C5V1	26.527
D29-8	DIODE HIGH SPEED	1N4448	PHILIPS	1N4448	25.147

POSITION	DESCRIPTION		MANUFACTOR	TYPE	PART NO.
D30-8	DIODE HIGH SPEED	1N4448	PHILIPS	1N4448	25.147
D31-8	DIODE ZENER	3.9V 5% 0.4W BZX79C3V9	PHILIPS	BZX79C3V9	26.512
D32-8	DIODE HIGH SPEED	1N4448	PHILIPS	1N4448	25.147
D33-8	DIODE VOLTAGE REFERENCE	2.5V 1.5% LM385-2.5	MOTOROLA	LM385BZ-2.5	26.880
D34-8	DIODE HIGH SPEED	1N4448	PHILIPS	1N4448	25.147
D35-8	DIODE HIGH SPEED	1N4448	PHILIPS	1N4448	25.147
D36-8	DIODE RECTIFIER	1N4002 100V/1A	THOMSON	1N4002 (03/04/05/06/07)	25.100
D37-8	DIODE RECTIFIER	1N4002 100V/1A	THOMSON	1N4002 (03/04/05/06/07)	25.100
D38-8	DIODE RECTIFIER	1N4002 100V/1A	THOMSON	1N4002 (03/04/05/06/07)	25.100
D39-8	DIODE RECTIFIER	1N4002 100V/1A	THOMSON	1N4002 (03/04/05/06/07)	25.100
D40-8	DIODE RECTIFIER	1N4002 100V/1A	THOMSON	1N4002 (03/04/05/06/07)	25.100
D41-8	DIODE HIGH SPEED	1N4448	PHILIPS	1N4448	25.147
J1-8	SOCKET COAX FOR PCB	45 DEG. HORIZONTAL	TAIKO	TMP-J01X-A2	78.517
L1-8	CHOKE FIXED	180uH 5%	FASTRON	SMCC-181J-02	20.313
P1-8	MULTIPLUG	1/10" DIL SQ PINS 5x2 POL	AMP	826656-5	78.321
P2-8	PLUG	1/10" SIL SQ.PINS 2 POLES	AMP	0-826629-2 (0-826647-2)	78.322
P3-8	MULTI PLUG	2x8 POLES PCB VERSION	3M	3599-6002 / 7616-6002 JL	78.249
P4-8	PLUG	2x7 POLES	3M	3598-6002 / 7614-6002 JL	78.254
P5-8	MULTIPLUG	2x15 POLES PCB VERSION	3M	3531-6002 / 7630-6002 JL	78.253
Q1-8	TRANSISTOR AF	BC558 PNP TO-92	PHILIPS	BC558 (-A/-B/-C)	28.095
Q2-8	TRANSISTOR	BC640	PHILIPS	BC640	28.124
Q3-8	TRANSISTOR AF	NPN BC639 TO-92	PHILIPS	BC639	28.120
Q4-8	TRANSISTOR AF	NPN BC639 TO-92	PHILIPS	BC639	28.120
Q5-8	TRANSISTOR AF	NPN BC639 TO-92	PHILIPS	BC639	28.120
Q6-8	TRANSISTOR AF	NPN BC639 TO-92	PHILIPS	BC639	28.120
Q7-8	TRANSISTOR AF POWER	PNP TO-220	MOTOROLA	BD808 (BD810)	29.095
Q8-8	TRANSISTOR	BC640	PHILIPS	BC640	28.124
Q9-8	TRANSISTOR	BC640	PHILIPS	BC640	28.124
Q10-8	TRANSISTOR	BC640	PHILIPS	BC640	28.124
R1-8	RESISTOR MF	20k5 OHM 1% 0.6W	PHILIPS	2322 156 12053	03.478
R2-8	RESISTOR MF	1k96 OHM 1% 0.6W	PHILIPS	2322 156 11962	03.401
R3-8	RESISTOR MF	1M OHM 5% 0.33W	PHILIPS	2322 187 73105	02.544
R4-8	RESISTOR MF	10k OHM 5% 0.33W	PHILIPS	2322 187 73103	02.496
R5-8	RESISTOR MF	10k OHM 5% 0.33W	PHILIPS	2322 187 73103	02.496
R6-8	RESISTOR MF	12k OHM 5% 0.33W	PHILIPS	2322 187 73123	02.498
R7-8	RESISTOR MF	120k OHM 5% 0.33W	PHILIPS	2322 187 73124	02.522
R8-8	RESISTOR MF	2k7 OHM 5% 0.33W	PHILIPS	2322 187 73272	02.482
R9-8	RESISTOR MF	12k OHM 5% 0.33W	PHILIPS	2322 187 73123	02.498
R10-8	RESISTOR MF	1k2 OHM 5% 0.33W	PHILIPS	2322 187 73122	02.474
R11-8	RESISTOR MF	5.6 OHM 5% 0.33W	PHILIPS	2322 187 73568	02.418
R12-8	RESISTOR MF	5.6 OHM 5% 0.33W	PHILIPS	2322 187 73568	02.418
R13-8	RESISTOR MF	12k OHM 5% 0.33W	PHILIPS	2322 187 73123	02.498
R14-8	RESISTOR MF	10k OHM 5% 0.33W	PHILIPS	2322 187 73103	02.496
R15-8	RESISTOR MF	39k2 OHM 1% 0.6W	PHILIPS	2322 156 13923	03.439
R16-8	RESISTOR MF	10k0 OHM 1% 0.6W	PHILIPS	2322 156 11003	03.427
R17-8	RESISTOR MF	10k0 OHM 1% 0.6W	PHILIPS	2322 156 11003	03.427
R18-8	RESISTOR MF	1k00 OHM 1% 0.4W	PHILIPS	2322 156 11002	03.395
R19-8	RESISTOR MF	51R1 OHM 1% 0.6W	PHILIPS	2322 156 15119	03.370
R20-8	RESISTOR ARRAY	8x10k OHM 5% 1/8W	PANASONIC	EXB-F9E-103 J	08.630
R21-8	RESISTOR MF	5k1 OHM 5% 0.33W	PHILIPS	2322 187 73512	02.489
R22-8	RESISTOR MF	10k OHM 5% 0.33W	PHILIPS	2322 187 73103	02.496
R23-8	RESISTOR MF	5k1 OHM 5% 0.33W	PHILIPS	2322 187 73512	02.489
R24-8	RESISTOR MF	10k OHM 5% 0.33W	PHILIPS	2322 187 73103	02.496
R25-8	RESISTOR MF	10k OHM 5% 0.33W	PHILIPS	2322 187 73103	02.496
R26-8	RESISTOR MF	10k OHM 5% 0.33W	PHILIPS	2322 187 73103	02.496
R27-8	RESISTOR MF	10k OHM 5% 0.33W	PHILIPS	2322 187 73103	02.496
R28-8	RESISTOR MF	36k OHM 5% 0.33W	PHILIPS	2322 187 73363	02.509
R29-8	RESISTOR MF	10k OHM 5% 0.33W	PHILIPS	2322 187 73103	02.496
R30-8	RESISTOR MF	5k1 OHM 5% 0.33W	PHILIPS	2322 187 73512	02.489
R31-8	RESISTOR MF	22k OHM 5% 0.33W	PHILIPS	2322 187 73223	02.504
R32-8	RESISTOR MF	22k OHM 5% 0.33W	PHILIPS	2322 187 73223	02.504
R33-8	RESISTOR MF	10k OHM 5% 0.33W	PHILIPS	2322 187 73103	02.496
R34-8	RESISTOR MF	15k OHM 5% 0.33W	PHILIPS	2322 187 73153	02.500
R35-8	RESISTOR MF	10k OHM 5% 0.33W	PHILIPS	2322 187 73103	02.496
R36-8	RESISTOR MF PRECISION	10k0 OHM 0.1% 75mW	DRALORIC	SMA 0207S-TK25-10k0-0.1%	06.130
R37-8	RESISTOR MF PRECISION	10k0 OHM 0.1% 75mW	DRALORIC	SMA 0207S-TK25-10k0-0.1%	06.130
R38-8	RESISTOR MF	10k OHM 5% 0.33W	PHILIPS	2322 187 73103	02.496
R39-8	RESISTOR MF	39k OHM 5% 0.33W	PHILIPS	2322 187 73393	02.510
R40-8	RESISTOR	30 KOHM 1% 0.4W	*PHILIPS	2322 156 13003	03.460
R41-8	RESISTOR MF	2k0 OHM 1% 0.6W	* PHILIPS	2322 156 12002	03.403

POSITION	DESCRIPTION		MANUFACTURER	TYPE	PART NO.
R42-8	RESISTOR MF	90k9 OHM 1% 0.6W	PHILIPS	2322 156 19093	03.476
R43-8	RESISTOR	8.06 KOHM 1% 0.4W	*PHILIPS	2322 156 18062	03.422
R44-8	RESISTOR MF	100 OHM 5% 0.33W	PHILIPS	2322 187 73101	02.448
R45-8	RESISTOR MF	10k OHM 5% 0.33W	PHILIPS	2322 187 73103	02.496
R46-8	RESISTOR MF	5k1 OHM 5% 0.33W	PHILIPS	2322 187 73512	02.489
R47-8	RESISTOR MF	10k OHM 5% 0.33W	PHILIPS	2322 187 73103	02.496
R48-8	RESISTOR MF	1k0 OHM 5% 0.33W	PHILIPS	2322 187 73102	02.472
R49-8	RESISTOR MF	10k OHM 5% 0.33W	PHILIPS	2322 187 73103	02.496
R50-8	RESISTOR MF	10k OHM 5% 0.33W	PHILIPS	2322 187 73103	02.496
R51-8	RESISTOR MF	10k0 OHM 1% 0.6W	PHILIPS	2322 156 11003	03.427
R52-8	RESISTOR MF	1k87 OHM 1% 0.6W	PHILIPS	2322 156 11872	03.474
R53-8	RESISTOR MF	10k OHM 5% 0.33W	PHILIPS	2322 187 73103	02.496
R54-8	RESISTOR MF	1k0 OHM 5% 0.33W	PHILIPS	2322 187 73102	02.472
R55-8	RESISTOR MF	1k0 OHM 5% 0.33W	PHILIPS	2322 187 73102	02.472
R56-8	RESISTOR MF	3k92 OHM 1% 0.6W	PHILIPS	2322 156 13922	03.409
R57-8	RESISTOR MF	10k0 OHM 1% 0.6W	PHILIPS	2322 156 11003	03.427
R58-8	RESISTOR MF	3k92 OHM 1% 0.6W	PHILIPS	2322 156 13922	03.409
R59-8	RESISTOR MF	2k0 OHM 1% 0.6W	* PHILIPS	2322 156 12002	03.403
R60-8	RESISTOR MF	3k92 OHM 1% 0.6W	PHILIPS	2322 156 13922	03.409
R61-8	RESISTOR MF	5k1 OHM 5% 0.33W	PHILIPS	2322 187 73512	02.489
R62-8	RESISTOR MF	2k2 OHM 5% 0.33W	PHILIPS	2322 187 73222	02.480
R63-8	RESISTOR MF	10k OHM 5% 0.33W	PHILIPS	2322 187 73103	02.496
R64-8	RESISTOR MF	8k2 OHM 5% 0.33W	PHILIPS	2322 187 73822	02.494
R65-8	RESISTOR MF PRECISION	2k58 OHM 0.1% 75mW	DRALORIC	SMA 0207S-TK25-2k58-0.1%	06.120
R66-8	RESISTOR MF PRECISION	499 OHM 0.1% 75mW	DRALORIC	SMA 0207S-TK25-499R-0.1%	06.105
R67-8	RESISTOR MF	10k OHM 5% 0.33W	PHILIPS	2322 187 73103	02.496
R68-8	RESISTOR MF	8k2 OHM 5% 0.33W	PHILIPS	2322 187 73822	02.494
R69-8	RESISTOR MF PRECISION	499 OHM 0.1% 75mW	DRALORIC	SMA 0207S-TK25-499R-0.1%	06.105
R70-8	RESISTOR MF PRECISION	642 OHM 0.1% 75mW	DRALORIC	SMA 0207S-TK25-642R-0.1%	06.110
R71-8	RESISTOR MF	10k OHM 5% 0.33W	PHILIPS	2322 187 73103	02.496
R72-8	RESISTOR MF	100 OHM 5% 0.33W	PHILIPS	2322 187 73101	02.448
R73-8	RESISTOR MF	100 OHM 5% 0.33W	PHILIPS	2322 187 73101	02.448
R74-8	RESISTOR MF	100 OHM 5% 0.33W	PHILIPS	2322 187 73101	02.448
R75-8	RESISTOR MF	3k3 OHM 5% 0.33W	PHILIPS	2322 187 73332	02.484
R76-8	RESISTOR MF	10k OHM 5% 0.33W	PHILIPS	2322 187 73103	02.496
R77-8	RESISTOR MF	100 OHM 5% 0.33W	PHILIPS	2322 187 73101	02.448
R78-8	RESISTOR ARRAY	8x10k OHM 5% 1/8W	PANASONIC	EXB-F9E-103 J	08.630
R79-8	RESISTOR MF	20k OHM 5% 0.33W	PHILIPS	2322 187 73203	02.503
R80-8	RESISTOR MF	100 OHM 5% 0.33W	PHILIPS	2322 187 73101	02.448
U1-8	PROGRAMMED PROM U1-8	T2131/35	ECI	0-0-27203 / C10960-6DC5	727203
U2-8	NAND SCHMIDT TRIGGER	74HC132	TEXAS	74HC132	34.521
U3-8	MASTER PROCESSOR UNIT	8 BIT SERIAL INTERFACE	HITACHI	HD63B03YP	32.575
U4-8	uC SUPERVISORY CIRCUIT	MAX 690	MAXIM	MAX 690 CPA (EJA-MJA)	32.585
U5-8	QUAD 2-INP.POS.AND GATE	74HC08	TEXAS	SN74HC08N	34.517
U6-8	DUAL OPERATIONAL AMP.	MC1458/LM1458	MOTOROLA	MC1458CP1	31.215
U7-8	3 to 8 LINE DECODER		MOTOROLA	MC74HC237N	34.550
U8-8	EEPROM 1k BIT SERIAL	93C46	EXEL	XLS93C46P-3	32.709
U9-8	EEPROM 1k BIT SERIAL	93C46	EXEL	XLS93C46P-3	32.709
U10-8	8 BIT SHIFT REG.SERIAL IO	74HC595	MOTOROLA	MC74HC595P	34.502
U11-8	8 BIT SHIFT REG.SERIAL IO	74HC595	MOTOROLA	MC74HC595P	34.502
U12-8	8 BIT SHIFT REG.SERIAL IO	74HC595	MOTOROLA	MC74HC595P	34.502
U13-8	INTEGRATED CIRCUIT	ADC 0838 CCN	NATIONAL	ADC 0838 CCN	32.800
U14-8	DARL.DRIVERS HI.CURR/VOLT	ULN2003/MC1413/L203	TEXAS	ULN2003A	31.077
U15-8	DUAL OPERATIONAL AMP.	MC1458/LM1458	MOTOROLA	MC1458CP1	31.215
U16-8	INTEGRATED CIRCUIT	TL072CP	TEXAS	TL072CP	31.710
U17-8	8 BIT SHIFT REG.SERIAL IO	74HC595	MOTOROLA	MC74HC595P	34.502
U18-8	SOURCE DRIVER 8-UNIT	50V/500mA	SPRAGUE	UDN 2981 A	32.791
U19-8	8 BIT SHIFT REG.SERIAL IO	74HC595	MOTOROLA	MC74HC595P	34.502
U20-8	SOURCE DRIVER 8-UNIT	50V/500mA	SPRAGUE	UDN 2981 A	32.791
U21-8	DARL.DRIVERS HI.CURR/VOLT	ULN2003/MC1413/L203	TEXAS	ULN2003A	31.077
U22-8	DARL.DRIVERS HI.CURR/VOLT	ULN2003/MC1413/L203	TEXAS	ULN2003A	31.077
U23-8	ANALOG MULTIPLEXER	MC14053BCP	MOTOROLA*	MC14053BCP	33.201
U24-8	DUAL OPERATIONAL AMP.	MC1458/LM1458	MOTOROLA	MC1458CP1	31.215
U25-8	POS. VOLTAGE REG. 5V/1A	MCT7805-MC7805-LM340T-5.0	MOTOROLA	MCT7805CT (MCT7805BT)	31.250
U26-8	POS. VOLTAGE REG. 5V/1A	MCT7805-MC7805-LM340T-5.0	MOTOROLA	MCT7805CT (MCT7805BT)	31.250
U27-8	POS. VOLTAGE REG. 15V/1A	MCT7815-MC7815-LM340T-15	MOTOROLA	MCT7815CT (MCT7815BT)	31.090
U28-8	NEG. VOLTAGE REG. FIXED	-15V 5% 0.1A 79L15AC	MOTOROLA	MC79L15ACP	31.143
U29-8	NEG. VOLTAGE REG. FIXED	-5V/1A 7905CT/LM320T-5.0	MOTOROLA	MC7905CT	31.071
XR1-8	CERAMIC RESONATOR		MURATA	CST 800MT-TR	41.505

POWER SUPPLY MODULE 9		N2165	ECI A/S	5-0-26409F / 4-0-26409F	626409
POSITION	DESCRIPTION		MANUFACTOR	TYPE	PART NO.
C1-9	CAPACITOR ELECTROLYTIC	22uF 20% 35VDC	ELNA	RJ2-35-V-220-M-F1	14.516
C2-9	CAPACITOR MKT	1uF 10% 63VDC	ERO	MKT 1826-510/06 5-G	11.137
C3-9	CAPACITOR ELECTROLYTIC	2200uF -20/+50% 63VDC	PHILIPS	2222 021 48222	14.733
C4-9	CAPACITOR ELECTROLYTIC	2200uF -20/+50% 63VDC	PHILIPS	2222 021 48222	14.733
C5-9	CAPACITOR MKT	100nF 5% 63VDC	PHILIPS	2222 370 79104	11.135
C6-9	CAPACITOR ELECTROLYTIC	100uF 20% 10VDC	ELNA	RJ3-10-V-101-M-T34	14.607
C7-9	CAPACITOR MKT	10nF 20% 100VDC	PHILIPS	2222 370 38103	11.168
C8-9	CAPACITOR MKT	220nF 10% 63VDC	PHILIPS	2222 370 78224	11.095
C9-9	CAPACITOR MKT	100nF 5% 63VDC	PHILIPS	2222 370 79104	11.135
C10-9	CAPACITOR MKT	10nF 20% 100VDC	PHILIPS	2222 370 38103	11.168
C11-9	CAPACITOR MKT	10nF 20% 100VDC	PHILIPS	2222 370 38103	11.168
C12-9	CAPACITOR MKT	1uF 10% 63VDC	ERO	MKT 1826-510/06 5-G	11.137
C13-9	CAPACITOR MKT	1uF 10% 63VDC	ERO	MKT 1826-510/06 5-G	11.137
C14-9	CAPACITOR ELECTROLYTIC	22uF 20% 35VDC	ELNA	RJ2-35-V-220-M-F1	14.516
C15-9	CAPACITOR POLYSTYRENE	470pF 1% 630VDC	PHILIPS	2222 431 84701	10.429
C16-9	CAPACITOR CERAMIC	220pF 10% 500VDC CL2	KCK	RT-HM60-SK YB 221 K	16.090
C17-9	CAPACITOR CERAMIC	1nOF 10% CL2 500VDC	KCK	RT-HM60 SK YB 102 K	15.160
C18-9	CAPACITOR CERAMIC	220pF 10% 500VDC CL2	KCK	RT-HM60-SK YB 221 K	16.090
C19-9	CAPACITOR MKT	150nF 5% 50VDC	ERO	MKT 1826-415/06 4-G	11.181
C20-9	CAPACITOR ELECTROLYTIC	100uF -10/+50% 25VDC	ERO	EKM 00 CC 310 E G5	14.610
C21-9	CAPACITOR ELECTROLYTIC	100uF -10/+50% 25VDC	ERO	EKM 00 CC 310 E G5	14.610
C22-9	CAPACITOR ELECTROLYTIC	100uF -10/+50% 25VDC	ERO	EKM 00 CC 310 E G5	14.610
C23-9	CAPACITOR ELECTROLYTIC	100uF -10/+50% 25VDC	ERO	EKM 00 CC 310 E G5	14.610
C24-9	CAPACITOR ELECTROLYTIC	100uF -10/+50% 25VDC	ERO	EKM 00 CC 310 E G5	14.610
C25-9	CAPACITOR ELECTROLYTIC	100uF -10/+50% 25VDC	ERO	EKM 00 CC 310 E G5	14.610
C26-9	CAPACITOR MKT	100nF 10% 100VDC	ERO	MKT 1818-410/01 5-G	11.180
C27-9	CAPACITOR MKT	100nF 10% 100VDC	ERO	MKT 1818-410/01 5-G	11.180
C28-9	CAPACITOR MKT	100nF 10% 100VDC	ERO	MKT 1818-410/01 5-G	11.180
D1-9	DIODE ZENER	18V 5% 0.4W BZX79C18	PHILIPS	BZX79C18	26.564
D2-9	DIODE RECTIFIER	1N5402 200V/3A	PROMAX	1N5402	25.116
D3-9	DIODE RECTIFIER	1N5402 200V/3A	PROMAX	1N5402	25.116
D4-9	DIODE RECTIFIER	1N5402 200V/3A	PROMAX	1N5402	25.116
D5-9	DIODE RECTIFIER	1N5402 200V/3A	PROMAX	1N5402	25.116
D6-9	DIODE POWER	SCHOTTKY 45VDC/10A	PHILIPS	PBYR 1045	27.617
D7-9	ZENER DIODE 12V 5%	1.3W BZV85C12/BZX85C12	ITT	BZX85C12 TAPED IN CARTON	26.638
D8-9	DIODE FAST RECOVERY	600VDC/1A	PHILIPS	BYD 33 J	27.150
D9-9	DIODE FAST RECOVERY	600VDC/1A	PHILIPS	BYD 33 J	27.150
D10-9	DIODE FAST RECOVERY	600VDC/1A	PHILIPS	BYD 33 J	27.150
D11-9	DIODE FAST RECOVERY	600VDC/1A	PHILIPS	BYD 33 J	27.150
D12-9	DIODE FAST RECOVERY	400V/3A BYT03-400/MUR440	THOMSON	BYT 03-400 TAPED	25.212
D13-9	DIODE FAST RECOVERY	400V/3A BYT03-400/MUR440	THOMSON	BYT 03-400 TAPED	25.212
D14-9	DIODE FAST RECOVERY	400V/3A BYT03-400/MUR440	THOMSON	BYT 03-400 TAPED	25.212
D15-9	DIODE FAST RECOVERY	400V/3A BYT03-400/MUR440	THOMSON	BYT 03-400 TAPED	25.212
D16-9	DIODE FAST RECOVERY	400V/3A BYT03-400/MUR440	THOMSON	BYT 03-400 TAPED	25.212
D17-9	DIODE FAST RECOVERY	400V/3A BYT03-400/MUR440	THOMSON	BYT 03-400 TAPED	25.212
D18-9	DIODE SHUNT REGULATOR	PROGRAMMABLE TL431C	TEXAS	TL431CP	26.997
D19-9	DIODE HIGH SPEED	1N4448	PHILIPS	1N4448	25.147
L1-9	CHOKE	TL531	TRANS-ELECTRO	6-0-26309A	400531
L2-9	CHOKE FIXED	10mH/100mADC	TRADANIA	6-0-26623 Art.Nr: TD 6994.0	20.254
L3-9	CHOKE FIXED TOROIDAL	400uH/2A +20/-12%	ULVECO	2-2-0-400-2-R (DK11752) UDT.IFLG.SP Tg:0-0-26192	20.245
L4-9	CHOKE FIXED TOROIDAL	630uH/1A6 +20/-12.5%	ULVECO	Art.Nr: DK11-542 (2-1.6-630-1/SP Tg:26271)	20.244
L5-9	CHOKE FIXED TOROIDAL	630uH/1A6 +20/-12.5%	ULVECO	Art.Nr: DK11-542 (2-1.6-630-1/SP Tg:26271)	20.244
OC1-9	OPTO COUPLER	CNY17-2	MOTOROLA	CNY17-2	32.530
OC2-9	OPTO COUPLER	CNY17-2	MOTOROLA	CNY17-2	32.530
P1-9	PLUG 4 POLES		MOLEX	39-28-1043	78.216
P2-9	MULTIPLUG	2x3 POLES PCB VERSION	MOLEX	39-28-1063	78.217
Q1-9	TRANSISTOR AF POWER NPN	DARLINGTON BD645/BDX53	SGS	BDX53	29.122
Q2-9	TRANSISTOR AF	BC547B NPN TO-92	PHILIPS	BC547B	28.067
Q3-9	TRANS.POW.MOSFET N-CHANN.	100V/27A/85mOHM IRF540	MOTOROLA	IRF540	29.402
Q4-9	TRANS.POW.MOSFET N-CHANN.	100V/27A/85mOHM IRF540	MOTOROLA	IRF540	29.402
R1-9	RESISTOR MF	820 OHM 5% 0.33W	PHILIPS	2322 187 73821	02.470
R2-9	RESISTOR MF	4k7 OHM 5% 0.33W	PHILIPS	2322 187 73472	02.488
R3-9	RESISTOR MF	10k0 OHM 1% 0.6W	PHILIPS	2322 156 11003	03.427

POSITION	DESCRIPTION		MANUFACTOR	TYPE	PART NO.
R4-9	RESISTOR MF	13k3 OHM 1% 0.6W	PHILIPS	2322 156 11333	03.473
R5-9	RESISTOR MF	2k2 OHM 5% 0.33W	PHILIPS	2322 187 73222	02.480
R6-9	RESISTOR MF	270 OHM 5% 0.33W	PHILIPS	2322 187 73271	02.458
R7-9	RESISTOR MF	10k OHM 5% 0.33W	PHILIPS	2322 187 73103	02.496
R8-9	RESISTOR MF	10k OHM 5% 0.33W	PHILIPS	2322 187 73103	02.496
R9-9	RESISTOR MF	100k OHM 1% 0.6W	* PHILIPS	2322 156 11004	03.477
R10-9	RESISTOR MF	680 OHM 5% 0.33W	PHILIPS	2322 187 73681	02.468
R11-9	PRESET CERMET	1k0 OHM 10% 0.5W	BOURNS	3386P-1-102	07.886
R12-9	RESISTOR MF	6k8 OHM 5% 0.33W	PHILIPS	2322 187 73682	02.492
R13-9	RESISTOR MF	100 OHM 5% 0.33W	PHILIPS	2322 187 73101	02.448
R14-9	RESISTOR MF	100 OHM 5% 0.33W	PHILIPS	2322 187 73101	02.448
R15-9	RESISTOR MF	100 OHM 5% 0.33W	PHILIPS	2322 187 73101	02.448
R16-9	RESISTOR MF	22k OHM 5% 0.33W	PHILIPS	2322 187 73223	02.504
R17-9	RESISTOR WW	R180 OHM 5% 2W	MODULOHM	R18-J-2W-E-1	06.220
R18-9	RESISTOR WW	R180 OHM 5% 2W	MODULOHM	R18-J-2W-E-1	06.220
R19-9	RESISTOR MF	470 OHM 5% 0.33W	PHILIPS	2322 187 73471	02.464
R20-9	RESISTOR MF	22k OHM 5% 0.33W	PHILIPS	2322 187 73223	02.504
R21-9	RESISTOR MF	1k0 OHM 5% 0.33W	PHILIPS	2322 187 73102	02.472
R22-9	RESISTOR MF	2k2 OHM 5% 0.33W	PHILIPS	2322 187 73222	02.480
R23-9	RESISTOR MF	240 OHM 5% 0.33W	PHILIPS	2322 187 73241	02.457
R24-9	RESISTOR MF	1k0 OHM 5% 0.33W	PHILIPS	2322 187 73102	02.472
R25-9	RESISTOR MF	4k7 OHM 5% 0.33W	PHILIPS	2322 187 73472	02.488
R26-9	RESISTOR MF	100k OHM 5% 0.33W	PHILIPS	2322 187 73104	02.520
R27-9	RESISTOR MF	13k3 OHM 1% 0.6W	PHILIPS	2322 156 11333	03.473
R28-9	RESISTOR MF	1k87 OHM 1% 0.6W	PHILIPS	2322 156 11872	03.474
R29-9	RESISTOR PMF	120 OHM 5% 2W	PHILIPS	2322 191 31201	04.178
R30-9	RESISTOR PMF	390 OHM 5% 2W	PHILIPS	2322 194 13391	04.189
R31-9	RESISTOR PMF	390 OHM 5% 2W	PHILIPS	2322 194 13391	04.189
RE1-9	RELAY	24VDC 1MAKE 16A.	SIEMENS	V23056-A0105-A402	21.027
RE2-9	RELAY	24VDC 1MAKE 16A.	SIEMENS	V23056-A0105-A402	21.027
TR1-9	TRANSFORMER SMPS	35x40x43mm	TRADANIA	6-0-26620A Art.Nr: TD 6993.0	22.173
U1-9	CURRENT MODE PWM CONTROL.	UC3846	UNITRODE	UC3846	31.486

AF AMPLIFIER MODULE (10)

ECI A/S

5-0-26410G / 4-0-26410I

626410

POSITION	DESCRIPTION		MANUFACTOR	TYPE	PART NO.
C1-10	CAPACITOR CERAMIC	1nOF 10% CL2 500VDC	KCK	RT-HM60 SK YB 102 K	15.160
C2-10	CAPACITOR CERAMIC	1nOF 10% CL2 500VDC	KCK	RT-HM60 SK YB 102 K	15.160
C3-10	CAPACITOR CERAMIC	1nOF 10% CL2 500VDC	KCK	RT-HM60 SK YB 102 K	15.160
C4-10	CAPACITOR ELECTROLYTIC	10uF 20% 35VDC	ELNA	RJ2-35-V-100-M-T34(T58)	14.512
C5-10	CAPACITOR ELECTROLYTIC	10uF 20% 35VDC	ELNA	RJ2-35-V-100-M-T34(T58)	14.512
C6-10	CAPACITOR ELECTROLYTIC	22uF 20% 35VDC	ELNA	RJ2-35-V-220-M-F1	14.516
C7-10	CAPACITOR MKT	470nF 5% 63VDC	ERO	MKT 1826-447/06 4-G	11.187
C9-10	CAPACITOR MKT	330nF 10% 63VDC	ERO	MKT 1826-433/06 5G	11.189
C10-10	CAPACITOR ELECTROLYTIC	470uF -20/+50% 40VDC	ELNA	RJ3-50-471-M-F	14.649
C11-10	CAPACITOR CERAMIC	1nOF 10% CL2 500VDC	KCK	RT-HM60 SK YB 102 K	15.160
C12-10	CAPACITOR CERAMIC	1nOF 10% CL2 500VDC	KCK	RT-HM60 SK YB 102 K	15.160
C13-10	CAPACITOR MKT	470nF 10% 100VDC	PHILIPS	2222 371 28474	11.049
C14-10	CAPACITOR MKT	470nF 10% 100VDC	PHILIPS	2222 371 28474	11.049
D1-10	DIODE HIGH SPEED	1N4448	PHILIPS	1N4448	25.147
D2-10	DIODE RECTIFIER	1N4002 100V/1A	THOMSON	1N4002 (03/04/05/06/07)	25.100
D3-10	DIODE RECTIFIER	1N4002 100V/1A	THOMSON	1N4002 (03/04/05/06/07)	25.100
FP1-10	FERRITE BEAD INDUCTOR		MURATA	BLO1RN1-A62T5	35.188
FP2-10	FERRITE BEAD INDUCTOR		MURATA	BLO1RN1-A62T5	35.188
P1-10	PLUG	2 POLES	AMP	0-826375-2	78.102
P2-10	PLUG	2x7 POLES	3M	3598-6002 / 7614-6002 JL	78.254
P3-10	PLUG	2x5 POLES	3M	3654-6002 / 7610-6002 JL	78.251
Q1-10	TRANSISTOR AF	BC548 NPN TO-92	PHILIPS	BC548 (-A/-B/-C)	28.070
R1-10	RESISTOR MF	6k8 OHM 5% 0.33W	PHILIPS	2322 187 73682	02.492
R2-10	RESISTOR MF	10k OHM 5% 0.33W	PHILIPS	2322 187 73103	02.496
R3-10	RESISTOR MF	120k OHM 5% 0.33W	PHILIPS	2322 187 73124	02.522
R4-10	RESISTOR MF	820 OHM 5% 0.33W	PHILIPS	2322 187 73821	02.470
R5-10	RESISTOR MF	220k OHM 5% 0.33W	PHILIPS	2322 187 73224	02.528
R6-10	RESISTOR MF	100k OHM 5% 0.33W	PHILIPS	2322 187 73104	02.520
R7-10	RESISTOR MF	470 OHM 5% 0.33W	PHILIPS	2322 187 73471	02.464
R8-10	RESISTOR MF	33k OHM 5% 0.33W	PHILIPS	2322 187 73333	02.508
R9-10	RESISTOR MF	1 OHM 5% 0.4W	PHILIPS	2322 181 53108	01.125

6 PARTS LIST

PART II

<u>POSITION</u>	<u>DESCRIPTION</u>		<u>MANUFACTOR</u>	<u>TYPE</u>	<u>PART NO.</u>
R10-10	RESISTOR MF	1k0 OHM 5% 0.33W	PHILIPS	2322 187 73102	02.472
RE1-10	RELAY	24VDC 2SH. 2A	OMRON	G5V-2-24 VDC	21.327
TR1-10	TRAFO AF	1:1 600 OHMS	TDK	L04EE13-C10153	22.500
U1-10	AF POWER AMPLIFIER	TDA 2030 VERT.	THOMSON	TDA 2030 V	31.483

TECHNICAL MANUAL FOR POWER AMPLIFIER UNIT 600W
(T2131) PART NO. 726393**CONTENTS**

1	GENERAL INFORMATION	
1.1	INTRODUCTION	1-1
1.2	PRINCIPLE OF OPERATION	1-1
2	INSTALLATION	
2.1	ELECTRICAL CONNECTION AND ASSEMBLING	2-1
3	SERVICE	
3.1	ALIGNMENT INSTRUCTIONS	3-1
3.2	PROPOSAL FOR NECESSARY MEASURING INSTRUMENTS	3-1
3.3	TROUBLE SHOOTING	3-1
3.4	ADJUSTMENT PROCEDURE	3-2
3.5	NECESSARY ADJUSTMENTS AFTER REPAIR	3-2
3.6	PERFORMANCE CHECK	3-2
4	MECHANICAL DESCRIPTION	
4.1	MECHANICAL ASSEMBLING / DISASSEMBLING AND UNITS LOCATION	4-1
5	CIRCUIT DESCRIPTION AND SCHEMATIC DIAGRAMS	
5.1	POWER AMPLIFIER (MODULE 11) PART NO. 626411	5-1
5.2	PROTECTION (MODULE 19) PART NO. 626419	5-5
6	PARTS LISTS	

CONTENTS

1	GENERAL INFORMATION	1-1
1.1	INTRODUCTION	1-1
1.2	PRINCIPLE OF OPERATION	1-1

1 GENERAL INFORMATION

1.1 INTRODUCTION

This section gives you all necessary information to make service of this unit down to component level.

1.2 PRINCIPLE OF OPERATION

The power amplifier has three stages of amplifiers giving a total gain of approx. 43 dB and a power output of 650W PEP.

The coupling between the stages is done by impedance matching transformers. The input and output impedance is 50 ohm.

The power amplifier requires two supply voltages, 28V for the predriver and driver, 42V for the output amplifier. Both supplied from N2170 or N2171.

The amplifier has forced air cooling.

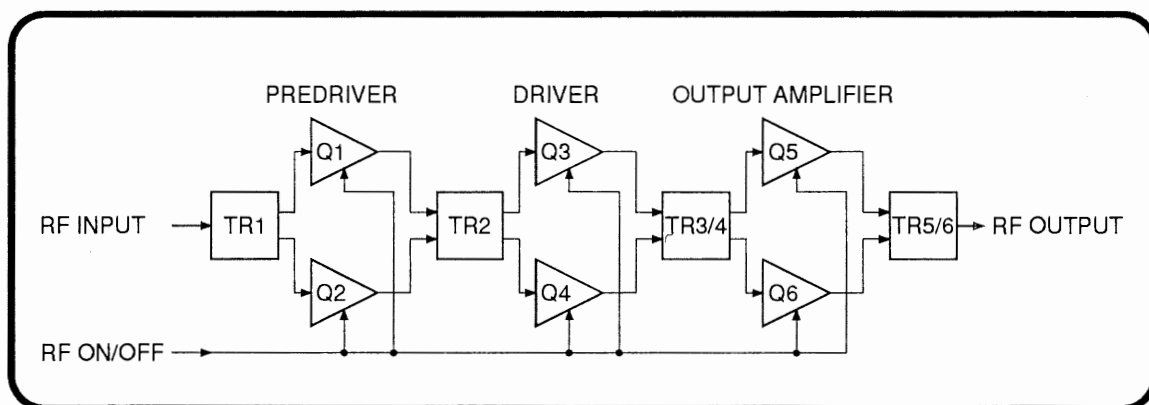

28370

CONTENTS

2	INSTALLATION	2-1
2.1	ELECTRICAL CONNECTION AND ASSEMBLING	2-1

2 INSTALLATION

2.1 ELECTRICAL CONNECTION AND ASSEMBLING

T2131

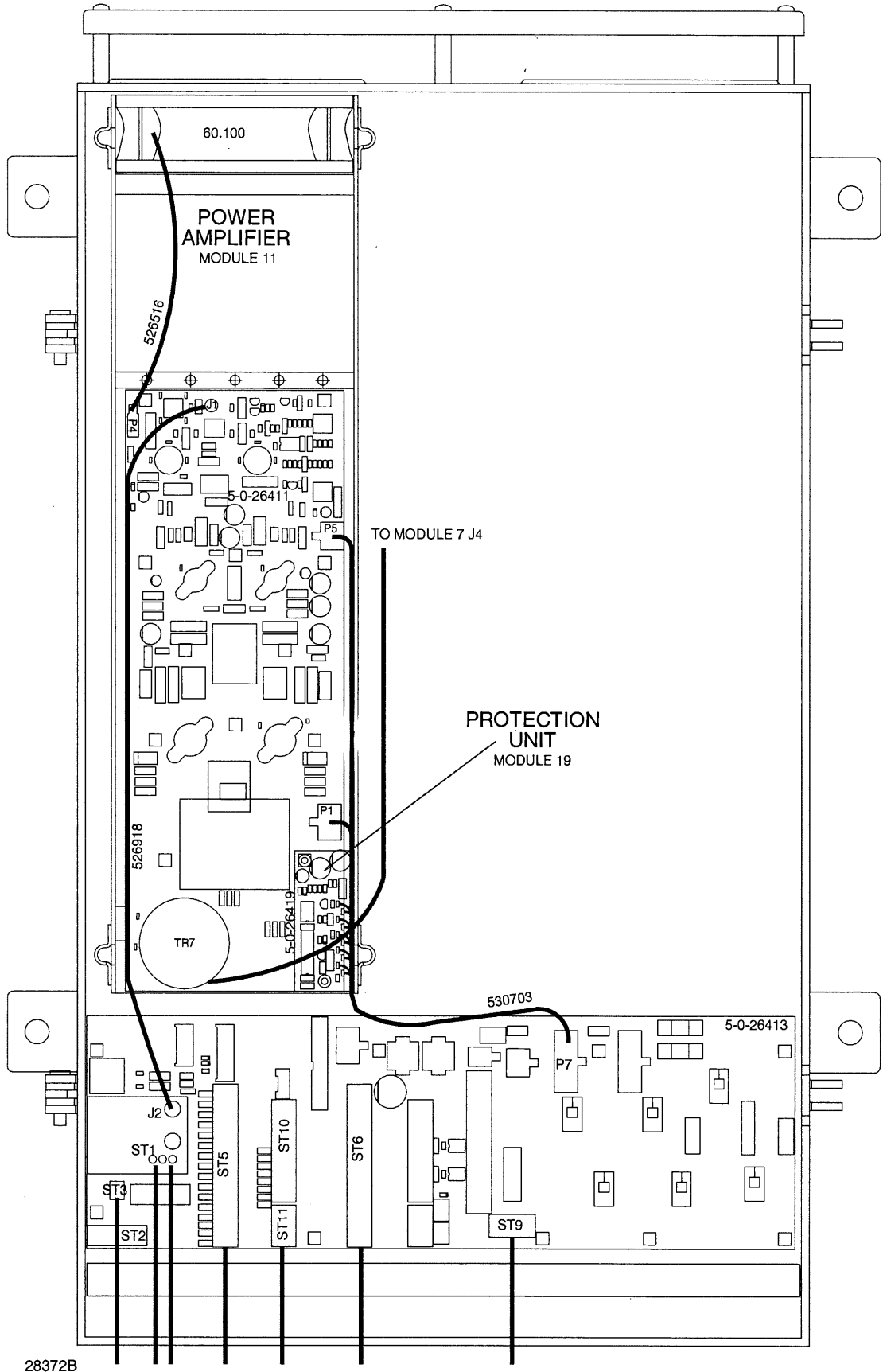

28372B

T2135

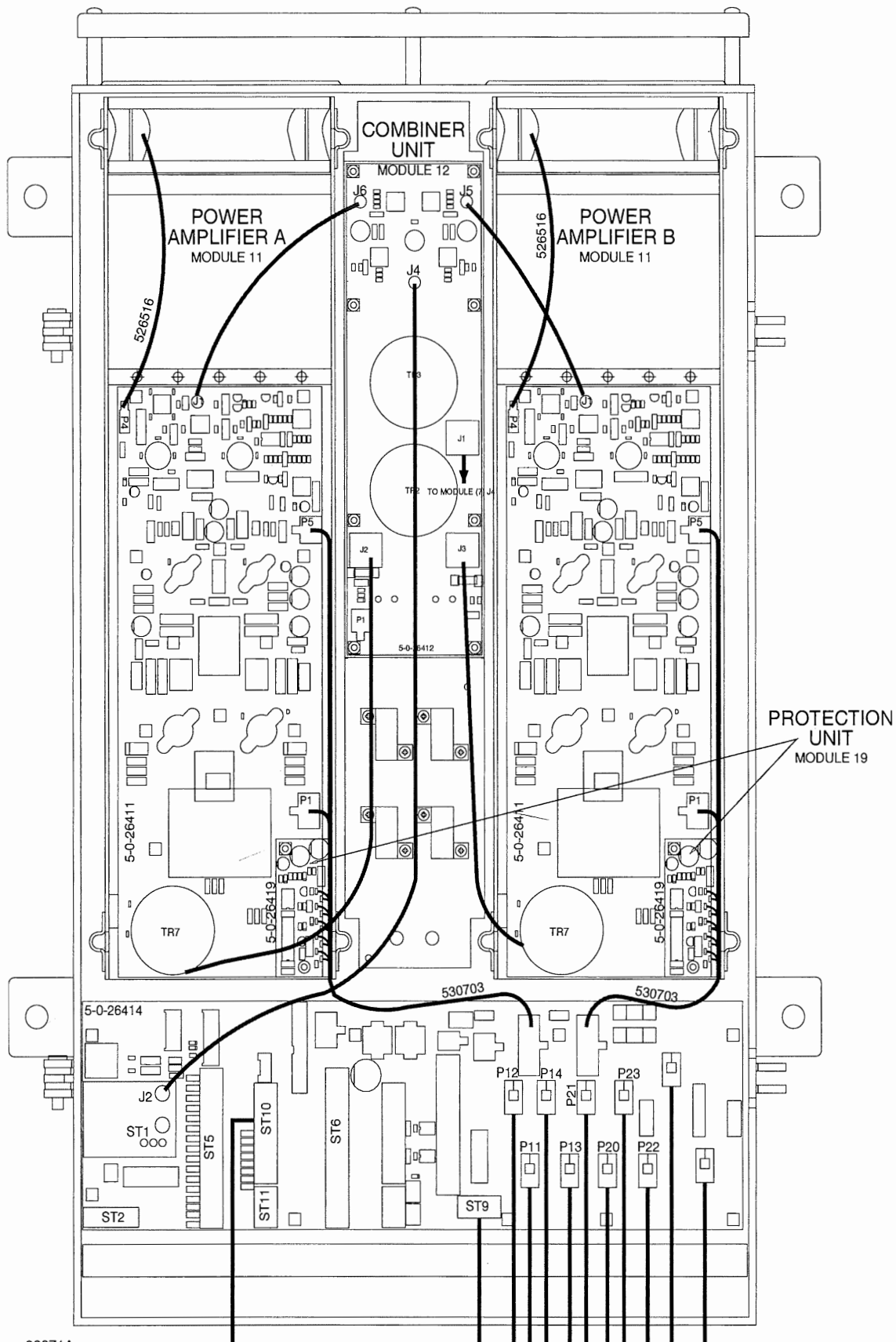

28371A

CONTENTS

3	SERVICE	
3.1	ALIGNMENT INSTRUCTIONS	3-1
3.2	PROPOSAL FOR NECESSARY MEASURING INSTRUMENTS	3-1
3.3	TROUBLE SHOOTING	3-1
3.3.1	CHECK OF THE BIAS CIRCUIT	3-1
3.3.2	CHECK OF BIAS CURRENT	3-1
3.3.2.1	DRIVER	3-1
3.3.2.2	OUTPUT AMPLIFIER	3-1
3.3.3	RF CHECK	3-2
3.4	ADJUSTMENT PROCEDURE	3-2
3.4.1	DRIVER BIAS	3-2
3.4.2	OUTPUT AMPLIFIER BIAS	3-2
3.5	NECESSARY ADJUSTMENTS AFTER REPAIR	3-2
3.6	PERFORMANCE CHECK	3-2

3 SERVICE

3.1 ALIGNMENT INSTRUCTIONS

INTRODUCTION

The measuring values indicated in chapter 5. CIRCUIT DESCRIPTION AND SCHEMATIC DIAGRAMS are typical values and as indicated it will be necessary to use instruments in absolute conformity with the below list:

3.2 PROPOSAL FOR NECESSARY MEASURING INSTRUMENTS

Tone Generator type PM5107	PHILIPS
Electronic Multimeter type PM2505	PHILIPS
RF Directional Wattmeter model 43	BIRD
Oscilloscope type PM321	PHILIPS
Dummy load 50 ohm/600W	
Power supply 21-32V,	50A (600W transmitter)
	100A (1200W transmitter)

3.3 TROUBLE SHOOTING

In this section you will find guidelines which will help you to find the fault component.

3.3.1 CHECK OF THE BIAS CIRCUIT

Unplug P1 on the power amplifier module.
Select SP-33-0 (see part I chapter 3 service programmes).
Check the voltage at:

- TP 1 = 12V +/- 0.5V
- TP 2 = 0.6V +/- 0.1V
- TP 3 = 0.6V +/- 0.1 V

If one of the above voltages, is far out of limit, the fault is in the bias circuit.

3.3.2 CHECK OF BIAS CURRENT

3.3.2.1 DRIVER

Connect an ammeter (1Amp) in series with P1 pin 1 and J1 pin 1. Select SP-33-0 (see part I chapter 3 service programmes). The meter reading must be 60mA +/- 20mA (Q3). Then connect the amp meter in series with P1 pin 2 and J1 pin 2. The meter reading must be 60mA +/-20mA (Q4).

3.3.2.2 OUTPUT AMPLIFIER

Connect an ammeter 10A in series with P1 pin 3 and J1 pin 3. Select SP-33-0 (see part I chapter 3 service programmes). The meter reading must be 200 mA +/- 50 mA.

3.3.3 RF CHECK

Connect a 50 ohm dummyload to the output terminal ST3 on the connection board, and select SP-29-0. Check that the voltage and curveform are in accordance with the shown curveforms on the diagram in chapter 5.1.

3.4 ADJUSTMENT PROCEDURE

3.4.1 DRIVER BIAS

Connect an ammeter (1Amp) in series with P1 pin 1 and J1 pin 1. Select SP-33-0 and adjust R37 to a meter reading of 60mA +/- 15mA. Then connect the amp meter in series with P1 pin 2 and J1 pin 2. The meter reading must be 60mA +/-20mA (Q4).

3.4.2 OUTPUT AMPLIFIER BIAS

Connect an ammeter 10A in series with P1 pin 3 and J1 pin 3. Select SP-33-0 and adjust R51 to a meter reading of 200 mA +/- 50 mA.

3.5 NECESSARY ADJUSTMENTS AFTER REPAIR

When replacing D4, R38, R37, R36,Q3 or Q4 perform the adjustments in accordance with chapter 3.4.1.

When replacing D5, R40, R51, R52, Q5 or Q6 perform the adjustments in accordance with chapter 3.4.2.

3.6 PERFORMANCE CHECK

Connect a 50 ohm dummyload to the output terminal ST3 on the connection board. Select SP-29-0 and check the amplitude and waveform in accordance with the pictures shown on the diagram in chapter 5.1. The measured must be within +/- 30% of the shown values. Select SP-33-0 and check the current as described in chapter 3.4.1 and 3.4.2.

CONTENTS

4	MECHANICAL DESCRIPTION	4-1
4.1	MECHANICAL ASSEMBLING / DISASSEMBLING AND UNITS LOCATION	4-1

4 MECHANICAL DESCRIPTION

4.1 MECHANICAL ASSEMBLING / DISASSEMBLING AND UNITS LOCATION

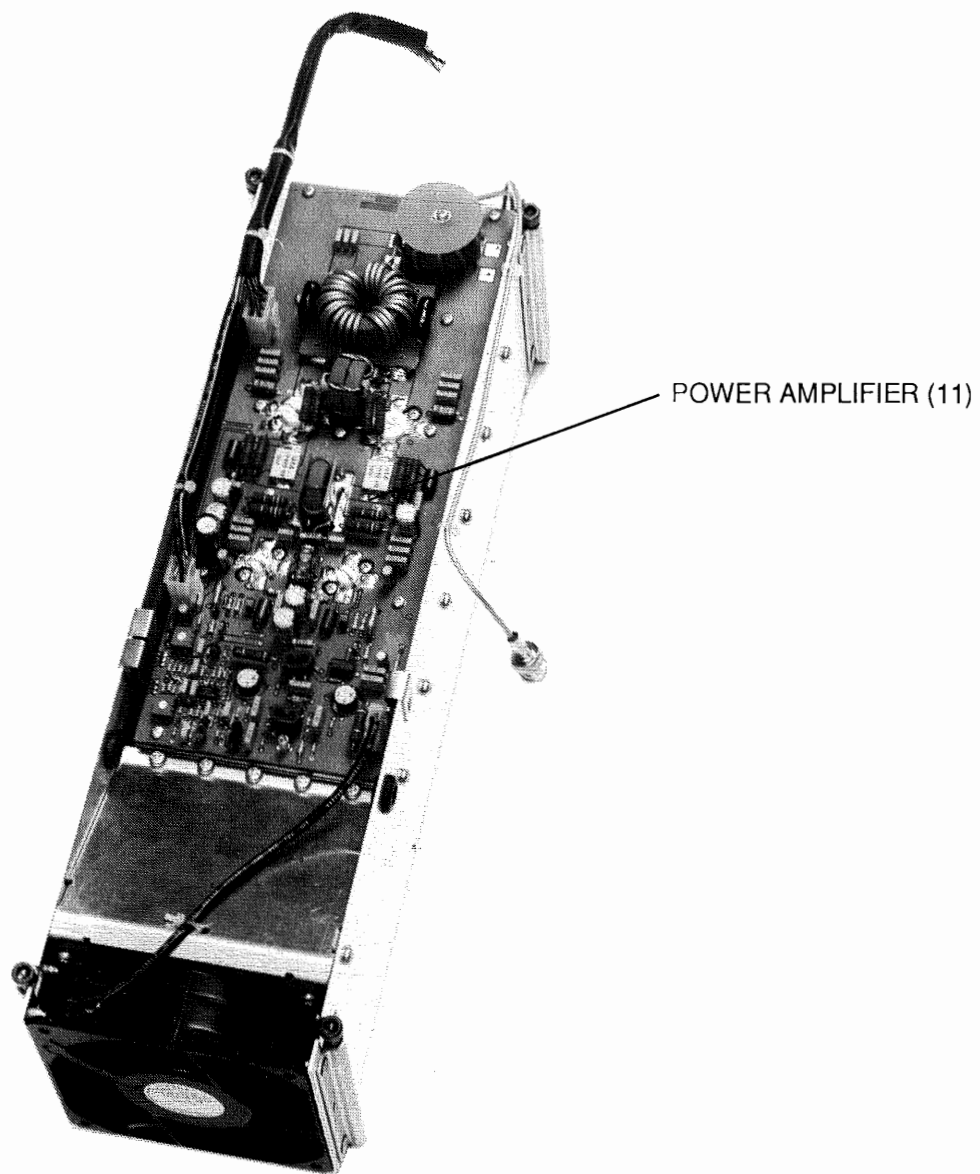

501142

CONTENTS

5	CIRCUIT DESCRIPTION AND SCHEMATIC DIAGRAMS	
5.1	POWER AMPLIFIER (MODULE 11) PART NO. 626411	5-1
5.2	PROTECTION (MODULE 19) PART NO. 626419	5-5

5 CIRCUIT DESCRIPTION AND SCHEMATIC DIAGRAMS

5.1 POWER AMPLIFIER (MODULE 11) PART NO. 626411

The power amplifier has a total gain of approx. 43 dB and the output power is 650W PEP.

The power amplifier has three stages: predriver, driver, output amplifier.

The predriver is a push-pull class A amplifier, consisting of Q1, Q2 and with a gain of 15 dB. Q8 and the voltage divider R33, R34 are bias supply for the predriver. Q9 can switch off the bias to the predriver.

The driver is a push-pull class B amplifier, consisting of Q3, Q4 (matched pairs) and the total gain is 17 dB.

The bias supply regulator consists of Q11 and U1,2. The diodes D2, D3 are mounted on the top of Q3, Q4 and are used for temperature stabilization of the bias current in Q3 and Q4.

R37 is used for adjusting the bias current in Q3 and Q4.

The output amplifier is a push-pull class B amplifier, consisting of Q5, Q6 (matched pairs) and the power gain is 11 dB.

The bias supply regulator consists of Q13 and U1,1.

The diode D4 is mounted on the top of Q5 and is used for temperature stabilization of the bias current in Q5, Q6. R51 is used for adjustment of the bias current in Q5, Q6.

Q8, Q10 and Q12 are used to switch off the bias. This is done in standby mode and under receive condition in telex mode.

COMPONENT LOCATION POWER AMPLIFIER MODULE 11

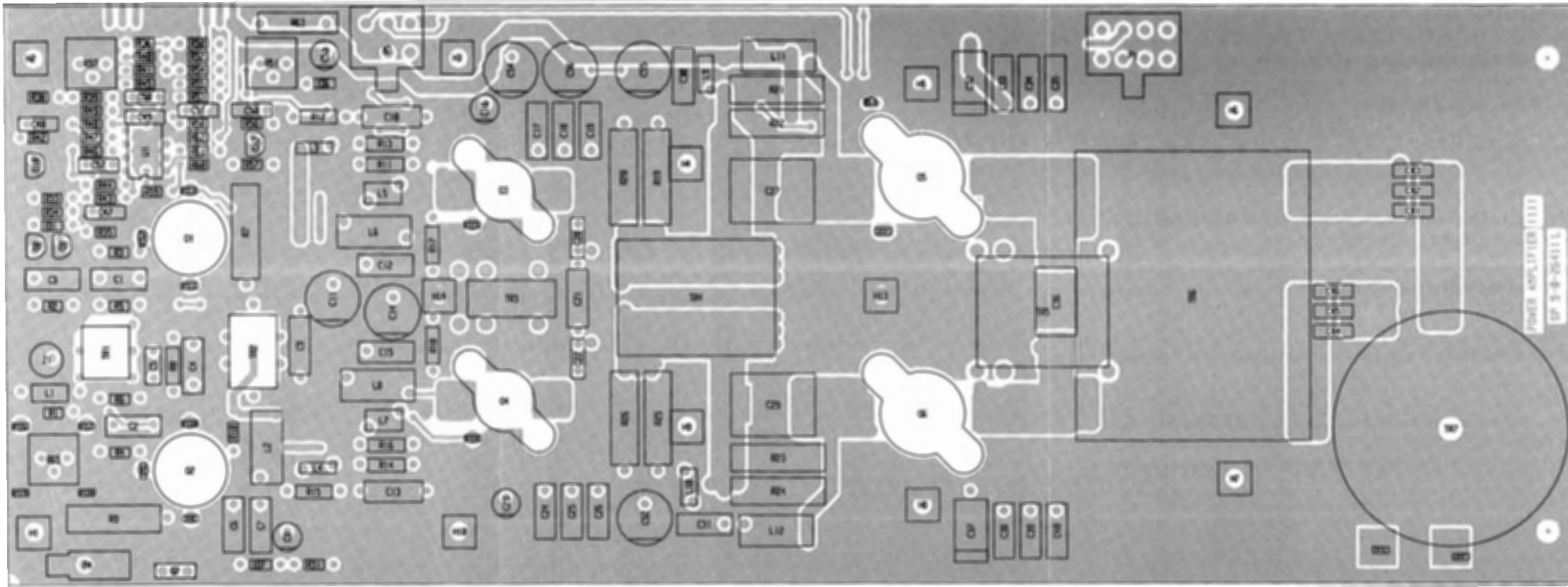

View from component side with upper side tracks.

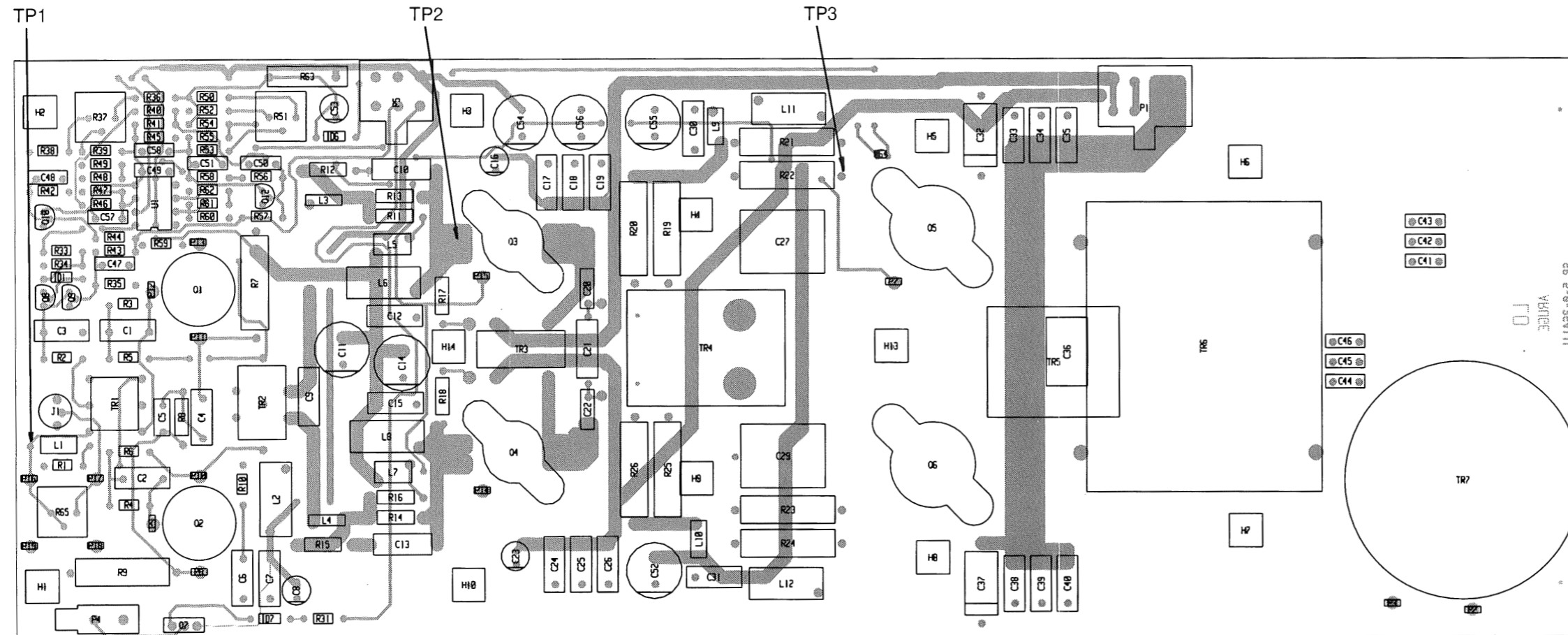

View from component side with lower side tracks.

PCB rev. 26411L

POWER AMPLIFIER MODULE 11

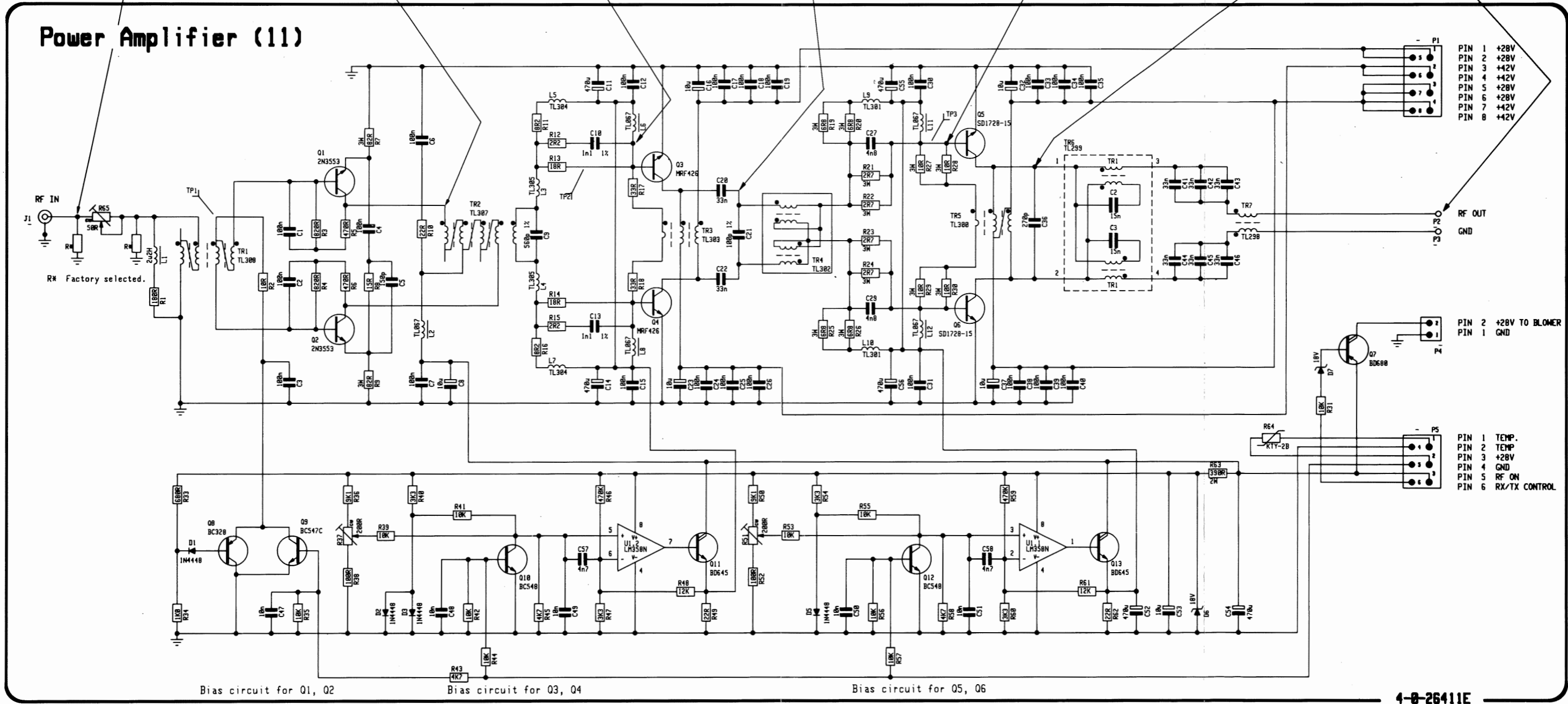
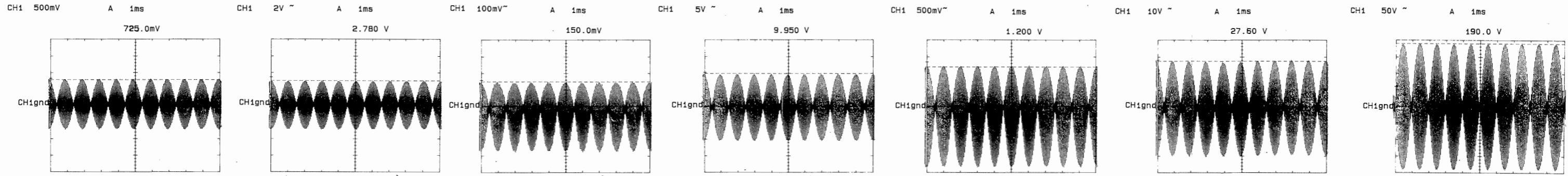

4-8-26411E

5.2 PROTECTION (MODULE 19) PART NO. 626419

This circuit protects the power output transistors from excessive current. This is done by sensing the 42V supply to the power transistors, when this voltage drops down to 38V the input power to the power amplifier are reduced by approx. 2dB. This reduction will remain until a key off/on occur.

COMPONENT LOCATION PROTECTION MODULE 19

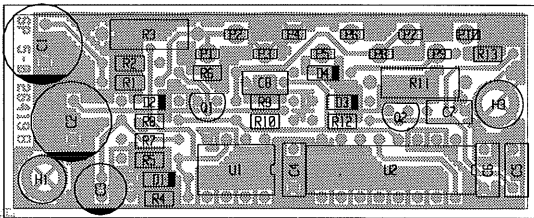

View from component side with upper side tracks.

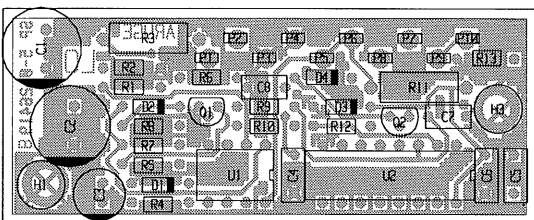

View from component side with lower side tracks.

PCB rev. 26419B

PROTECTION MODULE 19

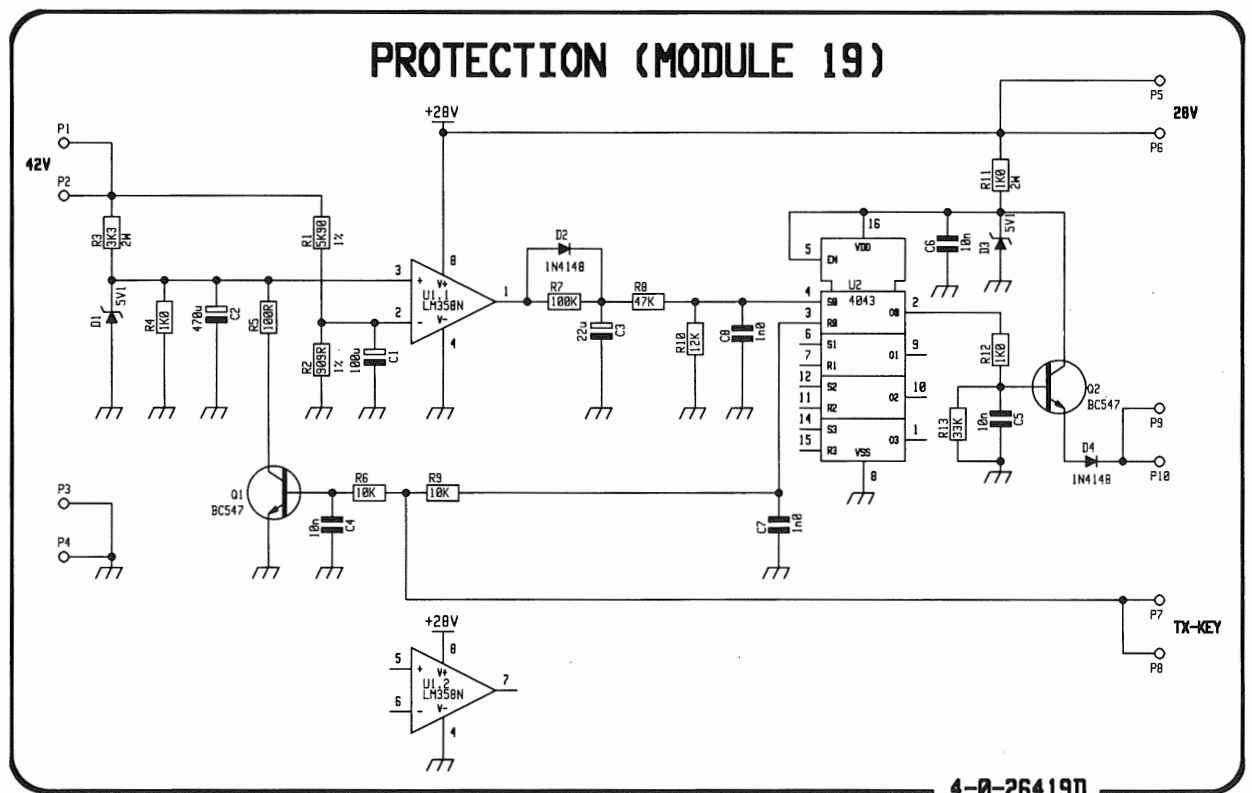

This diagram is valid for PCB rev. 26419B

CONTENTS

6

PARTS LISTS

6-1

GRØN SIDE

6 PARTS LISTS

PA UNIT 600/1200W		HF SSB PROGRAMME	ECI A/S	0-0-26393	726393
POSITION	DESCRIPTION		MANUFACTOR	TYPE	PART NO.
VARIOUS	BLOWER CABLE N2171/600W		ECI A/S	3-0-26516	526516
VARIOUS	FAN 24VDC	119x119x38mm	PAPST	4124 KX	60.100
-11	POWER AMPLIFIER MODULE 11	T2131	ECI A/S	5-0-26411L / 4-0-26411E	626411
VARIOUS	PROTECTION MODULE (19)	FOR 600W PA UNIT	ECI A/S	5-0-26419B / 4-0-26419D	626419
D2-11	DIODE HIGH SPEED	1N4448	PHILIPS	1N4448	25.147
D3-11	DIODE HIGH SPEED	1N4448	PHILIPS	1N4448	25.147
D5-11	DIODE HIGH SPEED	1N4448	PHILIPS	1N4448	25.147
Q1-11	TRANSISTOR RF MED.POWER	NPN TO-39 2N3553	PHILIPS	2N3553	29.315
Q2-11	TRANSISTOR RF MED.POWER	NPN TO-39 2N3553	PHILIPS	2N3553	29.315
Q3-11	TRANSISTOR RF POWER	MRF426 MATCHED PAIR (hFE)	MOTOROLA	MRF 426 hFE SORTED	29.266
Q4-11	TRANSISTOR RF POWER	MRF426 MATCHED PAIR (hFE)	MOTOROLA	1SET=2PCS MRF 426 hFE SORTED	29.266
Q5-11	TRANSISTOR RF POWER	TH430 MATCHED PAIR (hFE)	THOMSON	1SET=2PCS SD 1728-15 PAR	29.268
Q6-11	TRANSISTOR RF POWER	TH430 MATCHED PAIR (hFE)	THOMSON	1SET=2PCS GRP:C,D,E,F,G SD 1728-15 PAR	29.268
Q11-11	TRANSISTOR AF POWER NPN	DARLINGTON BD645/BDX53	SGS	1SET=2PCS GRP:C,D,E,F,G BDX53	29.122
Q13-11	TRANSISTOR AF POWER NPN	DARLINGTON BD645/BDX53	SGS	BDX53	29.122
R64-11	RESISTOR TEMP.SENSOR	2k0 2.5% AT 25 CENTIGRADE	SIEMENS	Q62705-K245, -K247 KTY11-5, KTY11-7	07.151

POWER AMPLIFIER MODULE 11		T2131	ECI A/S	5-0-26411L / 4-0-26411E	626411
POSITION	DESCRIPTION		MANUFACTOR	TYPE	PART NO.
C1-11	CAPACITOR MKT	100nF 10% 100VDC	ERO	MKT 1818-410/01 5-G	11.180
C2-11	CAPACITOR MKT	100nF 10% 100VDC	ERO	MKT 1818-410/01 5-G	11.180
C3-11	CAPACITOR MKT	100nF 10% 100VDC	ERO	MKT 1818-410/01 5-G	11.180
C4-11	CAPACITOR MKT	100nF 10% 100VDC	ERO	MKT 1818-410/01 5-G	11.180
C5-11	CAPACITOR CERAMIC	150pF 2% N150 100VDC	PHILIPS	2222 679 (687,689) 34151	15.148
C6-11	CAPACITOR MKT	100nF 10% 100VDC	ERO	MKT 1818-410/01 5-G	11.180
C7-11	CAPACITOR MKT	100nF 10% 100VDC	ERO	MKT 1818-410/01 5-G	11.180
C8-11	CAPACITOR ELECTROLYTIC	10uF 20% 35VDC	ELNA	RJ2-35-V-100-M-T34(T58)	14.512
C9-11	CAPACITOR POLYSTYRENE	560pF 1% 630VDC	PHILIPS	2222 431 85601	10.433
C10-11	CAPACITOR POLYSTYRENE	1n1F 1% 160VDC	PHILIPS	2222 429 81102	10.351
C11-11	CAPACITOR ELECTROLYTIC	470uF -20/+50% 10VDC	ELNA	RJ2-10-V-471-M-F	14.633
C12-11	CAPACITOR MKT	100nF 10% 100VDC	ERO	MKT 1818-410/01 5-G	11.180
C13-11	CAPACITOR POLYSTYRENE	1n1F 1% 160VDC	PHILIPS	2222 429 81102	10.351
C14-11	CAPACITOR ELECTROLYTIC	470uF -20/+50% 10VDC	ELNA	RJ2-10-V-471-M-F	14.633
C15-11	CAPACITOR MKT	100nF 10% 100VDC	ERO	MKT 1818-410/01 5-G	11.180
C16-11	CAPACITOR ELECTROLYTIC	10uF 20% 35VDC	ELNA	RJ2-35-V-100-M-T34(T58)	14.512
C17-11	CAPACITOR MKT	100nF 10% 100VDC	ERO	MKT 1818-410/01 5-G	11.180
C18-11	CAPACITOR MKT	100nF 10% 100VDC	ERO	MKT 1818-410/01 5-G	11.180
C19-11	CAPACITOR MKT	100nF 10% 100VDC	ERO	MKT 1818-410/01 5-G	11.180
C20-11	CAPACITOR MKT	33nF 5% 100VDC	PHILIPS	2222 370 89333	11.176
C21-11	CAPACITOR POLYSTYRENE	100pF 1% 630VDC	PHILIPS	2222 431 81001	10.400
C22-11	CAPACITOR MKT	33nF 5% 100VDC	PHILIPS	2222 370 89333	11.176
C23-11	CAPACITOR ELECTROLYTIC	10uF 20% 35VDC	ELNA	RJ2-35-V-100-M-T34(T58)	14.512
C24-11	CAPACITOR MKT	100nF 10% 100VDC	ERO	MKT 1818-410/01 5-G	11.180
C25-11	CAPACITOR MKT	100nF 10% 100VDC	ERO	MKT 1818-410/01 5-G	11.180
C26-11	CAPACITOR MKT	100nF 10% 100VDC	ERO	MKT 1818-410/01 5-G	11.180
C27-11	CAPACITOR CERAMIC	4800 pF 10% 100V RF	#UNILATOR	102/4801K/MG0	18.155
C29-11	CAPACITOR CERAMIC	4800 pF 10% 100V RF	#UNILATOR	102/4801K/MG0	18.155
C30-11	CAPACITOR MKT	100nF 10% 100VDC	ERO	MKT 1818-410/01 5-G	11.180
C31-11	CAPACITOR MKT	100nF 10% 100VDC	ERO	MKT 1818-410/01 5-G	11.180
C32-11	CAPACITOR ELECTROLYTIC	10uF -10/+50% 63VDC	PHILIPS	2222 030 38109	14.546
C33-11	CAPACITOR MKT	100nF 10% 100VDC	ERO	MKT 1818-410/01 5-G	11.180
C34-11	CAPACITOR MKT	100nF 10% 100VDC	ERO	MKT 1818-410/01 5-G	11.180
C35-11	CAPACITOR MKT	100nF 10% 100VDC	ERO	MKT 1818-410/01 5-G	11.180
C36-11	CAPACITOR CERAMIC	270 pF 10% 25KV	#UNILATOR	TYPE 101-STRIP LEAD	18.150
C37-11	CAPACITOR ELECTROLYTIC	10uF -10/+50% 63VDC	PHILIPS	2222 030 38109	14.546
C38-11	CAPACITOR MKT	100nF 10% 100VDC	ERO	MKT 1818-410/01 5-G	11.180
C39-11	CAPACITOR MKT	100nF 10% 100VDC	ERO	MKT 1818-410/01 5-G	11.180

POSITION	DESCRIPTION		MANUFACTURER	TYPE	PART NO.
C40-11	CAPACITOR MKT	100nF 10% 100VDC	ERO	MKT 1818-410/01 5-G	11.180
C41-11	CAPACITOR MKT	33nF 5% 100VDC	PHILIPS	2222 370 89333	11.176
C42-11	CAPACITOR MKT	33nF 5% 100VDC	PHILIPS	2222 370 89333	11.176
C43-11	CAPACITOR MKT	33nF 5% 100VDC	PHILIPS	2222 370 89333	11.176
C44-11	CAPACITOR MKT	33nF 5% 100VDC	PHILIPS	2222 370 89333	11.176
C45-11	CAPACITOR MKT	33nF 5% 100VDC	PHILIPS	2222 370 89333	11.176
C46-11	CAPACITOR MKT	33nF 5% 100VDC	PHILIPS	2222 370 89333	11.176
C47-11	CAPACITOR MKT	10nF 20% 100VDC	PHILIPS	2222 370 38103	11.168
C48-11	CAPACITOR MKT	10nF 20% 100VDC	PHILIPS	2222 370 38103	11.168
C49-11	CAPACITOR MKT	10nF 20% 100VDC	PHILIPS	2222 370 38103	11.168
C50-11	CAPACITOR MKT	10nF 20% 100VDC	PHILIPS	2222 370 38103	11.168
C51-11	CAPACITOR MKT	10nF 20% 100VDC	PHILIPS	2222 370 38103	11.168
C52-11	CAPACITOR ELECTROLYTIC	470uF -20/+50% 10VDC	ELNA	RJ2-10-V-471-M-F	14.633
C53-11	CAPACITOR ELECTROLYTIC	10uF 20% 35VDC	ELNA	RJ2-35-V-100-M-T34(T58)	14.512
C54-11	CAPACITOR ELECTROLYTIC	470uF -20/+50% 40VDC	ERO	EKM 05 FG 347 G 05	14.650
C55-11	CAPACITOR ELECTROLYTIC	470uF -20/+50% 10VDC	ELNA	RJ2-10-V-471-M-F	14.633
C56-11	CAPACITOR ELECTROLYTIC	470uF -20/+50% 10VDC	ELNA	RJ2-10-V-471-M-F	14.633
C57-11	CAPACITOR MKT	4n7F 10% 63VDC	PHILIPS	2222 370 88472	11.374
C58-11	CAPACITOR MKT	4n7F 10% 63VDC	PHILIPS	2222 370 88472	11.374
D1-11	DIODE HIGH SPEED	1N4448	PHILIPS	1N4448	25.147
D2-11	DIODE HIGH SPEED	1N4448	PHILIPS	1N4448	25.147
D3-11	DIODE HIGH SPEED	1N4448	PHILIPS	1N4448	25.147
D5-11	DIODE HIGH SPEED	1N4448	PHILIPS	1N4448	25.147
D6-11	DIODE ZENER	18V 5% 0.4W BZX79C18	PHILIPS	BZX79C18	26.564
D7-11	DIODE ZENER	18V 5% 0.4W BZX79C18	PHILIPS	BZX79C18	26.564
J1-11	SOCKET COAX FOR PCB	VERTICAL	TAIKO	TMP-J01X-V6	78.518
L1-11	CHOKE FIXED	2u2H 10%	SIEMENS	B78108-T1222-K	20.351
L2-11	COIL	TL067	ECI A/S	6-0-20854A 400067=20.053	400067
L3-11	COIL	TL305	ECI A/S	6-0-23127	400305
L4-11	COIL	TL305	ECI A/S	6-0-23127	400305
L5-11	COIL	TL304	ECI A/S	6-0-23126	400304
L6-11	COIL	TL067	ECI A/S	6-0-20854A 400067=20.053	400067
L7-11	COIL	TL304	ECI A/S	6-0-23126	400304
L8-11	COIL	TL067	ECI A/S	6-0-20854A 400067=20.053	400067
L9-11	COIL	TL301	ECI A/S	6-0-23123	400301
L10-11	COIL	TL301	ECI A/S	6-0-23123	400301
L11-11	COIL	TL067	ECI A/S	6-0-20854A 400067=20.053	400067
L12-11	COIL	TL067	ECI A/S	6-0-20854A 400067=20.053	400067
P1-11	MULTIPLUG	2x4 POLES PCB VERSION	MOLEX	39-28-1083	78.218
P2-11	SOLDER LUG	PCB VERSION	VOGT AG	01015/Bz-Sn	82.005
P3-11	SOLDER LUG	PCB VERSION	VOGT AG	01015/Bz-Sn	82.005
P4-11	PLUG 2POLES		MOLEX	39-28-1023	78.215
P5-11	MULTIPLUG	2x3 POLES PCB VERSION	MOLEX	39-28-1063	78.217
P6-11	SOLDER LUG	PCB VERSION	VOGT AG	01015/Bz-Sn	82.005
P7-11	SOLDER LUG	PCB VERSION	VOGT AG	01015/Bz-Sn	82.005
P8-11	SOLDER LUG	PCB VERSION	VOGT AG	01015/Bz-Sn	82.005
P9-11	SOLDER LUG	PCB VERSION	VOGT AG	01015/Bz-Sn	82.005
P10-11	SOLDER LUG	PCB VERSION	VOGT AG	01015/Bz-Sn	82.005
P11-11	SOLDER LUG	PCB VERSION	VOGT AG	01015/Bz-Sn	82.005
P12-11	SOLDER LUG	PCB VERSION	VOGT AG	01015/Bz-Sn	82.005
Q1-11	TRANSISTOR RF MED.POWER	NPN TO-39 2N3553	PHILIPS	2N3553	29.315
Q2-11	TRANSISTOR RF MED.POWER	NPN TO-39 2N3553	PHILIPS	2N3553	29.315
Q3-11	TRANSISTOR RF POWER	MRF426 MATCHED PAIR (hFE)	MOTOROLA	MRF 426 hFE SORTED 1SET=2PCS	29.266
Q4-11	TRANSISTOR RF POWER	MRF426 MATCHED PAIR (hFE)	MOTOROLA	MRF 426 hFE SORTED 1SET=2PCS	29.266
Q5-11	TRANSISTOR RF POWER	TH430 MATCHED PAIR (hFE)	THOMSON	SD 1728-15 PAR 1SET=2PCS GRP:C,D,E,F,G	29.268
Q6-11	TRANSISTOR RF POWER	TH430 MATCHED PAIR (hFE)	THOMSON	SD 1728-15 PAR 1SET=2PCS GRP:C,D,E,F,G	29.268
Q7-11	TRANSISTOR	BD680	PHILIPS*	BDX47	29.338
Q8-11	TRANSISTOR AF	PNP TO-92 BC328	MOTOROLA	BC328	28.050
Q9-11	TRANSISTOR AF	NPN BC547C TO-92	PHILIPS	BC547C	28.068
Q10-11	TRANSISTOR AF	BC548 NPN TO-92	PHILIPS	BC548 (-A/-B/-C)	28.070
Q11-11	TRANSISTOR AF POWER NPN	DARLINGTON BD645/BDX53	SGS	BDX53	29.122
Q12-11	TRANSISTOR AF	BC548 NPN TO-92	PHILIPS	BC548 (-A/-B/-C)	28.070

POSITION	DESCRIPTION	MANUFACTURER	TYPE	PART NO.	
Q13-11	TRANSISTOR AF POWER NPN	DARLINGTON	BD645/BDX53	SGS BDX53	29.122
R1-11	RESISTOR MF	180 OHM 5% 0.33W	PHILIPS	2322 187 73181	02.454
R2-11	RESISTOR MF	10 OHM 5% 0.33W	PHILIPS	2322 187 73109	02.424
R3-11	RESISTOR MF	820 OHM 5% 0.33W	PHILIPS	2322 187 73821	02.470
R4-11	RESISTOR MF	820 OHM 5% 0.33W	PHILIPS	2322 187 73821	02.470
R5-11	RESISTOR MF	470 OHM 5% 0.33W	PHILIPS	2322 187 73471	02.464
R6-11	RESISTOR MF	470 OHM 5% 0.33W	PHILIPS	2322 187 73471	02.464
R7-11	RESISTOR PMF	82 OHM 5% 3W	PHILIPS	2322 195 13829	04.672
R8-11	RESISTOR MF	15 OHM 5% 0.4W	PHILIPS	2322 181 53159	01.154
R9-11	RESISTOR PMF	82 OHM 5% 3W	PHILIPS	2322 195 13829	04.672
R10-11	RESISTOR MF	22 OHM 5% 0.33W	PHILIPS	2322 187 73229	02.432
R11-11	RESISTOR MF	8R2 OHM 5% 0.4W	PHILIPS	2322 181 53828	01.147
R12-11	RESISTOR MF	2R2 OHM 5% 0.4W	PHILIPS	2322 181 53228	01.133
R13-11	RESISTOR MF	18 OHM 5% 0.4W	PHILIPS	2322 181 53189	01.156
R14-11	RESISTOR MF	18 OHM 5% 0.4W	PHILIPS	2322 181 53189	01.156
R15-11	RESISTOR MF	2R2 OHM 5% 0.4W	PHILIPS	2322 181 53228	01.133
R16-11	RESISTOR MF	8R2 OHM 5% 0.4W	PHILIPS	2322 181 53828	01.147
R17-11	RESISTOR MF	33 OHM 5% 0.4W	PHILIPS	2322 181 53339	01.162
R18-11	RESISTOR MF	33 OHM 5% 0.4W	PHILIPS	2322 181 53339	01.162
R19-11	RESISTOR PMF	6R8 OHM 5% 3W	PHILIPS	2322 195 13688	04.648
R20-11	RESISTOR PMF	6R8 OHM 5% 3W	PHILIPS	2322 195 13688	04.648
R21-11	RESISTOR PMF	2R7 OHM 5% 3W	PHILIPS	2322 195 13278	04.634
R22-11	RESISTOR PMF	2R7 OHM 5% 3W	PHILIPS	2322 195 13278	04.634
R23-11	RESISTOR PMF	2R7 OHM 5% 3W	PHILIPS	2322 195 13278	04.634
R24-11	RESISTOR PMF	2R7 OHM 5% 3W	PHILIPS	2322 195 13278	04.634
R25-11	RESISTOR PMF	6R8 OHM 5% 3W	PHILIPS	2322 195 13688	04.648
R26-11	RESISTOR PMF	6R8 OHM 5% 3W	PHILIPS	2322 195 13688	04.648
R27-11	RESISTOR PMF	10 OHM 5% 3W	PHILIPS	2322 192 31009	04.650
R28-11	RESISTOR PMF	10 OHM 5% 3W	PHILIPS	2322 192 31009	04.650
R29-11	RESISTOR PMF	10 OHM 5% 3W	PHILIPS	2322 192 31009	04.650
R30-11	RESISTOR PMF	10 OHM 5% 3W	PHILIPS	2322 192 31009	04.650
R31-11	RESISTOR MF	10k OHM 5% 0.33W	PHILIPS	2322 187 73103	02.496
R33-11	RESISTOR MF	680 OHM 5% 0.33W	PHILIPS	2322 187 73681	02.468
R34-11	RESISTOR MF	1k0 OHM 5% 0.33W	PHILIPS	2322 187 73102	02.472
R35-11	RESISTOR MF	10k OHM 5% 0.33W	PHILIPS	2322 187 73103	02.496
R36-11	RESISTOR MF	9k1 OHM 5% 0.33W	PHILIPS	2322 187 73912	02.495
R37-11	PRESET CERMET	200 OHM 10% 0.5W	BOURNS	3386P-1-201	07.884
R38-11	RESISTOR MF	100 OHM 5% 0.33W	PHILIPS	2322 187 73101	02.448
R39-11	RESISTOR MF	10k OHM 5% 0.33W	PHILIPS	2322 187 73103	02.496
R40-11	RESISTOR MF	3k3 OHM 5% 0.33W	PHILIPS	2322 187 73332	02.484
R41-11	RESISTOR MF	10k OHM 5% 0.33W	PHILIPS	2322 187 73103	02.496
R42-11	RESISTOR MF	10k OHM 5% 0.33W	PHILIPS	2322 187 73103	02.496
R43-11	RESISTOR MF	4k7 OHM 5% 0.33W	PHILIPS	2322 187 73472	02.488
R44-11	RESISTOR MF	10k OHM 5% 0.33W	PHILIPS	2322 187 73103	02.496
R45-11	RESISTOR MF	4k7 OHM 5% 0.33W	PHILIPS	2322 187 73472	02.488
R46-11	RESISTOR MF	470k OHM 5% 0.33W	PHILIPS	2322 187 73474	02.536
R47-11	RESISTOR MF	3k3 OHM 5% 0.33W	PHILIPS	2322 187 73332	02.484
R48-11	RESISTOR MF	12k OHM 5% 0.33W	PHILIPS	2322 187 73123	02.498
R49-11	RESISTOR MF	22 OHM 5% 0.33W	PHILIPS	2322 187 73229	02.432
R50-11	RESISTOR MF	9k1 OHM 5% 0.33W	PHILIPS	2322 187 73912	02.495
R51-11	PRESET CERMET	200 OHM 10% 0.5W	BOURNS	3386P-1-201	07.884
R52-11	RESISTOR MF	100 OHM 5% 0.33W	PHILIPS	2322 187 73101	02.448
R53-11	RESISTOR MF	10k OHM 5% 0.33W	PHILIPS	2322 187 73103	02.496
R54-11	RESISTOR MF	3k3 OHM 5% 0.33W	PHILIPS	2322 187 73332	02.484
R55-11	RESISTOR MF	10k OHM 5% 0.33W	PHILIPS	2322 187 73103	02.496
R56-11	RESISTOR MF	10k OHM 5% 0.33W	PHILIPS	2322 187 73103	02.496
R57-11	RESISTOR MF	10k OHM 5% 0.33W	PHILIPS	2322 187 73103	02.496
R58-11	RESISTOR MF	4k7 OHM 5% 0.33W	PHILIPS	2322 187 73472	02.488
R59-11	RESISTOR MF	470k OHM 5% 0.33W	PHILIPS	2322 187 73474	02.536
R60-11	RESISTOR MF	3k3 OHM 5% 0.33W	PHILIPS	2322 187 73332	02.484
R61-11	RESISTOR MF	12k OHM 5% 0.33W	PHILIPS	2322 187 73123	02.498
R62-11	RESISTOR MF	22 OHM 5% 0.33W	PHILIPS	2322 187 73229	02.432
R63-11	RESISTOR PMF	390 OHM 5% 2W	PHILIPS	2322 194 13391	04.189
R64-11	RESISTOR TEMP.SENSOR	2k0 2.5% AT 25 CENTIGRADE	SIEMENS	Q62705-K245, -K247 KTY11-5, KTY11-7	07.151
R65-11	PRESET CERMET	50 OHM 10% 0.5W	* BOURNS	3386P-1-500	07.882
TR1-11	COIL	TL308	ECI A/S	6-0-23130	400308
TR2-11	COIL	TL307	ECI A/S	6-0-23129	400307
TR3-11	COIL	TL303	ECI A/S	6-0-23125	400303
TR4-11	COIL	TL302	ECI A/S	6-0-23124	400302
TR5-11	TRANSFORMER	TL300	ECI A/S	6-0-23122B	400300

POSITION	DESCRIPTION		MANUFACTURER	TYPE	PART NO.
TR6-11	OUTPUT TRANSFORMER	TL572	ECI A/S	6-0-27047	400572
TR7-11	BALUN FOR T2131	TL573	ECI A/S	6-0-27049A	400573
U1-11	DUAL OP AMP	LM358N	TEXAS	LM358P	31.100

OUTPUT TRANSFORMER	TL572	ECI A/S	6-0-27047	400572
--------------------	-------	---------	-----------	--------

POSITION	DESCRIPTION		MANUFACTURER	TYPE	PART NO.
C2	CAPACITOR MICA	15nF 10% 100VDC	N-T-D	SDM20 C 153 K 1	18.145
C3	CAPACITOR MICA	15nF 10% 100VDC	N-T-D	SDM20 C 153 K 1	18.145
TR1	COAX CABLES FOR TL299		ECI A/S	500299 CABLES FOR TL299	500299
TR1	TOROIDE		*PHILIPS	4322 020 97200	35.027

PROTECTION MODULE (19)	FOR 600W PA UNIT	ECI A/S	5-0-26419B / 4-0-26419D	626419
------------------------	------------------	---------	-------------------------	--------

POSITION	DESCRIPTION		MANUFACTURER	TYPE	PART NO.
C1-19	CAPACITOR ELECTROLYTIC	100uF -10/+50% 25VDC	ERO	EKM 00 CC 310 E G5	14.610
C2-19	CAPACITOR ELECTROLYTIC	470uF -20/+50% 10VDC	ELNA	RJ2-10-V-471-M-F	14.633
C3-19	CAPACITOR ELECTROLYTIC	22uF 20% 35VDC	ELNA	RJ2-35-V-220-M-F1	14.516
C4-19	CAPACITOR CERAMIC	10nF -20/+80% CL2 50VDC	KCK	RT-HE70 SK YF 103 Z	15.170
C5-19	CAPACITOR CERAMIC	10nF -20/+80% CL2 50VDC	KCK	RT-HE70 SK YF 103 Z	15.170
C6-19	CAPACITOR CERAMIC	10nF -20/+80% CL2 50VDC	KCK	RT-HE70 SK YF 103 Z	15.170
C7-19	CAPACITOR CERAMIC	1nF 10% 50VDC CL2	KCK	RT-SK-HE50 SJYB 102 K	16.160
C8-19	CAPACITOR CERAMIC	1nF 10% 50VDC CL2	KCK	RT-SK-HE50 SJYB 102 K	16.160
D1-19	DIODE ZENER	5.1V 2% 0.4W BZX79B5V1	PHILIPS	BZX79B5V1	26.497
D2-19	DIODE	1N4148 HIGH SPEED	PHILIPS	1N4148-143	25.131
D3-19	DIODE ZENER	5.1V 2% 0.4W BZX79B5V1	PHILIPS	BZX79B5V1	26.497
D4-19	DIODE	1N4148 HIGH SPEED	PHILIPS	1N4148-143	25.131
P1-19	SOLDER LUG	PCB VERSION	VOGT AG	01015/Bz-Sn	82.005
P2-19	SOLDER LUG	PCB VERSION	VOGT AG	01015/Bz-Sn	82.005
P3-19	SOLDER LUG	PCB VERSION	VOGT AG	01015/Bz-Sn	82.005
P4-19	SOLDER LUG	PCB VERSION	VOGT AG	01015/Bz-Sn	82.005
P5-19	SOLDER LUG	PCB VERSION	VOGT AG	01015/Bz-Sn	82.005
P6-19	SOLDER LUG	PCB VERSION	VOGT AG	01015/Bz-Sn	82.005
P7-19	SOLDER LUG	PCB VERSION	VOGT AG	01015/Bz-Sn	82.005
P8-19	SOLDER LUG	PCB VERSION	VOGT AG	01015/Bz-Sn	82.005
P9-19	SOLDER LUG	PCB VERSION	VOGT AG	01015/Bz-Sn	82.005
P10-19	SOLDER LUG	PCB VERSION	VOGT AG	01015/Bz-Sn	82.005
Q1-19	TRANSISTOR	BC547	PHILIPS*	BC547	28.062
Q2-19	TRANSISTOR	BC547	PHILIPS*	BC547	28.062
R1-19	RESISTOR MF	5k90 OHM 1% 0.25W	PHILIPS	2322 157 15902	02.220
R2-19	RESISTOR MF	909 OHM 1% 0.25W	PHILIPS	2322 157 19091	02.218
R3-19	RESISTOR PMF	3k3 OHM 5% 2W	PHILIPS	2322 194 13332	04.209
R4-19	RESISTOR MF	1k0 OHM 5% 0.33W	PHILIPS	2322 187 73102	02.472
R5-19	RESISTOR MF	100 OHM 5% 0.33W	PHILIPS	2322 187 73101	02.448
R6-19	RESISTOR MF	10k OHM 5% 0.33W	PHILIPS	2322 187 73103	02.496
R7-19	RESISTOR MF	100k OHM 5% 0.33W	PHILIPS	2322 187 73104	02.520
R8-19	RESISTOR MF	47k OHM 5% 0.33W	PHILIPS	2322 187 73473	02.512
R9-19	RESISTOR MF	10k OHM 5% 0.33W	PHILIPS	2322 187 73103	02.496
R10-19	RESISTOR MF	12k OHM 5% 0.33W	PHILIPS	2322 187 73123	02.498
R11-19	RESISTOR PMF	1k0 OHM 5% 2W	PHILIPS	2322 194 13102	04.200
R12-19	RESISTOR MF	1k0 OHM 5% 0.33W	PHILIPS	2322 187 73102	02.472
R13-19	RESISTOR MF	33k OHM 5% 0.33W	PHILIPS	2322 187 73333	02.508
U1-19	DUAL OP AMP	LM358N	TEXAS	LM358P	31.100
U2-19	QUAD R-S LATCH	MC14043BCP	*SIGNETICS	HEF 4043 BP	33.160

TECHNICAL MANUAL FOR COMBINER UNIT
(Only in 1200W, T2135) PART NO. 726394

CONTENTS

1	GENERAL INFORMATION	
1.1	INTRODUCTION	1-1
1.2	PRINCIPLE OF OPERATION	1-1
2	INSTALLATION	
2.1	ELECTRICAL CONNECTION AND ASSEMBLING	2-1
3	SERVICE	
3.1	ALIGNMENT INSTRUCTIONS	3-1
3.2	PROPOSAL FOR NECESSARY MEASURING INSTRUMENTS	3-1
3.3	TROUBLE SHOOTING	3-1
3.4	ADJUSTMENT PROCEDURE	3-2
3.5	NECESSARY ADJUSTMENTS AFTER REPAIR	3-2
3.6	PERFORMANCE CHECK	3-2
4	MECHANICAL DESCRIPTION	
4.1	MECHANICAL ASSEMBLING / DISASSEMBLING AND UNITS LOCATION	4-1
5	CIRCUIT DESCRIPTION AND SCHEMATIC DIAGRAMS	
5.1	COMBINER (MODULE 12) PART NO. 626412	5-1
6	PARTS LISTS	

CONTENTS

1	GENERAL INFORMATION	1-1
1.1	INTRODUCTION	1-1
1.2	PRINCIPLE OF OPERATION	1-1

1 GENERAL INFORMATION

1.1 INTRODUCTION

This section gives you all necessary information to make service of this unit down to component level.

1.2 PRINCIPLE OF OPERATION

The combiner unit contains the power splitter and the power combiner.

The RF signal from RE2100 is fed through the splitter to two buffer amplifiers, one for each PA unit (A and B). The gain from input to output is 0 dB.

The signal from the two power amplifiers (A and B) is combined in the combiner and then through the 4:9 impedance transformer to a 50 ohm output impedance.

For each PA unit there is a power detector. The detector output is fed to the TX processor.

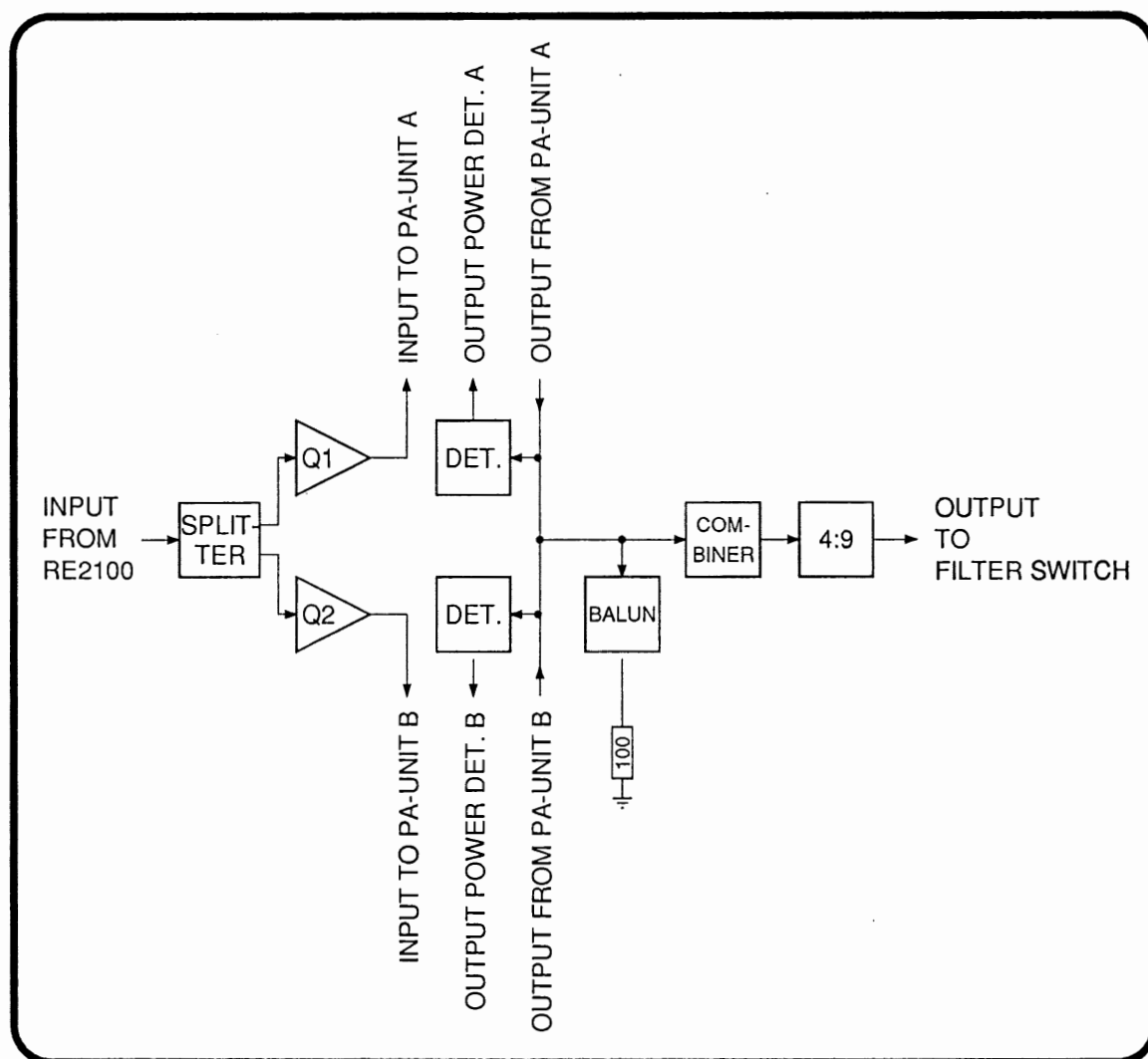

28373A

CONTENTS

2	INSTALLATION	2-1
2.1	ELECTRICAL CONNECTION AND ASSEMBLING	2-1

2 INSTALLATION

2.1 ELECTRICAL CONNECTION AND ASSEMBLING

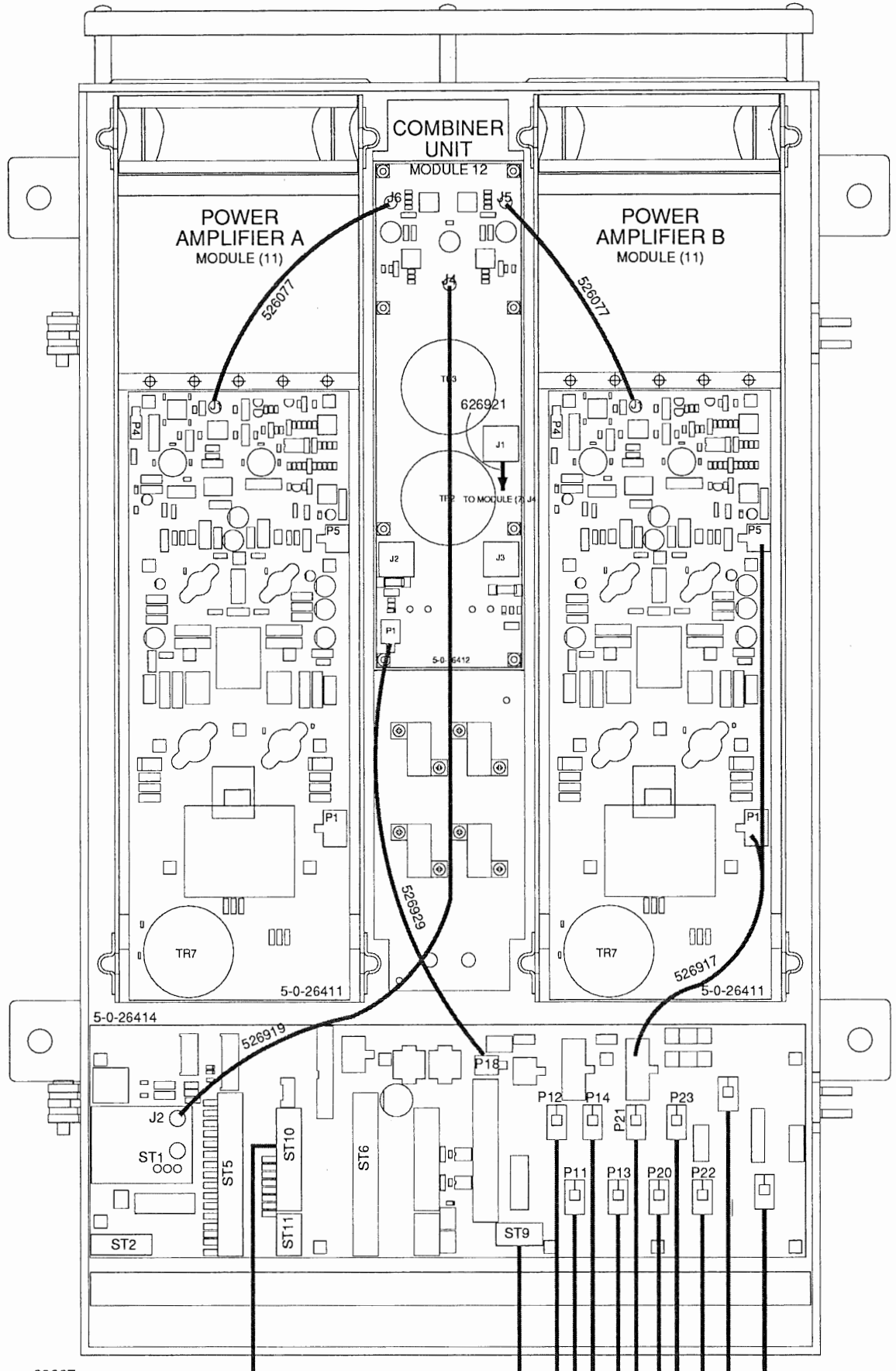

CONTENTS

3	SERVICE	3-1
3.1	ALIGNMENT INSTRUCTIONS	3-1
3.2	PROPOSAL FOR NECESSARY MEASURING INSTRUMENTS	3-1
3.3	TROUBLE SHOOTING	3-1
3.4	ADJUSTMENT PROCEDURE	3-1
3.5	NECESSARY ADJUSTMENTS AFTER REPAIR	3-2
3.6	PERFORMANCE CHECK	3-2

3 SERVICE

3.1 ALIGNMENT INSTRUCTIONS

INTRODUCTION

The measuring values indicated in chapter 5. CIRCUIT DESCRIPTION AND SCHEMATIC DIAGRAMS are typical values and as indicated it will be necessary to use instruments in absolute conformity with the below list:

3.2 PROPOSAL FOR NECESSARY MEASURINGS INSTRUMENTS

Tone Generator type PM5107	PHILIPS
Electronic Multimeter type PM2505	PHILIPS
RF Directional Wattmeter model 43	BIRD
Oscilloscope type PM321	PHILIPS
Dummy load 50 ohm/600W	
Power supply 21-32V,	50A (600W transmitter)
	100A (1200W transmitter)

3.3 TROUBLE SHOOTING

In this section you will find guidelines, which will help you to find the faulty component.

3.3.1 DC - CHECK

Check the voltage at:

TP2	3.0V +/- 0.5V
TP4	2.5V +/- 0.5V
TP3	3.0V +/- 0.5V
TP5	2.5V +/- 0.5V

3.3.2 RF - CHECK

Connect a 50 ohms dummy load to the output terminal ST3 on the connection board. select service programme SP-29-0 (see part I para 3.8).

Check the curve forms and the amplitudes at:

TP1	see para 5.1
TP2	see para 5.1
TP3	see para 5.1
TP6	see para 5.1
TP7	see para 5.1
TP8	see para 5.1
TP9	see para 5.1
TP10	see para 5.1
TP11	see para 5.1
TP12	see para 5.1
TP13	see para 5.1

3.3.3 CHECK OF DETECTORS

Select SP-29-0, and check the DC voltages at:

TP14	3V +/- 1V
TP15	3V +/- 1V

3.3.4 CHECK OF THE BALANCE LOAD

Disconnect the balance load and check with a ohm meter, that the balance load resistor are 100 ohm +/- 10 ohm

3.4 ADJUSTMENT PROCEDURE

Connect a 50 ohm dummy load to the output terminal ST3 on the connection board.

3.4.1 ADJUSTMENT OF THE BALANCE

Measure the RF voltage at TP13 with a oscilloscope, and adjust R35 to for minium voltage.

3.5 NECESSARY ADJUSTMENTS AFTER REPAIR

After change of a component in the power splitter you have to perform paragraph 3.4.1

3.6 PERFORMANCE CHECK

Perform the measurement described in paragraph 3.3.2.

CONTENTS

4	MECHANICAL DESCRIPTION	4-1
4.1	MECHANICAL ASSEMBLING / DISASSEMBLING AND UNITS LOCATION	4-1

4 MECHANICAL DESCRIPTION

4.1 MECHANICAL ASSEMBLING / DISASSEMBLING AND UNITS LOCATION

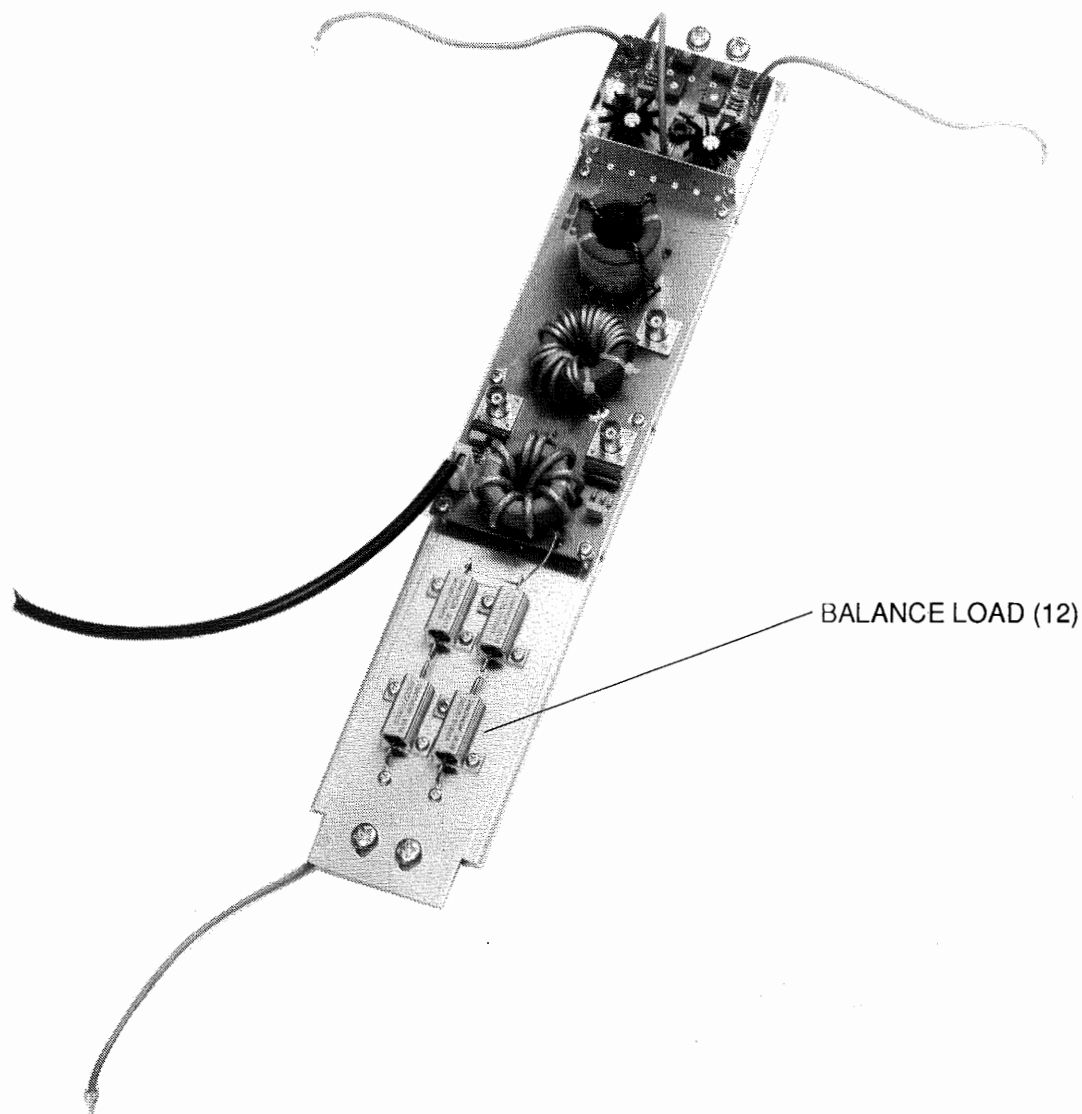

501141

CONTENTS

5 CIRCUIT DESCRIPTION AND SCHEMATIC DIAGRAMS

5.1 COMBINER (MODULE 12) PART NO. 626412

5-1

5 CIRCUIT DESCRIPTION AND SCHEMATIC DIAGRAMS

5.1 COMBINER (MODULE 12) PART NO. 626412

This module consists of the input splitter amplifier and output combiner.

The input splitter TR5 and the following amplifier (Q2 or Q1) have a gain of approx. 0 dB measured from J4 to J5 or J6. The gain can be adjusted by R35 (module A) or by R36 (module B).

The output combiner TR2 is followed by a 4:9 impedance transformer, which gives a load impedance of 50 ohm.

TR1 is a balun transformer which converts an unbalanced 100 ohm load to a balanced 100 ohm load, to absorb the unbalance in the two PA modules (A,B).

R1, R3, D1, R4 and C1 are the power detector for PA module A.

R5, R7, D2, R8 and C2 are the power detector for PA module B.

COMPONENT LOCATION COMBINER MODULE 12

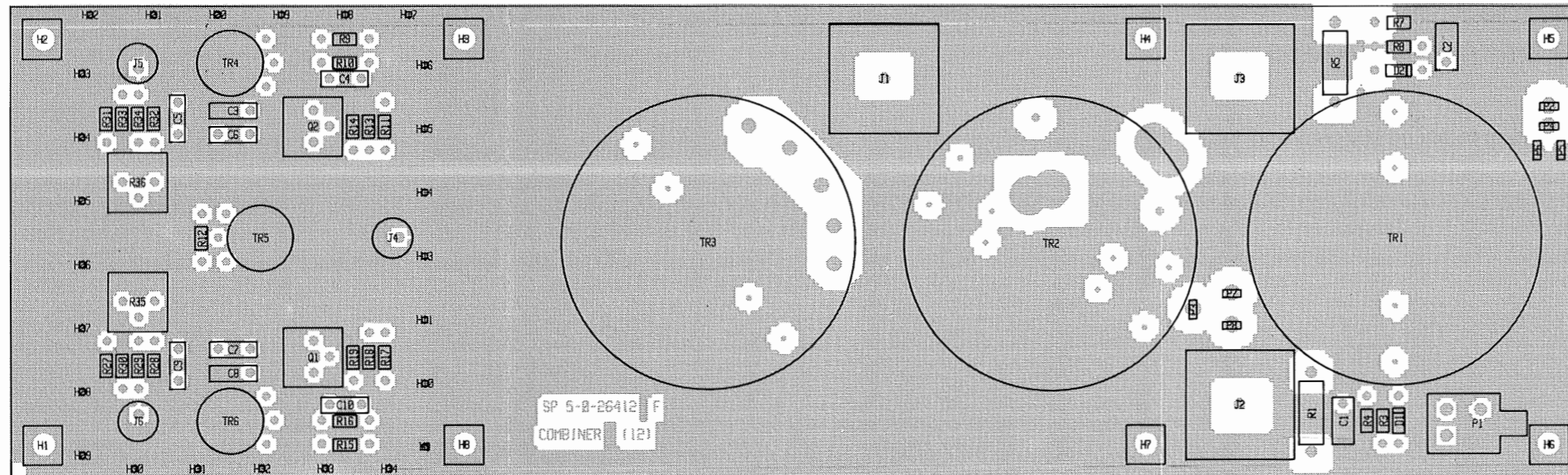

View from component side with upper side tracks.

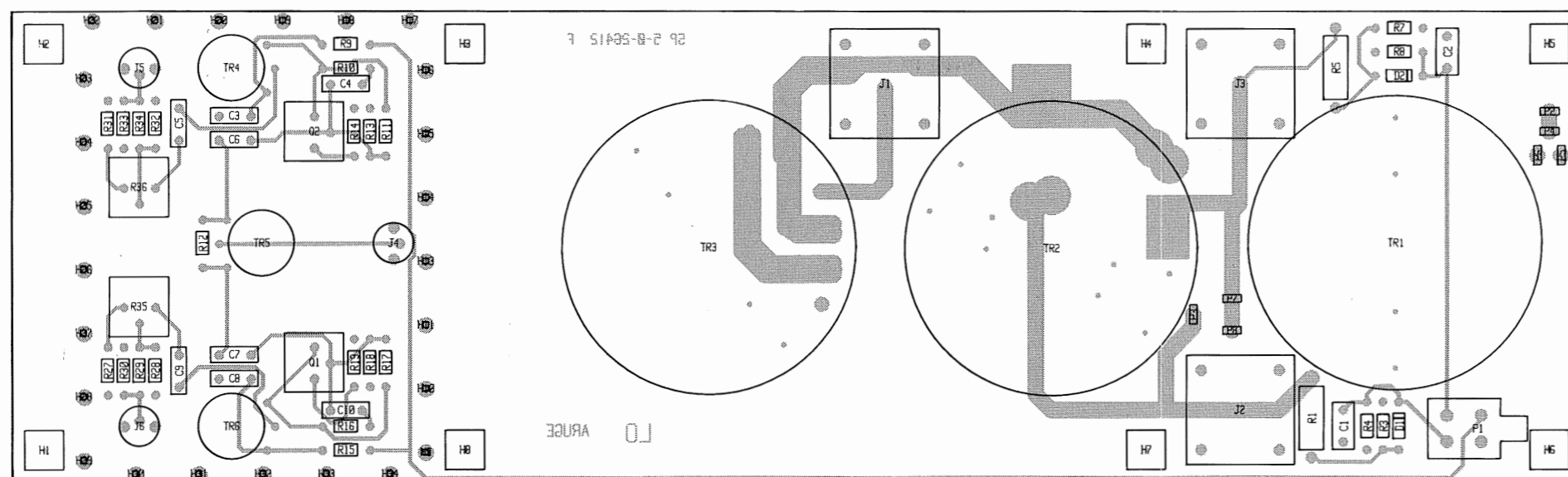

View from component side with lower side tracks.

COMBINER MODULE 12

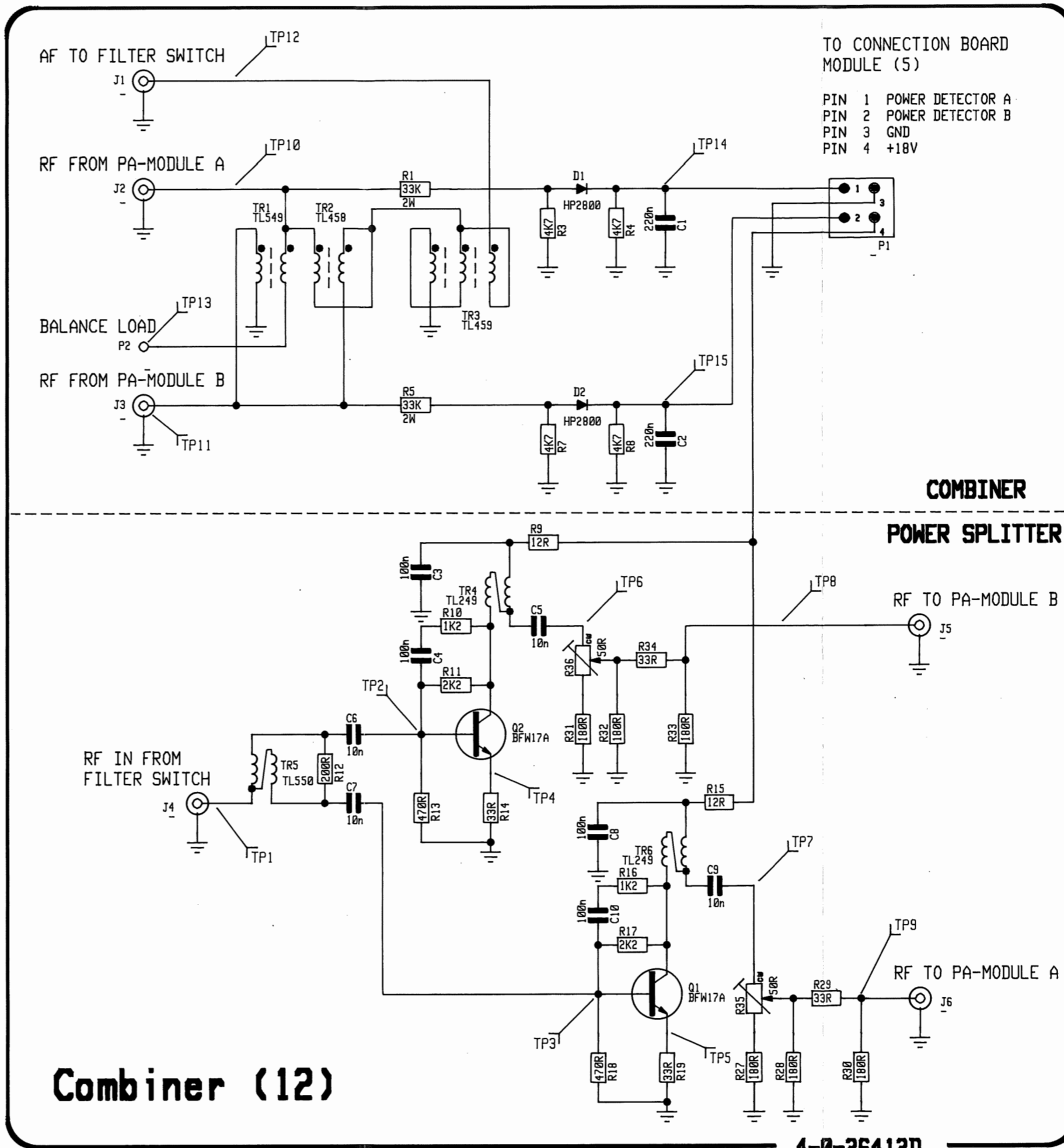

4-0-26412D

4-0-26412D

CONTENTS

6 PARTS LISTS

6-1

GRØN SIDE

6 PARTS LISTS

COMBINER UNIT 1200W		HF SSB PROGRAMME	ECI A/S	0-0-26394	726394
POSITION	DESCRIPTION		MANUFACTOR	TYPE	PART NO.
VARIOUS	COAX CABLE Ø3x23cm/BLUE		ECI A/S	3-0-26077	526077
VARIOUS	COAX CABLE Ø3x73cm		ECI A/S	0-0-26919	526919
VARIOUS	COAX CABLE Ø5x82cm		ECI A/S	0-0-26921	526921
VARIOUS	CONNECTION CABLE FOR	COMBINER T2135	ECI A/S	0-0-26929	526929
-12	COMBINER MODULE 12	T2135	ECI A/S	5-0-26412F / 4-0-26412D	626412
COMBINER MODULE 12		T2135	ECI A/S	5-0-26412F / 4-0-26412D	626412
POSITION	DESCRIPTION		MANUFACTOR	TYPE	PART NO.
C1-12	CAPACITOR MKT	220nF 10% 63VDC	PHILIPS	2222 370 78224	11.095
C2-12	CAPACITOR MKT	220nF 10% 63VDC	PHILIPS	2222 370 78224	11.095
C3-12	CAPACITOR MKT	0.1uF 10% 63VDC	PHILIPS	2222 370 78104	11.136
C4-12	CAPACITOR MKT	0.1uF 10% 63VDC	PHILIPS	2222 370 78104	11.136
C5-12	CAPACITOR MKT	10nF 20% 100VDC	PHILIPS	2222 370 38103	11.168
C6-12	CAPACITOR MKT	10nF 20% 100VDC	PHILIPS	2222 370 38103	11.168
C7-12	CAPACITOR MKT	10nF 20% 100VDC	PHILIPS	2222 370 38103	11.168
C8-12	CAPACITOR MKT	0.1uF 10% 63VDC	PHILIPS	2222 370 78104	11.136
C9-12	CAPACITOR MKT	10nF 20% 100VDC	PHILIPS	2222 370 38103	11.168
C10-12	CAPACITOR MKT	0.1uF 10% 63VDC	PHILIPS	2222 370 78104	11.136
D1-12	DIODE SCHOTTKY BARRIER	70V/15mA 1N5711/5082-2800	SGS-THOMSON	1N5711	27.500
D2-12	DIODE SCHOTTKY BARRIER	70V/15mA 1N5711/5082-2800	SGS-THOMSON	1N5711	27.500
J1-12	SOCKET BNC	PCB VERSION	ROSENBERGER	51K102-400 A4	78.444
J2-12	SOCKET BNC	PCB VERSION	ROSENBERGER	51K102-400 A4	78.444
J3-12	SOCKET BNC	PCB VERSION	ROSENBERGER	51K102-400 A4	78.444
J4-12	SOCKET COAX FOR PCB	VERTICAL	TAIKO	TMP-J01X-V6	78.518
J5-12	SOCKET COAX FOR PCB	VERTICAL	TAIKO	TMP-J01X-V6	78.518
J6-12	SOCKET COAX FOR PCB	VERTICAL	TAIKO	TMP-J01X-V6	78.518
P1-12	PLUG 4 POLES		MOLEX	39-28-1043	78.216
P2-12	SOLDER LUG	PCB VERSION	VOGT AG	01015/Bz-Sn	82.005
Q1-12	TRANSISTOR RF	BFW17A PNP TO-39	SGS	BFW17A	29.151
Q2-12	TRANSISTOR RF	BFW17A PNP TO-39	SGS	BFW17A	29.151
R1-12	RESISTOR PMF	33k OHM 5% 2W	PHILIPS	2322 194 13333	04.229
R3-12	RESISTOR MF	4k7 OHM 5% 0.33W	PHILIPS	2322 187 73472	02.488
R4-12	RESISTOR MF	4k7 OHM 5% 0.33W	PHILIPS	2322 187 73472	02.488
R5-12	RESISTOR PMF	33k OHM 5% 2W	PHILIPS	2322 194 13333	04.229
R7-12	RESISTOR MF	4k7 OHM 5% 0.33W	PHILIPS	2322 187 73472	02.488
R8-12	RESISTOR MF	4k7 OHM 5% 0.33W	PHILIPS	2322 187 73472	02.488
R9-12	RESISTOR MF	12 OHM 5% 0.33W	PHILIPS	2322 187 73129	02.426
R10-12	RESISTOR MF	1k2 OHM 5% 0.33W	PHILIPS	2322 187 73122	02.474
R11-12	RESISTOR MF	2k2 OHM 5% 0.33W	PHILIPS	2322 187 73222	02.480
R12-12	RESISTOR MF	200 OHM 5% 0.33W	PHILIPS	2322 187 73201	02.455
R13-12	RESISTOR MF	470 OHM 5% 0.33W	PHILIPS	2322 187 73471	02.464
R14-12	RESISTOR MF	33 OHM 5% 0.33W	PHILIPS	2322 187 73339	02.436
R15-12	RESISTOR MF	12 OHM 5% 0.33W	PHILIPS	2322 187 73129	02.426
R16-12	RESISTOR MF	1k2 OHM 5% 0.33W	PHILIPS	2322 187 73122	02.474
R17-12	RESISTOR MF	2k2 OHM 5% 0.33W	PHILIPS	2322 187 73222	02.480
R18-12	RESISTOR MF	470 OHM 5% 0.33W	PHILIPS	2322 187 73471	02.464
R19-12	RESISTOR MF	33 OHM 5% 0.33W	PHILIPS	2322 187 73339	02.436
R27-12	RESISTOR MF	180 OHM 5% 0.33W	PHILIPS	2322 187 73181	02.454
R28-12	RESISTOR MF	180 OHM 5% 0.33W	PHILIPS	2322 187 73181	02.454
R29-12	RESISTOR MF	33 OHM 5% 0.33W	PHILIPS	2322 187 73339	02.436
R30-12	RESISTOR MF	180 OHM 5% 0.33W	PHILIPS	2322 187 73181	02.454
R31-12	RESISTOR MF	180 OHM 5% 0.33W	PHILIPS	2322 187 73181	02.454
R32-12	RESISTOR MF	180 OHM 5% 0.33W	PHILIPS	2322 187 73181	02.454
R33-12	RESISTOR MF	180 OHM 5% 0.33W	PHILIPS	2322 187 73181	02.454
R34-12	RESISTOR MF	33 OHM 5% 0.33W	PHILIPS	2322 187 73339	02.436
R35-12	PRESET CERMET	50 OHM 10% 0.5W	* BOURNS	3386P-1-500	07.882
R36-12	PRESET CERMET	50 OHM 10% 0.5W	* BOURNS	3386P-1-500	07.882
TR1-12			ECI A/S	6-0-26461B	400549
TR2-12	OUTPUT POWER COMBINER	TL458	ECI A/S	6-0-25043A	400458
TR3-12	OUTPUT IMPEDANCE TRANSF.	TL459	ECI A/S	6-0-25044D	400459
TR4-12	TRANSFORMER	TL249	ECI A/S	6-0-21572	400249
TR5-12	INPUT POWER SPLITTER	TL550	ECI A/S	6-0-26462	400550
TR6-12	TRANSFORMER	TL249	ECI A/S	6-0-21572	400249

TECHNICAL MANUAL FOR POWER SUPPLY UNIT 24V DC 600W
(N2170) PART NO. 726420

CONTENTS

1	GENERAL INFORMATION	
1.1	INTRODUCTION	1-1
1.2	PRINCIPLE OF OPERATION	1-1
2	INSTALLATION	
2.1	ELECTRICAL CONNECTIONS AND ASSEMBLING	2-1
3	SERVICE	
3.1	MAINTENANCE	3-1
3.2	RECOMMENDED TEST EQUIPMENT	3-1
3.3	TROUBLE SHOOTING	3-1
3.4	PERFORMANCE CHECK	3-2
3.5	NECESSARY CHECK AND ADJUSTMENT AFTER REPAIR	3-3
4	MECHANICAL DESCRIPTION	
4.1	MECHANICAL ASSEMBLING / DISASSEMBLING AND UNITS LOCATION	4-1
5	CIRCUIT DESCRIPTION AND SCHEMATIC DIAGRAMS	
5.1	INPUT FILTER (MODULE 1) PART NO. 626421	5-1
5.2	28V & 42V REGULATOR (MODULE 2) PART NO. 626422	5-1
5.3	CONVERTER CONTROLLER (MODULE 3) PART NO. 626423	5-11
5.4	CONVERTER (MODULE 4) PART NO. 626424 FOR 42V CONVERTER PART NO. 726424 FOR 28V CONVERTER	5-15
6	PARTS LISTS	

CONTENTS

1	GENERAL INFORMATION	1-1
1.1	INTRODUCTION	1-1
1.2	PRINCIPLE OF OPERATION	1-1

1 GENERAL INFORMATION

1.1 INTRODUCTION

This section gives you all necessary information to make service of this unit down to component level.

1.2 PRINCIPLE OF OPERATION

The power supply is divided into four separate converters with individual converter controllers, a common regulator module and a common filter module. Three of the converters produce the 42V output voltage and the last converter produces the 28V output voltage.

The output voltages can be turned on/off by external signals from the TX processor in the transmitter.

The 42V converters are working at the same frequency but with a 120° phase shift in order to reduce the ripple current in the input capacitors and to reduce the output ripple. The ripple frequency is therefore 150 kHz instead of 50 kHz.

Each of the three converters is working as a current mode push-pull forward converter. The converter compares the output current (reflected by the transformer) with a control voltage from the regulator module, so that all the converters deliver the same output current, current sharing. When the control voltage is changed, the output currents are changed and thus also the output voltage.

The 28V converter is also working as a current mode push-pull forward converter and the frequency is the same as for the 42V converters to prevent sub harmonics.

All fuses on the converters are monitored by the regulator module and if one is blown, the power supply is shut down.

If the input supply voltage is too low or high, the converters automatically stop.

When the converters start or restart, the output voltages slowly rises, soft starts.

A blower is switches on simultaneously with the 42V output to cool the power supply.

In case of blower failure, a thermal breaker shuts down the 42V output if heatsink temperature exceeds 90°C.

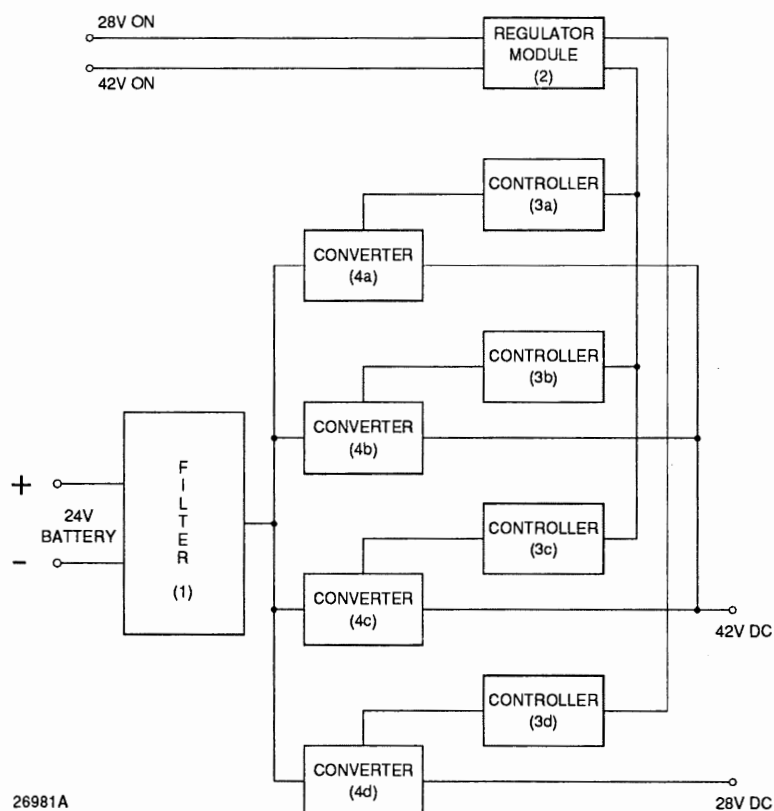

CONTENTS

2	INSTALLATION	2-1
2.1	ELECTRICAL CONNECTIONS AND ASSEMBLING	2-1

2 INSTALLATION

2.1 ELECTRICAL CONNECTION AND ASSEMBLING

CONNECTION TO N2170 600W

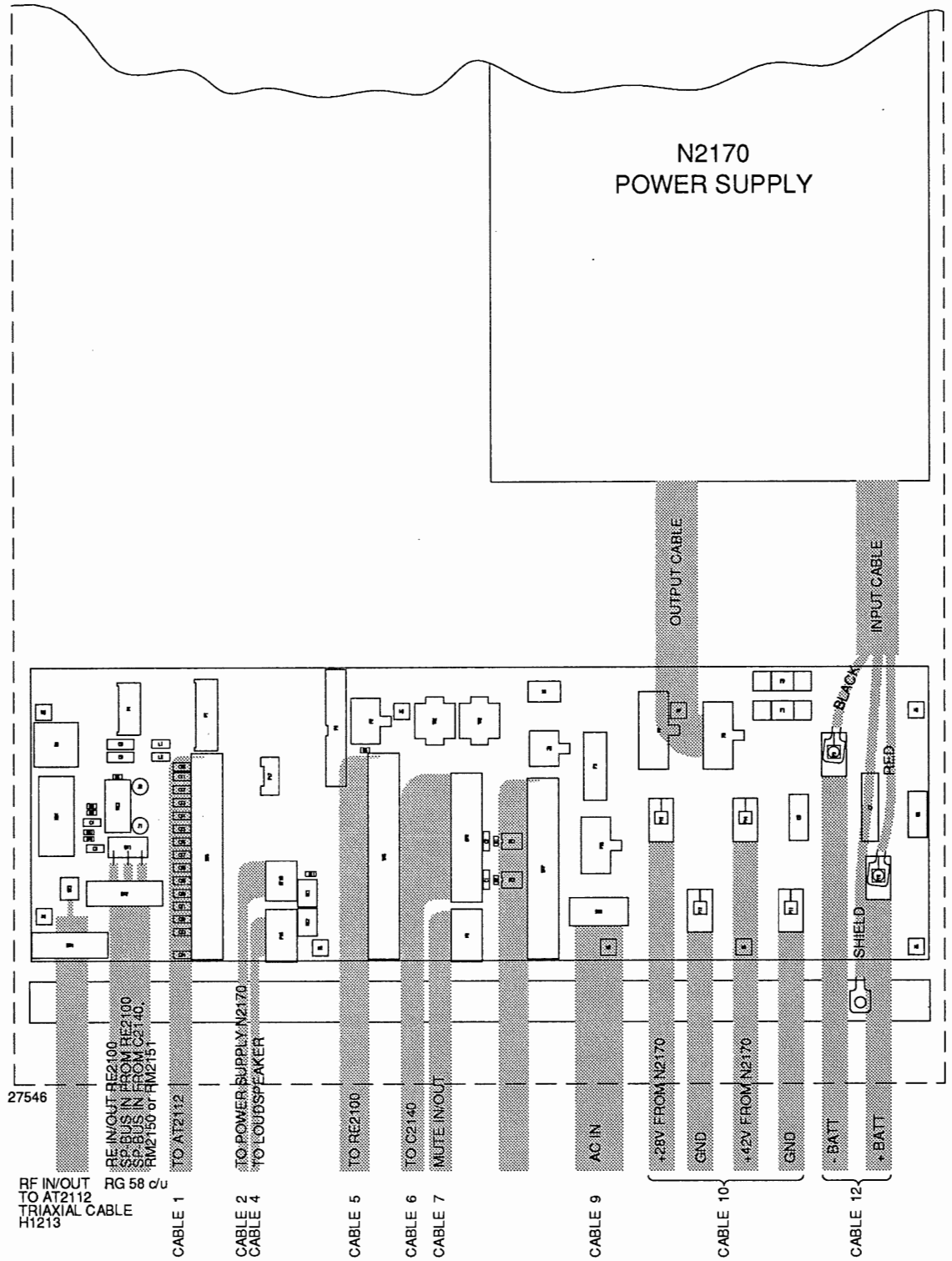

FOR CABLE DIMENSIONS: SEE PART I CHAPTER 2. INSTALLATION

CONNECTION TO N2170 SINGLE

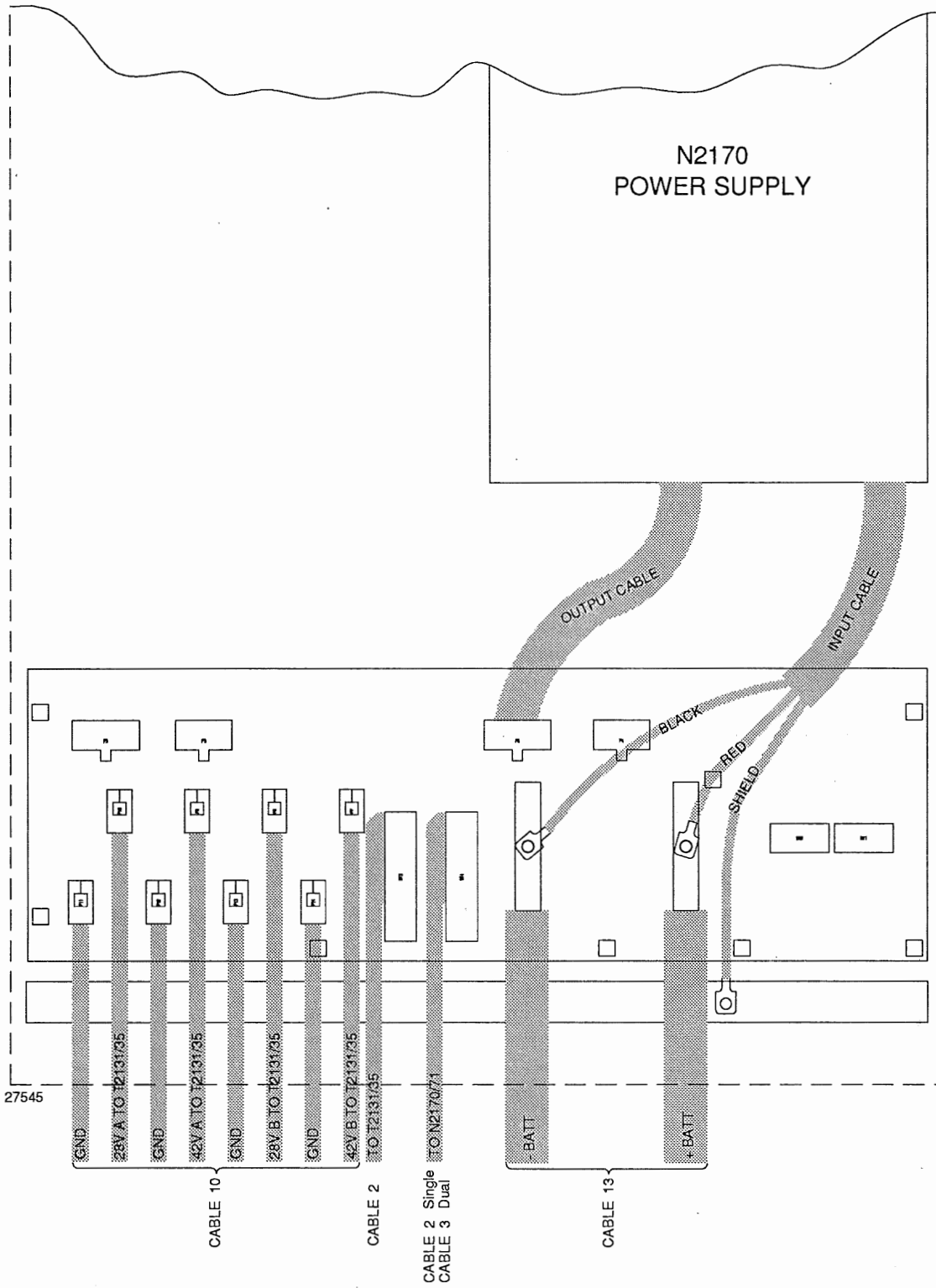

CONNECTION TO N2170 DUAL

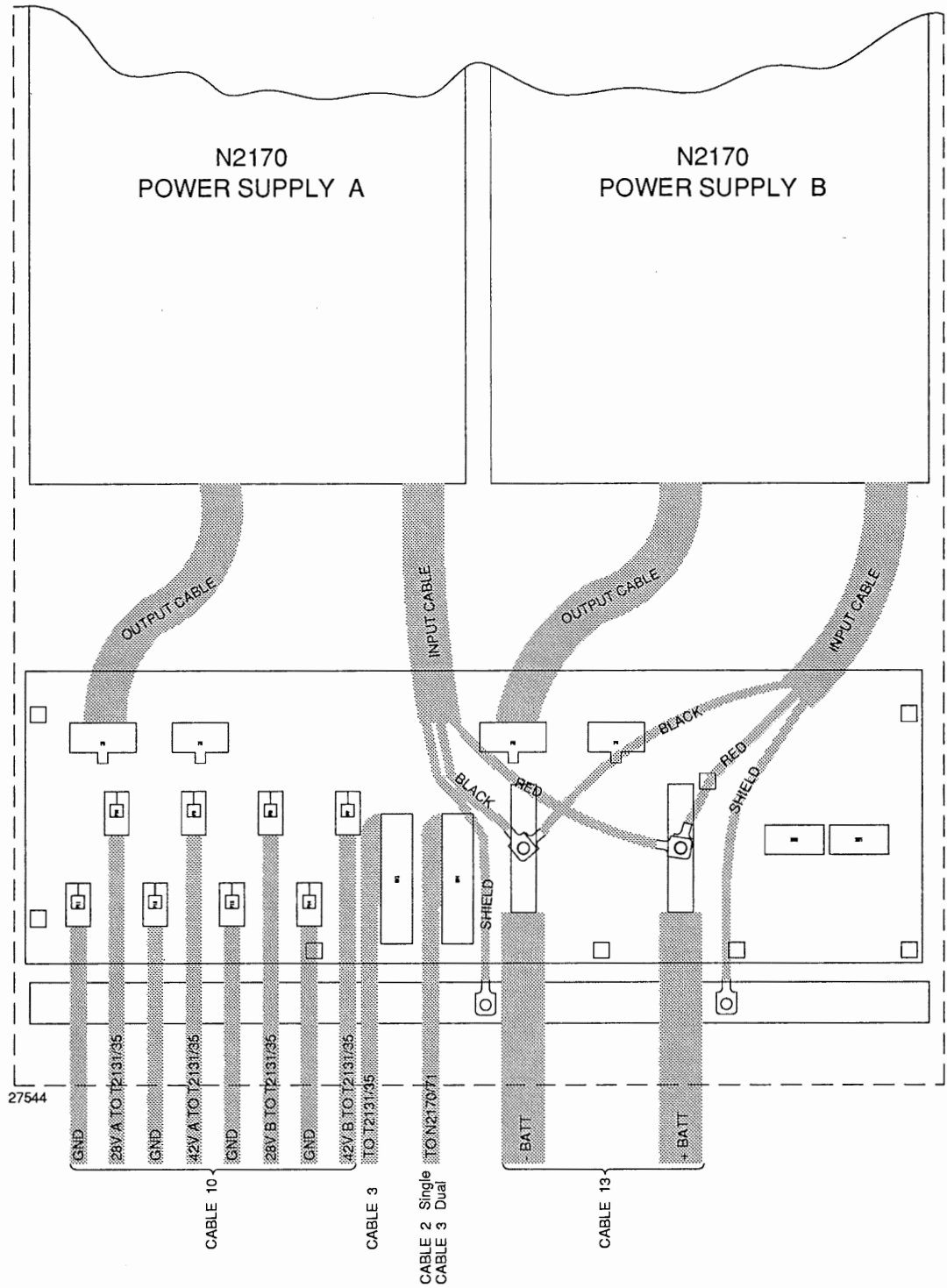

CONTENTS

3	SERVICE	3-1
3.1	MAINTENANCE	3-1
3.2	RECOMMENDED TEST EQUIPMENT	3-1
3.3	TROUBLE SHOOTING	3-1
3.4	PERFORMANCE CHECK	3-2
3.5	NECESSARY CHECK AND ADJUSTMENT AFTER REPAIR	3-3

3 SERVICE

3.1 MAINTENANCE

When the SAILOR N2170 has been correctly installed, the maintenance of the power supply can, dependent on the environments and working hours, be reduced to a performance check at the service workshop at intervals not exceeding 5 years.

A performance check list is enclosed in the section 3.4. PERFORMANCE CHECK.

Also inspect cables and plugs for mechanical defects and corrosion.

Any repair of the set should be followed by a check described in the section 3.5. NECESSARY ADJUSTMENT AND CHECK AFTER REPAIR.

3.2 RECOMMENDED TEST EQUIPMENT

Multimeter	Philips PM2518X
Oscilloscope	Philips PM3214

3.3 TROUBLE SHOOTING

Trouble shooting, repair and check of the N2170 should only be performed by persons, who have the sufficient technical knowledge and the necessary test equipment at their disposal.

Some faults require that each module can be checked separately. To check the 28V & 42V regulator (module 2), all cables are removed from all converter controller modules. Some measurements can now be done, but notice, that the voltages on the diagram do not correspond to this case.

In order to check only one converter module, the cables to the converter controller modules must be removed, except for the module in question. In order to switch on the module, it is necessary to cancel the fuse supervising circuit on the 28V & 42V regulator (module 2). This can be done by short-circuiting the resistor R97-2. One converter module can handle a load up to 9A.

1. No output at all:
 - a) Input voltage (battery) is too low or too high.
 - b) A voltage transient on the input voltage has occurred. Try to switch off and on the 28V output to reset the shut-down function.
 - c) A voltage transient on the output has occurred. Switch-off and on the 28V output to reset.
 - d) A failure in the control loop has occurred and triggered the shut-down circuit. Execute chapter 3.4.2. PERFORMANCE CHECK OF THE OUTPUT VOLTAGES.

2. The 42V output drops if loaded:
 - a) One of the converter modules is out of order.
 - b) One of the converter modules has shut down.
 - c) Wrong adjustment of current limiter.

3. No 42V output voltage:
 - a) The 28V output is not switched on.
 - b) A failure in the control loop has caused an overvoltage which triggers the shut-down circuit.
 - c) The thermal breaker TB1-3 is activated because the heat sink has too high temperature. The blower may be out of order.

3.4 PERFORMANCE CHECK

Any value, which differs too much from the values given in this chapter, should lead to a repair or an adjustment of the circuit or module in question.

Hints to locate some faults are given in the chapter 3.3. TROUBLE SHOOTING.

To handle the performance check in an easy way, it is recommended to connect the N2170 to a disconnected connection board (module 5 or module 13).

To make the internal voltages for the regulator module, it is necessary to connect the 18V wire from N2170 to a separate power supply, capable of delivering 18V at 0.2A, with the minus connected to N2170 chassis. The 18V supply can also be used to switch the outputs on and off by connecting the 18V to 28V ON and 42V ON wires to N2170. The 28V has to be switched on first before the 42V is switched on.

3.4.1 PERFORMANCE CHECK OF OUTPUT VOLTAGES

1. To get a proper regulation, connect small dummy loads to the outputs. For 42V output a resistor of 330 ohm/6W and for 28V output a resistor of 220 ohm/6W is sufficient.
2. Connect 24V to the battery input connection of N2170.
3. Connect 18V to the 28V ON and 42V ON terminals to switch on the outputs.
4. By means of a voltmeter, read the 42V output to $42.2V \pm 0.5V$ DC and the 28V output to $27.5V \pm 0.5V$ DC.
5. Check also that the blower is running while both outputs are switched on.
6. A scope picture of the switching voltage across the switching transistors for the 42V converters shows not a fine square wave, but a mixture of square waves and spikes. This is normal because of the working principle and because of small loads.

3.4.2 PERFORMANCE CHECK OF PROTECTION CIRCUITS

1. A variable power supply delivering voltages between 14V and 37V DC is connected to the battery input of N2170.
2. Small dummy loads are connected to the outputs.
3. Set the input voltage to 14V and switch on the outputs. The outputs should not be able to switch on.
4. Set the input voltage to 17V. Check that the outputs are now switched on and within the limits.
5. Set the input voltage to 37V. Check that the outputs are shut down.
6. Set the input voltage to 19V. Switch off and on the 28V output to reset the shut-down circuit.
7. Short-circuit for a second the opto-coupler OC1-2 pin 4 and 5, and OC3-2 pin 4 and 5. Watch that the outputs are going down. Switch off and on the 28V output to reset.
8. Check with an oscilloscope to U9-2 pin 3 the frequency to approx. 120 kHz square wave.

9. Remove the cable from one of the converter controllers (module 3) and watch that the 42V is going down. (Test of fuse supervising circuit).

3.4.3 PERFORMANCE CHECK OF CURRENT LIMITERS

1. Connect a dummy load of 1.46 ohm/1000W to the 42V output. It can be made by parallelling several power resistors.
2. Connect a dummy load of 3.68 ohm/200W to the 28V output.
3. Connect a power supply or a battery, capable of delivering 26V DC at 65 A, to the battery input of N2170.
4. Switch on both outputs and read with a voltmeter the 42V output to $36.5V \pm 1V$ DC. Read also the 28V output to $26.5V \pm 0,5V$ DC.
5. Check with an oscilloscope that the output ripple of the 42V output is less than $1.5V_{pp}$ apart from the voltage spikes at full load of 25A.
6. Check with an oscilloscope that the output ripple of the 28V output is less than $1.5V_{pp}$ apart from the voltage spikes at full load of 7.2A.
7. A scope across the switching transistors of the 42V converters shows square waves with a little jitter. All three 42V converters must be working when fully loaded.

3.5 NECESSARY CHECK AND ADJUSTMENT AFTER REPAIR

Change or Repair of the Input Filter (Module 1) or of the 28V & 42V Regulator (Module 2):

Execute chapter 3.4.1. PERFORMANCE CHECK OF OUTPUT VOLTAGES and adjust if necessary the 28V output voltage to $27.5V \pm 0,2V$ DC with R29-2 and the 42V output voltage to $42.2V \pm 0.2V$ DC with R25-2.

Execute chapter 3.4.3. PERFORMANCE CHECK OF CURRENT LIMITERS and adjust if necessary the 42V current limiter to $36.5V \pm 0.2V$ DC with R23-2, and the 28V current limiter to $26.5V \pm 0.2V$ DC with R27-2.

Notice! During adjustments of the current limiters the cover of N2170 is open which means that the adjustment is drifting because of less cooling of the current sense resistors on the input filter module. Therefore the adjustment must be done quickly to close the cover. Let it run for a while and then readjust.

Execute chapter 3.4.2. PERFORMANCE CHECK OF PROTECTION CIRCUITS.

Change or Repair of Converter Controller (Module 3) or of Converter (Module 4).

Execute chapter 3.4.2. PERFORMANCE CHECK OF PROTECTION CIRCUITS.

Execute chapter 3.4.3. PERFORMANCE CHECK OF CURRENT LIMITERS and adjust if necessary as described above for the change or repair of the input filter.

Notice! If a converter module is used as 28V converter, check that the zener diode D9-4 (8.2V) is placed for overvoltage protection. Check at the same time that any of the three 42V converters does not contain D9-4. If so, it must be removed.

CONTENTS

4	MECHANICAL DESCRIPTION	4-1
4.1	MECHANICAL ASSEMBLING / DISASSEMBLING AND UNITS LOCATION	4-1

4 MECHANICAL DESCRIPTION

4.1 MECHANICAL ASSEMBLING / DISASSEMBLING AND UNITS LOCATION

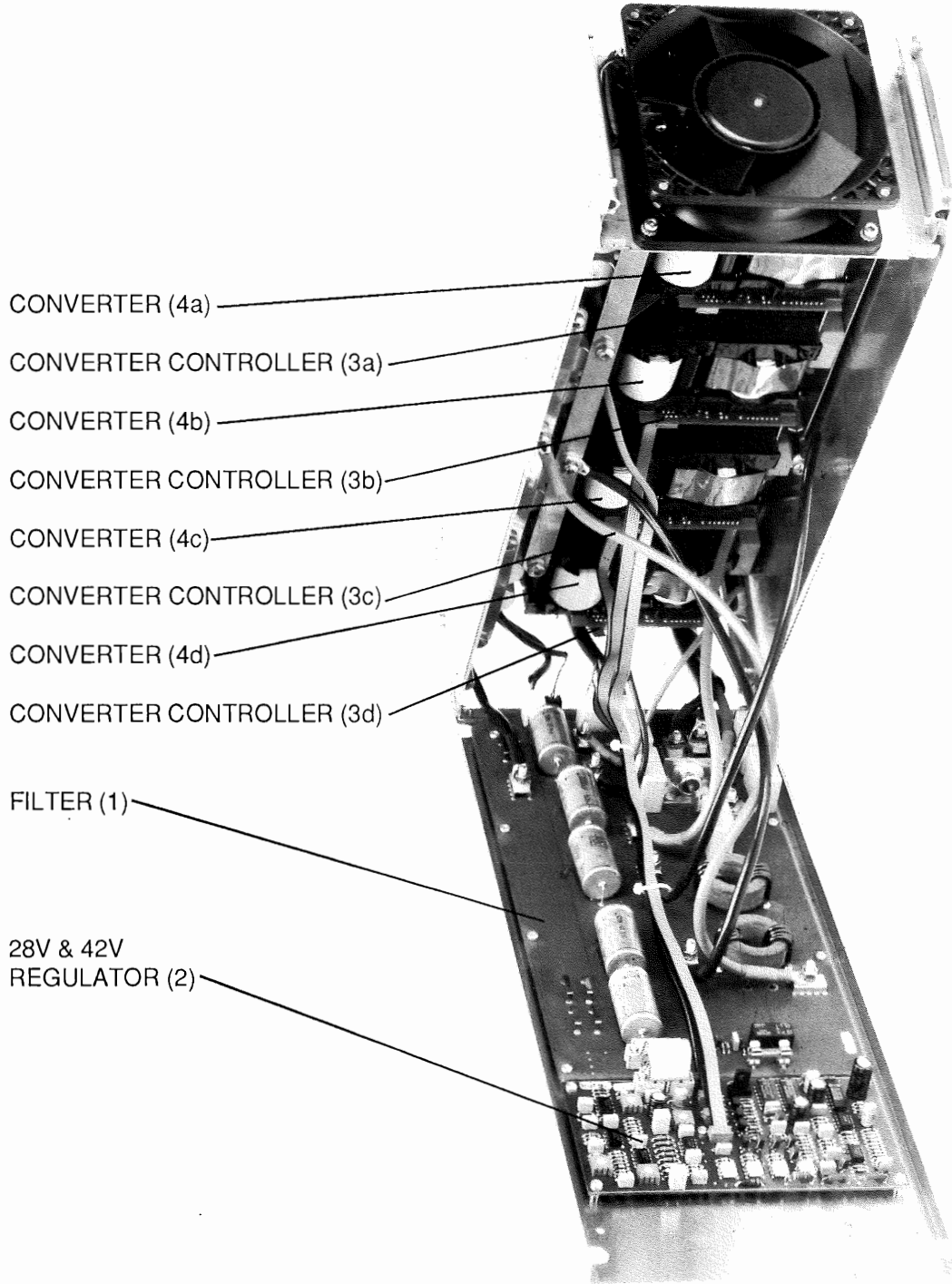

501297

CONTENTS

5	CIRCUIT DESCRIPTION AND SCHEMATIC DIAGRAMS	
5.1	INPUT FILTER (MODULE 1) PART NO. 626421	5-1
5.2	28V & 42V REGULATOR (MODULE 2) PART NO. 626422	5-1
5.3	CONVERTER CONTROLLER (MODULE 3) PART NO. 626423	5-11
5.4	CONVERTER (MODULE 4) PART NO. 626424 FOR 42V CONVERTER PART NO. 726424 FOR 28V CONVERTER	5-15

5 CIRCUIT DESCRIPTION AND SCHEMATIC DIAGRAMS

5.1 INPUT FILTER (MODULE 1) PART NO. 626421

The 3-phased output voltage from the three 42V converters are connected at the input filter module. The voltage is filtered by the capacitors C1 to C4. A 42V voltage sense signal is passed on to the regulator module.

The 42V output current is sensed by R1 to R4 and passed on to the regulator module.

The 28V output voltage from the 28V converter is connected to the input filter module. The output is filtered by the capacitors C5. A 28V voltage sense signal is passed on to the regulator module.

The 28V output current is sensed by R5 to R7 and passed on to the regulator module.

The 24V DC supply from the battery is filtered by the EMI filter formed by C6, C7, C8, C9, C10, TR1, and TR2 and passed on to the four converters.

In case of reverse polarity of the battery, the diode D2 blows the fuse F2.

The relay RE1 connects the 24V DC supply voltage to the regulator module. The 18V supply voltage to the relay comes from the transmitter. The TX processor turns on/off the regulator module via the 28V ON signal.

The wires 42V ON and 28V ON are used by the TX processor in the transmitter to turn the 42V output voltage and the 28V output voltage on/off.

A thermostat TB1 is connected in series with the 42V ON signal. In case of too high temperature on the heatsink, this thermostat disconnects the 42V ON signal.

COMPONENT LOCATION INPUT FILTER MODULE 1

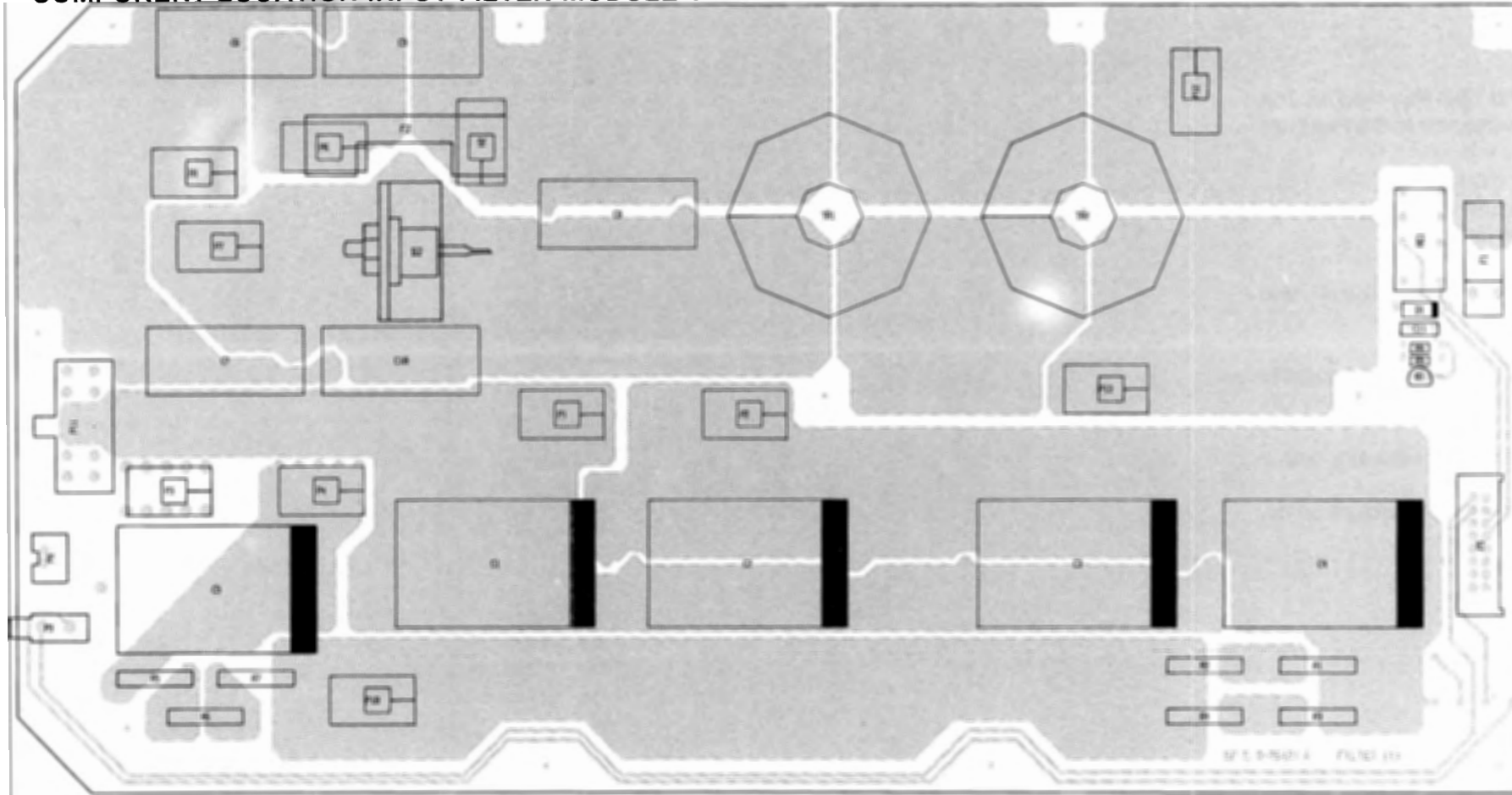

view from component side with upper side tracks

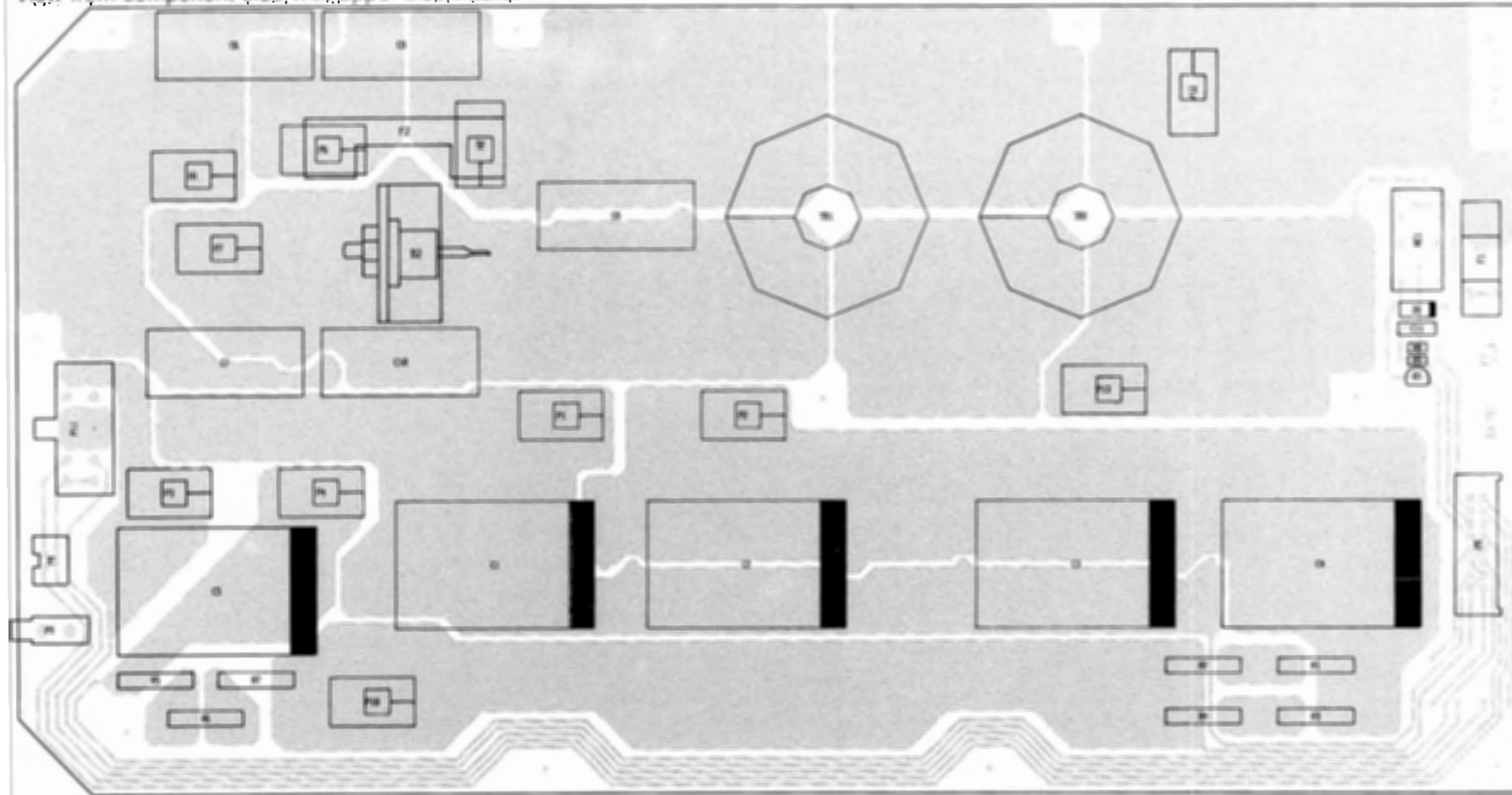

View from component side with lower side tracks.

INPUT FILTER MODULE 1

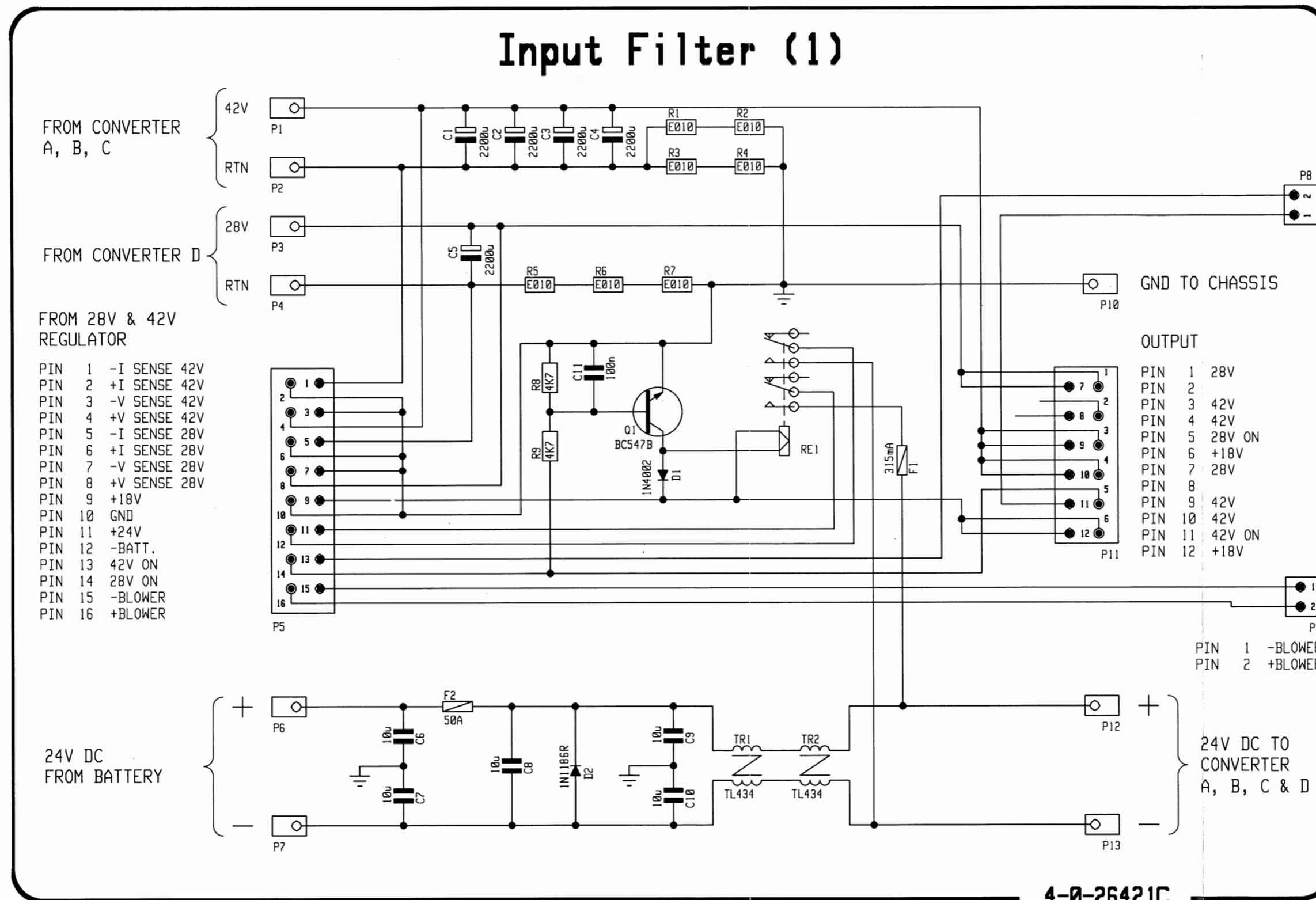

This diagram is valid for PCB rev. 26421A

5.2 28V & 42V REGULATOR (MODULE 2) PART NO. 626422

INTERNAL SUPPLY

The 24V supply voltage from the battery via the input filter module is used as internal supply voltages on the primary side of the regulator module. The 13V supply is produced by R54 and D9. The 9.1V supply is produced by R48 and D7. The 6.2V reference voltage comes from R53 and D6. The capacitors C22, C17 and C18 are decoupling capacitors.

The 18V supply voltage from the transmitter via the input filter module is used as the internal supply on the secondary side of the regulator module. The 18V is used to make the internal 6.2V reference voltage by means of R17 and D1. The capacitors C9, C10 and C11 are decoupling capacitors.

CLOCK FREQUENCY CIRCUIT

The IC U7 is an astable multivibrator where the oscillation frequency (approx. 300 kHz) is fixed by R58 and C20. The output signal is then divided by 3 by the Johnson counter U8. This counter produces the three 100 kHz pulses with 120° phase shift. The three clock signals are buffered by U9 and sent to the converter controller modules. The clock for the 28V converter follows one of the 42V converter clocks.

42V SUPPLY VOLTAGE LOOP

The 42V supply voltage is sensed on the input filter module and led to the common-mode amplifier R3, R4, R11, R12, C3, C4 and U2,1. The output voltage from this amplifier is divided by R19, R24 and R25 and compared with the reference voltage. The error voltage is then amplified by R31, R35 and U2,2. This signal is then OR-ed together with the current limit signal and led to Q1. The transistor Q1 converts the voltage signal into a current signal. This current signal drives the optodiode of OC1.

The collector of the optocoupler of OC1 is connected to R60. This resistor converts the current signal into a voltage signal again. The signal is then amplified by R64, R65, R66, C23 and U5,2. The signal is then buffered by U5,1 and used as the control voltage for all three 42V converters.

The potentiometer R25 is used for adjusting the 42V output voltage.

42V ON AND SOFT START

The function of the transistor Q1 is turned on/off by the optocoupler OC2. When the signal 42V ON from the transmitter goes high, the transistor Q10 goes on and turns OC2 on. OC2 then activates Q1. If Q1 is off, then the voltage on the collector of OC1 goes high. This voltage is sensed by Q9 via R89 and R91. If this voltage is high, then Q9 short-circuits the control voltage via D12 and R75. The 42V supply then stops. When Q9 turns off, the control voltage will slowly increase, controlled by the soft start capacitor C25. The converters always start in a soft start mode.

When 42V ON goes high, the transistor Q10 turns the transistor Q3 on. This transistor turns on the blower BL1 on so that the blower always runs when the 42V output voltage is on.

UNDERVOLTAGE

The Q9 transistor can be turned on by the battery supply undervoltage control circuit, R55, R56, R63, R68, R69 and U6,2. D8 protects the U6,2 in case of voltage transients on the supply voltage. This circuit ensures that the input supply is correct before the converters start, or stops the converters if the battery voltage falls below approx. 16V.

FUSE CONTROL

The fuses on the converter modules are checked by the transistors Q5 to Q8 together with their OR-ing diodes. If a fuse is blown, then the fuse signal goes low and the OR-ing resistor pulls the control voltage down via the transistor. The 42V output then stops. This is done to protect the input and output capacitors against the high ripple currents due to the missing phase.

42V OUTPUT CURRENT LIMITER

The output current is sensed on the input filter module and led to the common-mode amplifier R1, R2, R9, R10, C1, C2 and U1,1. The signal is compared with the reference voltage. If the current signal is higher than the reference voltage, the high gain amplifier takes over the control of Q1 and limits the output current. The current limit is set by R23.

28V VOLTAGE LOOP

The 28V supply voltage is sensed on the input filter module and led to the common-mode amplifier R7, R8, R15, R16, C7, C8 and U4,2. The output voltage from this amplifier is divided by R21, R28 and R29 and compared with the reference voltage. The error voltage is then amplified by R33, R37 and U4,1. This signal is then OR-ed together with the current limit signal and led to Q2. The transistor Q2 converts the voltage signal into a current signal. This current signal drives the optodiode of OC3.

The collector of the optotransistor of OC3 is connected to R49. This resistor converts the current signal into a voltage signal again. The signal is then amplified by R52, R57, R59, C19 and U6,1 and used as the control voltage for the 28V converter controller.

The potentiometer R29 is used for adjusting the 28V output voltage.

28V ON AND SOFT START

The function of the transistor Q2 is turned on/off by the optocoupler OC4. When signal 28V ON from the transmitter goes high, the transistor Q11 goes on and turns OC4 on. OC4 then activates Q2. If Q2 is off, then the voltage on the collector of OC3 goes high. This voltage is sensed by Q4 via R88 and R71. If this voltage is high then Q2 short-circuits the control voltage via R74. The 28V then stops. When Q4 turns off, the control voltage will slowly increase controlled by the soft start capacitor C24. The converters always start in a soft start mode.

28V OUTPUT CURRENT LIMITER

The output current is sensed in the input filter module and led to the common-mode amplifier R5, R6, R13, R14, C5, C6 and U3,1. The signal is compared with the reference voltage. If the current signal is higher than the reference voltage, the high gain amplifier takes over the control of Q2 and limits the output current. The current limit is set by R27.

COMPONENT LOCATION 28V & 42V REGULATOR MODULE 2

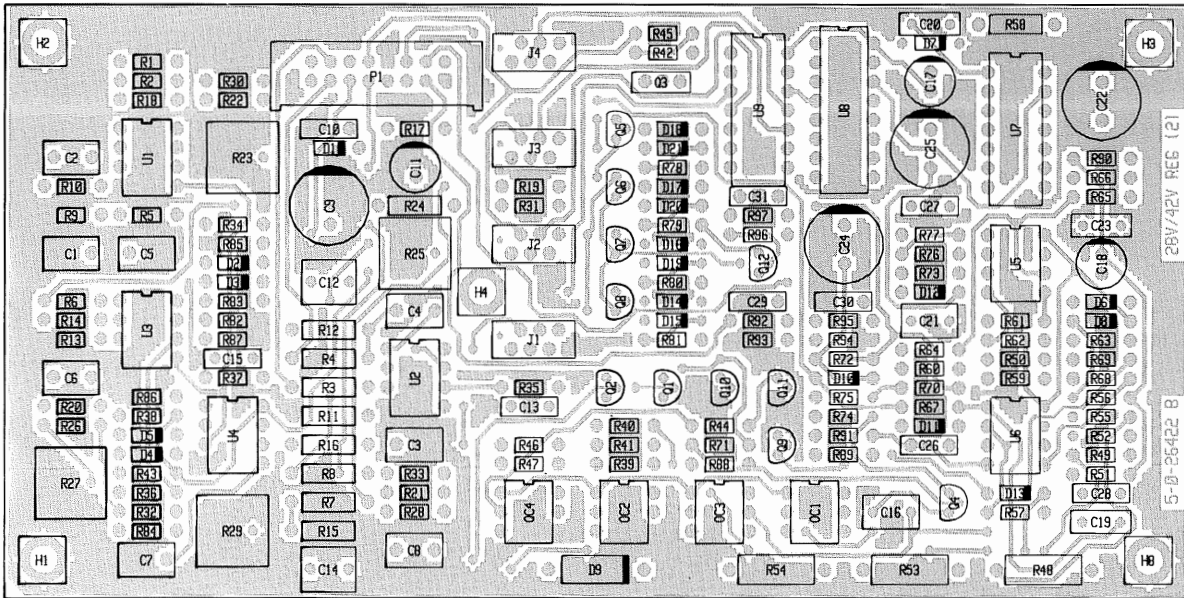

View from component side with upper side tracks.

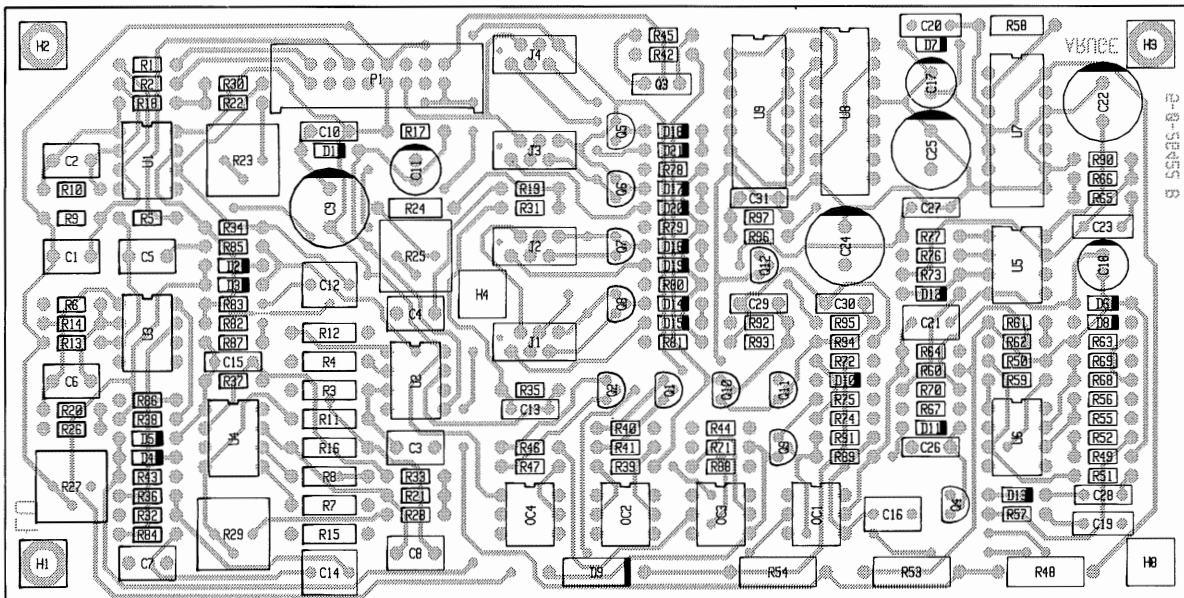

View from component side with lower side tracks.

28V & 42V REGULATOR MODULE 2

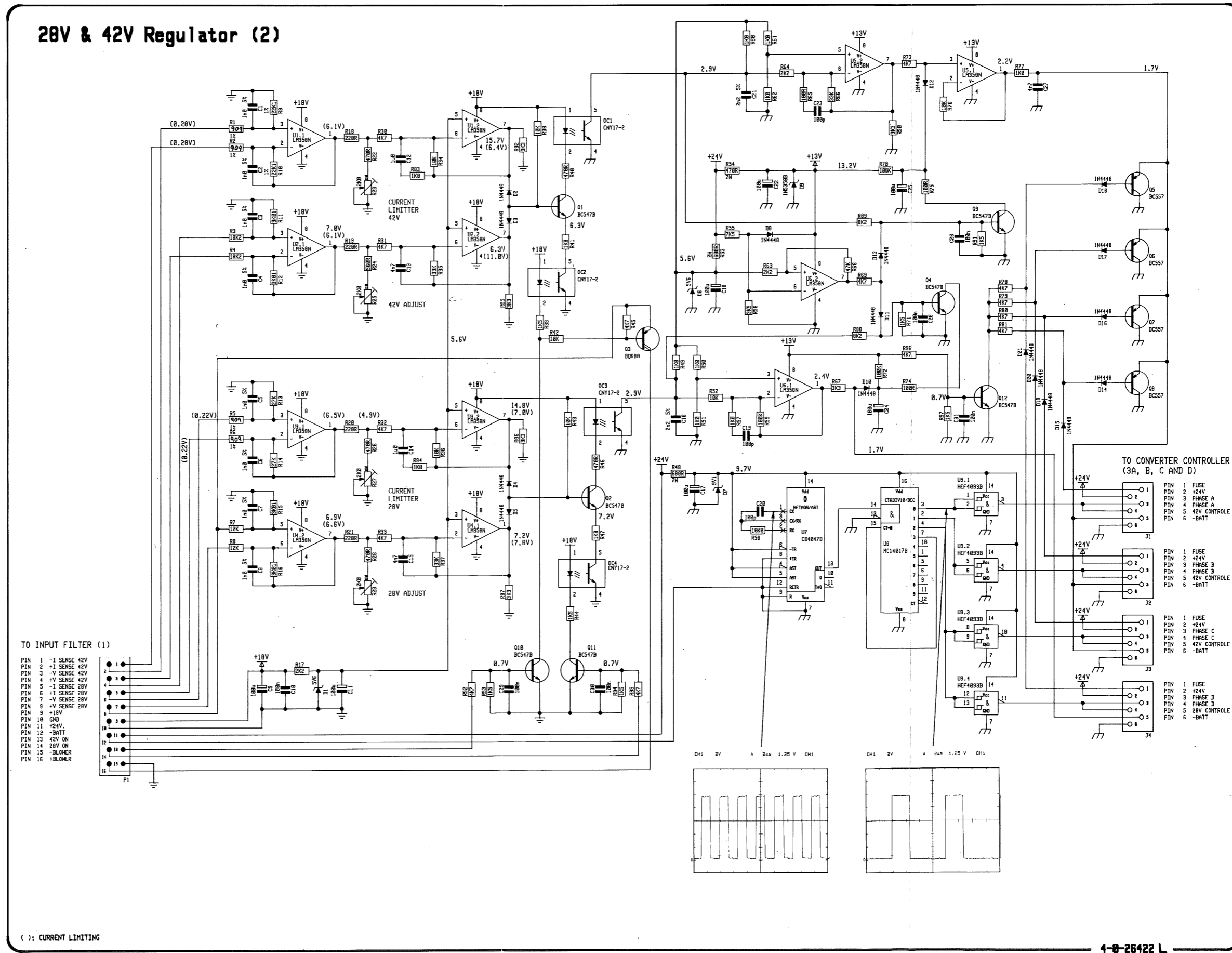

4-0-26422L

5.3 CONVERTER CONTROLLER (MODULE 3) PART NO. 626423

The internal 12V supply voltage is produced by the fixed 12 Volt regulator U3 and Q1. Q1 protects the voltage regulator against voltage spikes. The input voltage to U3 is limited to approx. 15V DC. C6, C3 and C7 are decoupling capacitors.

The 5V reference voltage of U2 is used as an internal 5V supply voltage.

The 5 Volt clock signal from the regulator module is shaped by the first NAND Schmitt trigger U1,2 and a well-defined pulse is produced by the one-shot formed by NAND-gates U1,1 and U1,3 and C1, D2 and R1. This pulse is used for two purposes. The first purpose is to make a saw tooth signal by D3, R3 and C5. This voltage signal is converted to a current signal by Q3 and R12 and used for slope compensation to ensure loop stability. The other purpose for the pulse is to override the internal clock of PWM regulator U2 via U1,4 and R8 and Q2.

The control voltage from the regulator module is sensed by the internal control voltage amplifier in U2. This amplifier is connected as a common mode amplifier (R2, C2, R7, R13, C10 and R11) to reduce noise sensitivity.

The current signal from the output transistors on the converter module is connected to the current sense amplifier inside U2. C8 is a noise decoupling capacitor.

The first output transistor pair is turned on by the clock pulse and the current running through it starts to increase. The current is sensed and the amplified current signal is then compared with the control voltage by U2. When the current signal is higher than the control voltage, the transistors are turned off. During the next clock period the other output transistor pair is turned on/off in the same way. The output current is controlled by the control voltage. The peak output current is limited by limiting the output voltage of the control voltage amplifier. The limit is determined by voltage of pin 1 of U2. This voltage is controlled by R4 and R5. C5 is a soft start capacitor.

If the voltage on the shut down terminal pin 16 on U2 is higher than 350 mV the output transistors are instantaneously turned off. This feature is used as a shut down in case of an overvoltage on the 24V supply voltage. The voltage is divided by R9, D4 and R10.

The shut down terminal is also connected to an overvoltage protection circuit for the output voltage on the converter module.

To reset the shut down function, it is necessary to switch off the relay R1 on the filter module by switching off the 28V ON signal.

The two output signals from U2 are passed on to the converter module as gate signals.

COMPONENT LOCATION CONVERTER CONTROLLER MODULE 3

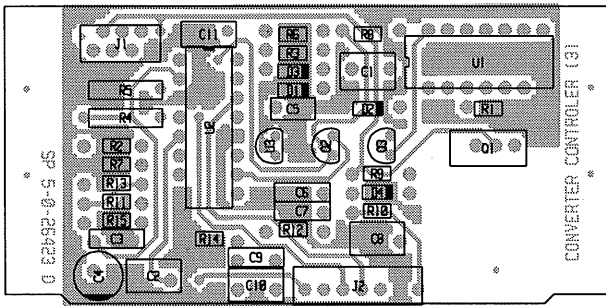

View from component side with upper side tracks.

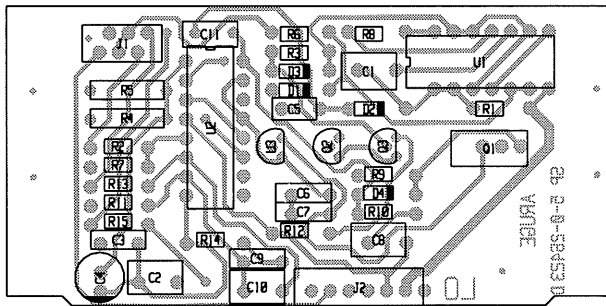

View from component side with lower side tracks.
PCB rev. 26423D

5-0-26423C / 4-6-26423C

CONVERTER CONTROLLER MODULE 3

Converter Controller (3)

TO 28V & 42V
REGULATOR (2)

- PIN 1 FUSE
- PIN 2 +24V
- PIN 3 PHASE
- PIN 4 PHASE
- PIN 5 CONTROLE VOLTAGE
- PIN 6 -BATT

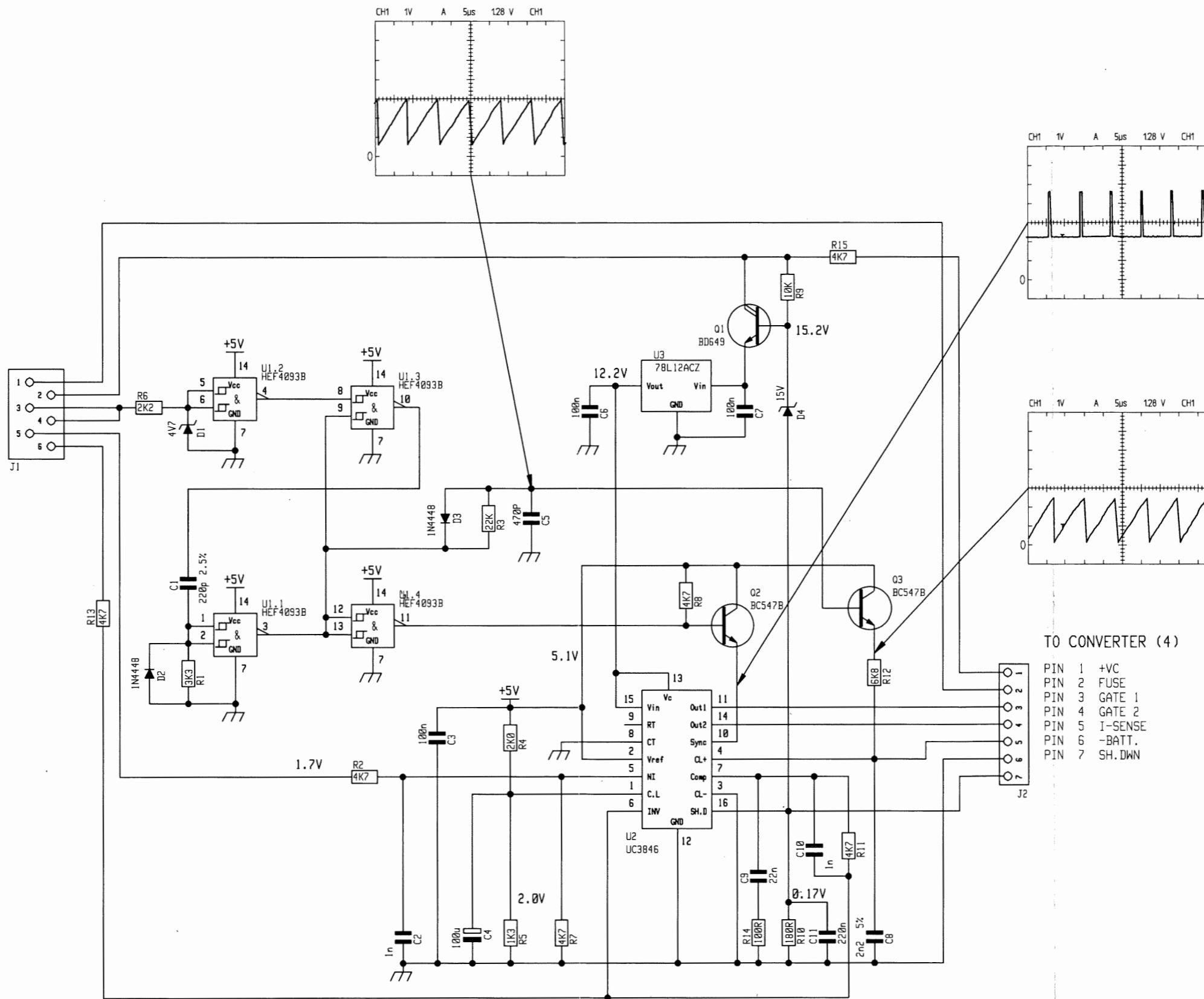

TO CONVERTER (4)

- PIN 1 +VC
- PIN 2 FUSE
- PIN 3 GATE 1
- PIN 4 GATE 2
- PIN 5 I-SENSE
- PIN 6 -BATT.
- PIN 7 SH. DWN

5.4 CONVERTER (MODULE 4)**PART NO. 626424 FOR 42V CONVERTER****PART NO. 726424 FOR 28V CONVERTER****NOTICE:**

For the converter module used as **42V converter**, D9 must be removed from the module, and if the output voltage exceeds approx. 53V, OC1 conducts and sends a voltage signal to the converter controller module, which immediately shuts down the converter.

For the converter module used as **28V converter**, D9 must be placed in the module, which means that the trigger level is approx. 35V.

The gate signals from the converter controller module is connected to the two pairs of output transistors Q1 + Q2 and Q3 + Q4. The diodes D1 and D2 protect the gates against voltage spikes and the resistors R1 and R2 keep the output transistors off, if the connection with converter controller module is missing. The resistors R3, R4, R5 and R6 protect against oscillation between the two transistors working as a pair. R8, C3 and R14, C5 remove oscillations caused by leakage inductance of the output transformer. The resistors R9 to R12 are used as current sense resistors. The signal is connected to the converter controller module via R7.

This resistor forms a lowpass filter together with capacitor C8 on the converter controller module.

A fuse control signal is connected via the converter controller module to the regulator module.

C1 and C2 are the energy reservoir.

The transformer TR1 transforms the pulse width regulated output signal to a higher voltage.

The diodes D3 to D6 form a full wave rectifier and the rectified current is used for charging the inductor L1 during the on period of the output transistors. During the off period, the diodes short-circuit the secondary of the transformer so the current running in L1 is able to continue.

The combination of C4 and R13 remove oscillations caused by the leakage inductance and the diode capacitances.

The capacitor C6 reduces the high frequency ripple.

In case of reverse polarity of the supply voltage the internal reverse diodes of the MOSFET's will blow the fuse F1.

The output of the converter module is connected to the input filter module.

The supply voltage to the converter module comes from the input filter module.

The optocoupler OC1 in conjunction with the diodes D7 to D9 forms an overvoltage protection circuit for the output voltage in case of a failure in the voltage regulation loop.

COMPONENT LOCATION CONVERTER MODULE 4

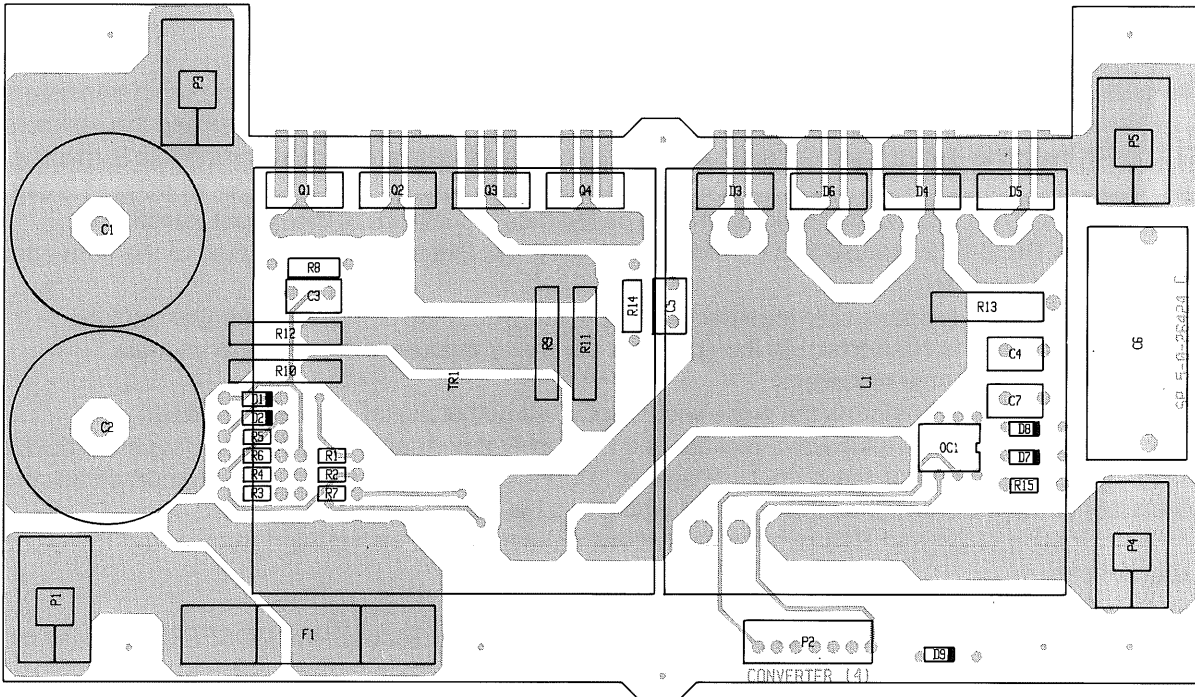

View from component side with upper side tracks.

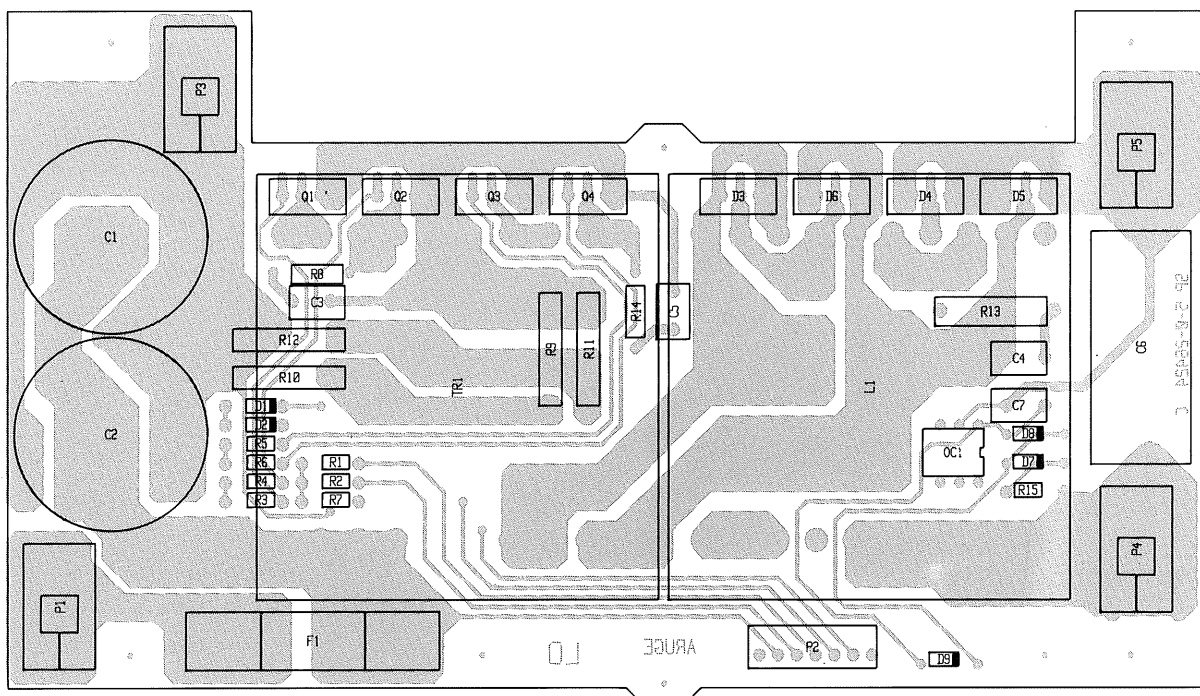

View from component side with lower side tracks.

CONVERTER MODULE 4

Converter (4)

FROM INPUT FILTER (1)

+BATT.

TO CONVERTER CONTROLLER (3)

- PIN 1 +Vc
- PIN 2 FUSE
- PIN 3 GATE 1
- PIN 4 GATE 2
- PIN 5 I-SENSE
- PIN 6 -BATT.
- PIN 7 SH. DWN

FROM INPUT FILTER (1)

-BATT.

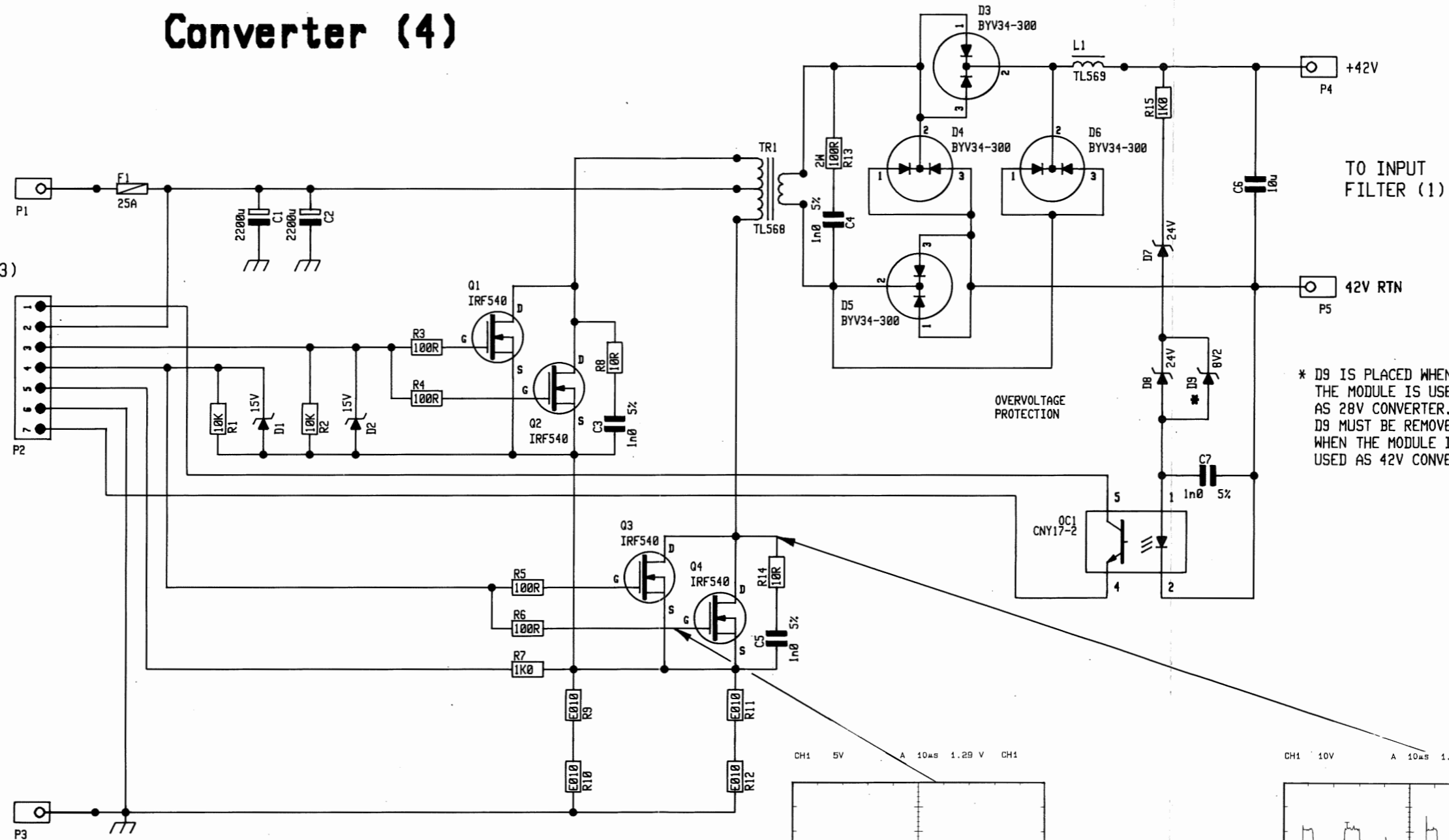

* D9 IS PLACED WHEN THE MODULE IS USED AS 28V CONVERTER. D9 MUST BE REMOVED WHEN THE MODULE IS USED AS 42V CONVERTER.

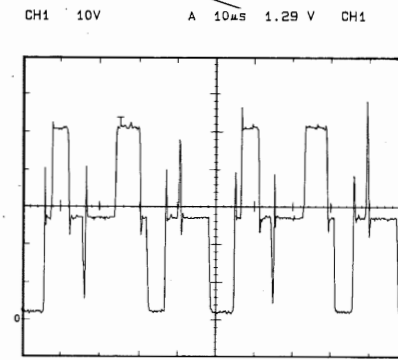
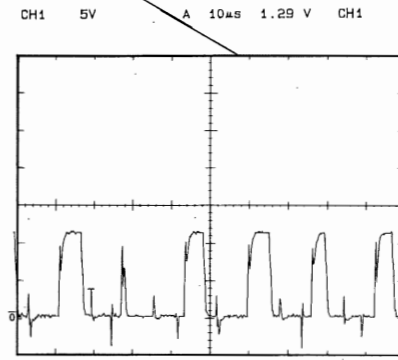

4-0-26424C

4-0-26424C

CONTENTS

6 PARTS LISTS

6-1

6 PARTS LISTS

P.S.UNIT, DC, 600W, N2170		HF SSB PROGRAMME	ECI A/S	0-0-26420	726420
POSITION	DESCRIPTION		MANUFACTOR	TYPE	PART NO.
VARIOUS	INPUT CABLE N2170/600W	N2170/600W	ECI A/S	0-0-26868	526868
VARIOUS	OUTPUT CABLE N2170		ECI A/S	0-0-27008	527008
VARIOUS	THERMOSTAT CABLE N2170		ECI A/S	0-0-27009	527009
VARIOUS	BLOWER CABLE N2170		ECI A/S	0-0-27010	527010
VARIOUS	INTERCONNECTION CABLE	6 POLES L=650mm	ECI A/S	3-0-27013A	527013
VARIOUS	INTERCONNECTION CABLE	6 POLES L=500mm	ECI A/S	3-0-27014B	527014
VARIOUS	INTERCONNECTION CABLE	6 POLES L=420mm	ECI A/S	3-0-27015C	527015
VARIOUS	INTERCONNECTION CABLE	6 POLES L=370mm	ECI A/S	3-0-27016B	527016
BL1-1	FAN 24VDC	119x119x38mm	PAPST	4124 KX	60.100
VARIOUS	SPARE FUSES FOR N2170		ECI A/S	0-0-27007	727007
-1	INPUT FILTER MODULE 1	N2170	ECI A/S	5-0-26421A / 4-0-26421C	626421
-2	28V & 42V REGULATOR MODUL	N2170	ECI A/S	5-0-26422B / 4-0-26422L	626422
-3a	CONVERTER CONTROLLER	MODULE (3) N2170	ECI A/S	5-0-26423D / 4-0-26423G	626423
-3b	CONVERTER CONTROLLER	MODULE (3) N2170	ECI A/S	5-0-26423D / 4-0-26423G	626423
-3c	CONVERTER CONTROLLER	MODULE (3) N2170	ECI A/S	5-0-26423D / 4-0-26423G	626423
-3d	CONVERTER CONTROLLER	MODULE (3) N2170	ECI A/S	5-0-26423D / 4-0-26423G	626423
-4a	CONVERTER MODULE 4	N2170	ECI A/S	5-0-26424C / 4-0-26424C	626424
-4b	CONVERTER MODULE 4	N2170	ECI A/S	5-0-26424C / 4-0-26424C	626424
-4c	CONVERTER MODULE 4	N2170	ECI A/S	5-0-26424C / 4-0-26424C	626424
-4d	CONVERTER MODULE 4d 28V	N2170	ECI A/S A/S	0-0-26424	726424
D2-1	DIODE POW.RECT.35A/100VDC	1N1184R/BYX52-300R	INT.RECTIFIER	1N1184R INCL.HARDWARE (1N1185R,-86R,---,-90R)	25.165
F2-1	FUSE	50A 11x41mm	BOSCH	1 191 017 005 DIN 72 581 - B 50	45.702
INPUT FILTER MODULE 1		N2170	ECI A/S	5-0-26421A / 4-0-26421C	626421
POSITION	DESCRIPTION		MANUFACTOR	TYPE	PART NO.
BL1-1	FAN 24VDC	119x119x38mm	PAPST	4124 KX	60.100
C1-1	CAPACITOR ELECTROLYTIC	2200uF -20/+50% 50VDC	PHILIPS	2222 021 18222	14.725
C2-1	CAPACITOR ELECTROLYTIC	2200uF -20/+50% 50VDC	PHILIPS	2222 021 18222	14.725
C3-1	CAPACITOR ELECTROLYTIC	2200uF -20/+50% 50VDC	PHILIPS	2222 021 18222	14.725
C4-1	CAPACITOR ELECTROLYTIC	2200uF -20/+50% 50VDC	PHILIPS	2222 021 18222	14.725
C5-1	CAPACITOR ELECTROLYTIC	2200uF -20/+50% 50VDC	PHILIPS	2222 021 18222	14.725
C6-1	CAPACITOR MKT	10uF 10% 63VDC	ERO	MKT 1822-610/06 5	11.086
C7-1	CAPACITOR MKT	10uF 10% 63VDC	ERO	MKT 1822-610/06 5	11.086
C8-1	CAPACITOR MKT	10uF 10% 63VDC	ERO	MKT 1822-610/06 5	11.086
C9-1	CAPACITOR MKT	10uF 10% 63VDC	ERO	MKT 1822-610/06 5	11.086
C10-1	CAPACITOR MKT	10uF 10% 63VDC	ERO	MKT 1822-610/06 5	11.086
C11-1	CAPACITOR MKT	0.1uF 10% 63VDC	PHILIPS	2222 370 78104	11.136
D1-1	DIODE RECTIFIER	1N4002 100V/1A	THOMSON	1N4002 (03/04/05/06/07)	25.100
D2-1	DIODE POW.RECT.35A/100VDC	1N1184R/BYX52-300R	INT.RECTIFIER	1N1184R INCL.HARDWARE (1N1185R,-86R,---,-90R)	25.165
F1-1	FUSE 5x20mm	315mA 250V TIME LAG	WICKMANN	19 195 315mAT	45.502
F2-1	FUSE	50A 11x41mm	BOSCH	1 191 017 005 DIN 72 581 - B 50	45.702
P1-1	CONNECTION ELEMENT	FOR M5 SCREW	ECI A/S	1-0-25860	225860
P2-1	CONNECTION ELEMENT	FOR M5 SCREW	ECI A/S	1-0-25860	225860
P3-1	CONNECTION ELEMENT	FOR M5 SCREW	ECI A/S	1-0-25860	225860
P4-1	CONNECTION ELEMENT	FOR M5 SCREW	ECI A/S	1-0-25860	225860
P5-1	MULTI PLUG	2x8 POLES PCB VERSION	3M	3599-6002 / 7616-6002 JL	78.249
P6-1	CONNECTION ELEMENT	FOR M5 SCREW	ECI A/S	1-0-25860	225860
P7-1	CONNECTION ELEMENT	FOR M5 SCREW	ECI A/S	1-0-25860	225860
P8-1	PLUG	2 POLES	AMP	0-826375-2	78.102
P9-1	PLUG 2POLES		MOLEX	39-28-1023	78.215
P10-1	CONNECTION ELEMENT	FOR M5 SCREW	ECI A/S	1-0-25860	225860
P11-1	MULTIPLUG	2x6 POLES PCB VERSION	MOLEX	39-28-1123	78.221
P12-1	CONNECTION ELEMENT	FOR M5 SCREW	ECI A/S	1-0-25860	225860
P13-1	CONNECTION ELEMENT	FOR M5 SCREW	ECI A/S	1-0-25860	225860
Q1-1	TRANSISTOR AF	BC547B NPN TO-92	PHILIPS	BC547B	28.067
R1-1	RESISTOR	10 MILLI OHM 2W	MODULOHM	10U-J-MI-A-1	06.210
R2-1	RESISTOR	10 MILLI OHM 2W	MODULOHM	10U-J-MI-A-1	06.210
R3-1	RESISTOR	10 MILLI OHM 2W	MODULOHM	10U-J-MI-A-1	06.210

POSITION	DESCRIPTION		MANUFACTOR	TYPE	PART NO.
P4-1	RESISTOR	10 MILLI OHM 2W	MODULOHM	10U-J-MI-A-1	06.210
R5-1	RESISTOR	10 MILLI OHM 2W	MODULOHM	10U-J-MI-A-1	06.210
R6-1	RESISTOR	10 MILLI OHM 2W	MODULOHM	10U-J-MI-A-1	06.210
R7-1	RESISTOR	10 MILLI OHM 2W	MODULOHM	10U-J-MI-A-1	06.210
R8-1	RESISTOR MF	4k7 OHM 5% 0.33W	PHILIPS	2322 187 73472	02.488
R9-1	RESISTOR MF	4k7 OHM 5% 0.33W	PHILIPS	2322 187 73472	02.488
RE1-1	RELAY	24VDC 2SH. 2A	OMRON	G5V-2-24 VDC	21.327
TB1-1	THERMAL BREAKER	OFF: 90 centigrade	AIRPAX	67L090	44.075
TR1-1	CHOKE	TL434	B.B.ELEKTRONIK	6-0-24569D	400434
TR2-1	CHOKE	TL434	B.B.ELEKTRONIK	6-0-24569D	400434

28V & 42V REGULATOR MODUL	N2170	ECI A/S	5-0-26422B / 4-0-26422L	626422
---------------------------	-------	---------	-------------------------	--------

POSITION	DESCRIPTION		MANUFACTOR	TYPE	PART NO.
C1-2	CAPACITOR POLYPROPYLENE	1nF 5% 10VDC	ERO	KP 1830-210/01-4-GW	13.398
C2-2	CAPACITOR POLYPROPYLENE	1nF 5% 10VDC	ERO	KP 1830-210/01-4-GW	13.398
C3-2	CAPACITOR POLYPROPYLENE	1nF 5% 10VDC	ERO	KP 1830-210/01-4-GW	13.398
C4-2	CAPACITOR POLYPROPYLENE	1nF 5% 10VDC	ERO	KP 1830-210/01-4-GW	13.398
C5-2	CAPACITOR POLYPROPYLENE	1nF 5% 10VDC	ERO	KP 1830-210/01-4-GW	13.398
C6-2	CAPACITOR POLYPROPYLENE	1nF 5% 10VDC	ERO	KP 1830-210/01-4-GW	13.398
C7-2	CAPACITOR POLYPROPYLENE	1nF 5% 10VDC	ERO	KP 1830-210/01-4-GW	13.398
C8-2	CAPACITOR POLYPROPYLENE	1nF 5% 10VDC	ERO	KP 1830-210/01-4-GW	13.398
C9-2	CAPACITOR ELECTROLYTIC	100uF -10/+50% 25VDC	ERO	EKM 00 CC 310 E G5	14.610
C10-2	CAPACITOR MKT	0.1uF 10% 63VDC	PHILIPS	2222 370 78104	11.136
C11-2	CAPACITOR ELECTROLYTIC	100uF 20% 10VDC	ELNA	RJ3-10-V-101-M-T34	14.607
C12-2	CAPACITOR MKT	1uF 5% 63VDC	ERO	MKT 1826-510/06 4-G	11.190
C13-2	CAPACITOR MKT	4n7F 10% 63VDC	PHILIPS	2222 370 88472	11.374
C14-2	CAPACITOR MKT	1uF 5% 63VDC	ERO	MKT 1826-510/06 4-G	11.190
C15-2	CAPACITOR MKT	4n7F 10% 63VDC	PHILIPS	2222 370 88472	11.374
C16-2	CAPACITOR POLYPROPYLENE	2n2F 5% 100VDC	* ERO	KP 1830-222/01-4-GW	13.400
C17-2	CAPACITOR ELECTROLYTIC	100uF 20% 10VDC	ELNA	RJ3-10-V-101-M-T34	14.607
C18-2	CAPACITOR ELECTROLYTIC	100uF 20% 10VDC	ELNA	RJ3-10-V-101-M-T34	14.607
C19-2	CAPACITOR CERAMIC	100 PF 5% N150 50VDC	KCK	RT-HE80-SK PH 101 J	15.133
C20-2	CAPACITOR CERAMIC	100 PF 5% N150 50VDC	KCK	RT-HE80-SK PH 101 J	15.133
C21-2	CAPACITOR POLYPROPYLENE	2n2F 5% 100VDC	* ERO	KP 1830-222/01-4-GW	13.400
C22-2	CAPACITOR ELECTROLYTIC	100uF -20/+50% 63VDC	ELNA	RJ2-63-V-101-M-F	14.620
C23-2	CAPACITOR CERAMIC	100 PF 5% N150 50VDC	KCK	RT-HE80-SK PH 101 J	15.133
C24-2	CAPACITOR ELECTROLYTIC	100uF -10/+50% 25VDC	ERO	EKM 00 CC 310 E G5	14.610
C25-2	CAPACITOR ELECTROLYTIC	100uF -10/+50% 25VDC	ERO	EKM 00 CC 310 E G5	14.610
C26-2	CAPACITOR MKT	0.1uF 10% 63VDC	PHILIPS	2222 370 78104	11.136
C27-2	CAPACITOR MKT	4n7F 10% 63VDC	PHILIPS	2222 370 88472	11.374
C28-2	CAPACITOR MKT	100nF 5% 63VDC	PHILIPS	2222 370 79104	11.135
C29-2	CAPACITOR MKT	0.1uF 10% 63VDC	PHILIPS	2222 370 78104	11.136
C30-2	CAPACITOR MKT	0.1uF 10% 63VDC	PHILIPS	2222 370 78104	11.136
C31-2	CAPACITOR MKT	0.1uF 10% 63VDC	PHILIPS	2222 370 78104	11.136
D1-2	DIODE ZENER	5V6 5% 0.4W BZX79C5V6	PHILIPS	BZX79C5V6	26.530
D2-2	DIODE HIGH SPEED	1N4448	PHILIPS	1N4448	25.147
D3-2	DIODE HIGH SPEED	1N4448	PHILIPS	1N4448	25.147
D4-2	DIODE HIGH SPEED	1N4448	PHILIPS	1N4448	25.147
D5-2	DIODE HIGH SPEED	1N4448	PHILIPS	1N4448	25.147
D6-2	DIODE ZENER	5V6 5% 0.4W BZX79C5V6	PHILIPS	BZX79C5V6	26.530
D7-2	DIODE ZENER	9V1 5% 0.4W BZX79C9V1	PHILIPS	BZX79C9V1	26.546
D8-2	DIODE HIGH SPEED	1N4448	PHILIPS	1N4448	25.147
D9-2	DIODE ZENER	13V 5% 5W 1N5350B	MOTOROLA	1N5350B	26.966
D10-2	DIODE HIGH SPEED	1N4448	PHILIPS	1N4448	25.147
D11-2	DIODE HIGH SPEED	1N4448	PHILIPS	1N4448	25.147
D12-2	DIODE HIGH SPEED	1N4448	PHILIPS	1N4448	25.147
D13-2	DIODE HIGH SPEED	1N4448	PHILIPS	1N4448	25.147
D14-2	DIODE HIGH SPEED	1N4448	PHILIPS	1N4448	25.147
D15-2	DIODE HIGH SPEED	1N4448	PHILIPS	1N4448	25.147
D16-2	DIODE HIGH SPEED	1N4448	PHILIPS	1N4448	25.147
D17-2	DIODE HIGH SPEED	1N4448	PHILIPS	1N4448	25.147
D18-2	DIODE HIGH SPEED	1N4448	PHILIPS	1N4448	25.147
D19-2	DIODE HIGH SPEED	1N4448	PHILIPS	1N4448	25.147
D20-2	DIODE HIGH SPEED	1N4448	PHILIPS	1N4448	25.147
D21-2	DIODE HIGH SPEED	1N4448	PHILIPS	1N4448	25.147
J1-2	SOCKET	2x3 POLES	AMP	0-215079-6	78.192
J2-2	SOCKET	2x3 POLES	AMP	0-215079-6	78.192

POSITION	DESCRIPTION		MANUFACTURER	TYPE	PART NO.
J3-2	SOCKET	2x3 POLES	AMP	0-215079-6	78.192
J4-2	SOCKET	2x3 POLES	AMP	0-215079-6	78.192
OC1-2	OPTO COUPLER	CNY17-2	MOTOROLA	CNY17-2	32.530
OC2-2	OPTO COUPLER	CNY17-2	MOTOROLA	CNY17-2	32.530
OC3-2	OPTO COUPLER	CNY17-2	MOTOROLA	CNY17-2	32.530
OC4-2	OPTO COUPLER	CNY17-2	MOTOROLA	CNY17-2	32.530
P1-2	MULTI PLUG	2x8 POLES PCB VERSION	3M	3599-6002 / 7616-6002 JL	78.249
Q1-2	TRANSISTOR AF	BC547B NPN TO-92	PHILIPS	BC547B	28.067
Q2-2	TRANSISTOR AF	BC547B NPN TO-92	PHILIPS	BC547B	28.067
Q3-2	TRANSISTOR	BD680	PHILIPS*	BDX47	29.338
Q4-2	TRANSISTOR AF	BC547B NPN TO-92	PHILIPS	BC547B	28.067
Q5-2	TRANSISTOR	BC557	MOTOROLA*	BC557 A/B/C	28.087
Q6-2	TRANSISTOR	BC557	MOTOROLA*	BC557 A/B/C	28.087
Q7-2	TRANSISTOR	BC557	MOTOROLA*	BC557 A/B/C	28.087
Q8-2	TRANSISTOR	BC557	MOTOROLA*	BC557 A/B/C	28.087
Q9-2	TRANSISTOR AF	BC547B NPN TO-92	PHILIPS	BC547B	28.067
Q10-2	TRANSISTOR AF	BC547B NPN TO-92	PHILIPS	BC547B	28.067
Q11-2	TRANSISTOR AF	BC547B NPN TO-92	PHILIPS	BC547B	28.067
Q12-2	TRANSISTOR AF	BC547B NPN TO-92	PHILIPS	BC547B	28.067
R1-2	RESISTOR MF	909 OHM 1% 0.25W	PHILIPS	2322 157 19091	02.218
R2-2	RESISTOR MF	909 OHM 1% 0.25W	PHILIPS	2322 157 19091	02.218
R3-2	RESISTOR MF	18k2 OHM 1% 0.6W	PHILIPS	2322 156 11823	03.431
R4-2	RESISTOR MF	18k2 OHM 1% 0.6W	PHILIPS	2322 156 11823	03.431
R5-2	RESISTOR MF	909 OHM 1% 0.25W	PHILIPS	2322 157 19091	02.218
R6-2	RESISTOR MF	909 OHM 1% 0.25W	PHILIPS	2322 157 19091	02.218
R7-2	RESISTOR MF	12k OHM 5% 0.4W	PHILIPS	2322 181 53123	01.227
R8-2	RESISTOR MF	12k OHM 5% 0.4W	PHILIPS	2322 181 53123	01.227
R9-2	RESISTOR MF	22k1 OHM 1% 0.25W	PHILIPS	2322 157 12213	02.234
R10-2	RESISTOR MF	22k1 OHM 1% 0.25W	PHILIPS	2322 157 12213	02.234
R11-2	RESISTOR MF	3k01 OHM 1% 0.6W	PHILIPS	2322 156 13012	03.411
R12-2	RESISTOR MF	3k01 OHM 1% 0.6W	PHILIPS	2322 156 13012	03.411
R13-2	RESISTOR MF	27k OHM 5% 0.33W	PHILIPS	2322 187 73273	02.506
R14-2	RESISTOR MF	27k OHM 5% 0.33W	PHILIPS	2322 187 73273	02.506
R15-2	RESISTOR MF	3k01 OHM 1% 0.6W	PHILIPS	2322 156 13012	03.411
R16-2	RESISTOR MF	3k01 OHM 1% 0.6W	PHILIPS	2322 156 13012	03.411
R17-2	RESISTOR MF	2k2 OHM 5% 0.33W	PHILIPS	2322 187 73222	02.480
R18-2	RESISTOR MF	220 OHM 5% 0.33W	PHILIPS	2322 187 73221	02.456
R19-2	RESISTOR MF	220 OHM 5% 0.33W	PHILIPS	2322 187 73221	02.456
R20-2	RESISTOR MF	220 OHM 5% 0.33W	PHILIPS	2322 187 73221	02.456
R21-2	RESISTOR MF	220 OHM 5% 0.33W	PHILIPS	2322 187 73221	02.456
R22-2	RESISTOR MF	470 OHM 5% 0.33W	PHILIPS	2322 187 73471	02.464
R23-2	PRESET CERMET	2k0 OHM 5% 0.5W	BOURNS	3386P-1-202-11	07.887
R24-2	RESISTOR MF	560 OHM 5% 0.4W	PHILIPS	2322 181 53561	01.193
R25-2	PRESET CERMET	2k0 OHM 5% 0.5W	BOURNS	3386P-1-202-11	07.887
R26-2	RESISTOR MF	470 OHM 5% 0.33W	PHILIPS	2322 187 73471	02.464
R27-2	PRESET CERMET	2k0 OHM 5% 0.5W	BOURNS	3386P-1-202-11	07.887
R28-2	RESISTOR MF	470 OHM 5% 0.33W	PHILIPS	2322 187 73471	02.464
R29-2	PRESET CERMET	2k0 OHM 5% 0.5W	BOURNS	3386P-1-202-11	07.887
R30-2	RESISTOR MF	4k7 OHM 5% 0.33W	PHILIPS	2322 187 73472	02.488
R31-2	RESISTOR MF	4k7 OHM 5% 0.33W	PHILIPS	2322 187 73472	02.488
R32-2	RESISTOR MF	4k7 OHM 5% 0.33W	PHILIPS	2322 187 73472	02.488
R33-2	RESISTOR MF	4k7 OHM 5% 0.33W	PHILIPS	2322 187 73472	02.488
R34-2	RESISTOR MF	10k OHM 5% 0.33W	PHILIPS	2322 187 73103	02.496
R35-2	RESISTOR MF	33k OHM 5% 0.33W	PHILIPS	2322 187 73333	02.508
R36-2	RESISTOR MF	10k OHM 5% 0.33W	PHILIPS	2322 187 73103	02.496
R37-2	RESISTOR MF	33k OHM 5% 0.33W	PHILIPS	2322 187 73333	02.508
R38-2	RESISTOR MF	10k OHM 5% 0.33W	PHILIPS	2322 187 73103	02.496
R39-2	RESISTOR MF	1k5 OHM 5% 0.33W	PHILIPS	2322 187 73152	02.476
R40-2	RESISTOR MF	470 OHM 5% 0.33W	PHILIPS	2322 187 73471	02.464
R41-2	RESISTOR MF	1k8 OHM 5% 0.33W	PHILIPS	2322 187 73182	02.478
R42-2	RESISTOR MF	10k OHM 5% 0.33W	PHILIPS	2322 187 73103	02.496
R43-2	RESISTOR MF	10k OHM 5% 0.33W	PHILIPS	2322 187 73103	02.496
R44-2	RESISTOR MF	1k5 OHM 5% 0.33W	PHILIPS	2322 187 73152	02.476
R45-2	RESISTOR MF	4k7 OHM 5% 0.33W	PHILIPS	2322 187 73472	02.488
R46-2	RESISTOR MF	470 OHM 5% 0.33W	PHILIPS	2322 187 73471	02.464
R47-2	RESISTOR MF	1k8 OHM 5% 0.33W	PHILIPS	2322 187 73182	02.478
R48-2	RESISTOR PMF	680 OHM 5% 2W	PHILIPS	2322 194 13681	04.195

POSITION	DESCRIPTION		MANUFACTURER	TYPE	PART NO.
R49-2	RESISTOR MF	1k0 OHM 5% 0.33W	PHILIPS	2322 187 73102	02.472
R50-2	RESISTOR MF	1k0 OHM 5% 0.33W	PHILIPS	2322 187 73102	02.472
R51-2	RESISTOR MF	1k0 OHM 5% 0.33W	PHILIPS	2322 187 73102	02.472
R52-2	RESISTOR MF	10k OHM 5% 0.33W	PHILIPS	2322 187 73103	02.496
R53-2	RESISTOR PMF	680 OHM 5% 2W	PHILIPS	2322 194 13681	04.195
R54-2	RESISTOR PMF	470 OHM 5% 2W	PHILIPS	2322 194 13471	04.191
R55-2	RESISTOR MF	7k5 OHM 5% 0.33W	PHILIPS	2322 187 73752	02.493
R56-2	RESISTOR MF	3k9 OHM 5% 0.33W	PHILIPS	2322 187 73392	02.486
R57-2	RESISTOR MF	1k0 OHM 5% 0.33W	PHILIPS	2322 187 73102	02.472
R58-2	RESISTOR MF	10k0 OHM 1% 0.6W	PHILIPS	2322 156 11003	03.427
R59-2	RESISTOR MF	100k OHM 5% 0.33W	PHILIPS	2322 187 73104	02.520
R60-2	RESISTOR MF	1k0 OHM 5% 0.33W	PHILIPS	2322 187 73102	02.472
R61-2	RESISTOR MF	1k0 OHM 5% 0.33W	PHILIPS	2322 187 73102	02.472
R62-2	RESISTOR MF	1k0 OHM 5% 0.33W	PHILIPS	2322 187 73102	02.472
R63-2	RESISTOR MF	2k2 OHM 5% 0.33W	PHILIPS	2322 187 73222	02.480
R64-2	RESISTOR MF	2k2 OHM 5% 0.33W	PHILIPS	2322 187 73222	02.480
R65-2	RESISTOR MF	100 OHM 5% 0.33W	PHILIPS	2322 187 73101	02.448
R66-2	RESISTOR MF	33k OHM 5% 0.33W	PHILIPS	2322 187 73333	02.508
R67-2	RESISTOR MF	3k3 OHM 5% 0.33W	PHILIPS	2322 187 73332	02.484
R68-2	RESISTOR MF	47k OHM 5% 0.33W	PHILIPS	2322 187 73473	02.512
R69-2	RESISTOR MF	4k7 OHM 5% 0.33W	PHILIPS	2322 187 73472	02.488
R70-2	RESISTOR MF	100k OHM 5% 0.33W	PHILIPS	2322 187 73104	02.520
R71-2	RESISTOR MF	1k5 OHM 5% 0.33W	PHILIPS	2322 187 73152	02.476
R72-2	RESISTOR MF	100k OHM 5% 0.33W	PHILIPS	2322 187 73104	02.520
R73-2	RESISTOR MF	4k7 OHM 5% 0.33W	PHILIPS	2322 187 73472	02.488
R74-2	RESISTOR MF	100 OHM 5% 0.33W	PHILIPS	2322 187 73101	02.448
R75-2	RESISTOR MF	100 OHM 5% 0.33W	PHILIPS	2322 187 73101	02.448
R76-2	RESISTOR MF	10k OHM 5% 0.33W	PHILIPS	2322 187 73103	02.496
R77-2	RESISTOR MF	1k0 OHM 5% 0.33W	PHILIPS	2322 187 73102	02.472
R78-2	RESISTOR MF	4k7 OHM 5% 0.33W	PHILIPS	2322 187 73472	02.488
R79-2	RESISTOR MF	4k7 OHM 5% 0.33W	PHILIPS	2322 187 73472	02.488
R80-2	RESISTOR MF	4k7 OHM 5% 0.33W	PHILIPS	2322 187 73472	02.488
R81-2	RESISTOR MF	4k7 OHM 5% 0.33W	PHILIPS	2322 187 73472	02.488
R82-2	RESISTOR MF	3k3 OHM 5% 0.33W	PHILIPS	2322 187 73332	02.484
R83-2	RESISTOR MF	1k0 OHM 5% 0.33W	PHILIPS	2322 187 73102	02.472
R84-2	RESISTOR MF	1k0 OHM 5% 0.33W	PHILIPS	2322 187 73102	02.472
R85-2	RESISTOR MF	3k3 OHM 5% 0.33W	PHILIPS	2322 187 73332	02.484
R86-2	RESISTOR MF	3k3 OHM 5% 0.33W	PHILIPS	2322 187 73332	02.484
R87-2	RESISTOR MF	3k3 OHM 5% 0.33W	PHILIPS	2322 187 73332	02.484
R88-2	RESISTOR MF	8k2 OHM 5% 0.33W	PHILIPS	2322 187 73822	02.494
R89-2	RESISTOR MF	8k2 OHM 5% 0.33W	PHILIPS	2322 187 73822	02.494
R90-2	RESISTOR MF	3k3 OHM 5% 0.33W	PHILIPS	2322 187 73332	02.484
R91-2	RESISTOR MF	1k5 OHM 5% 0.33W	PHILIPS	2322 187 73152	02.476
R92-2	RESISTOR MF	4k7 OHM 5% 0.33W	PHILIPS	2322 187 73472	02.488
R93-2	RESISTOR MF	1k5 OHM 5% 0.33W	PHILIPS	2322 187 73152	02.476
R94-2	RESISTOR MF	1k5 OHM 5% 0.33W	PHILIPS	2322 187 73152	02.476
R95-2	RESISTOR MF	4k7 OHM 5% 0.33W	PHILIPS	2322 187 73472	02.488
R96-2	RESISTOR MF	4k7 OHM 5% 0.33W	PHILIPS	2322 187 73472	02.488
R97-2	RESISTOR MF	1k5 OHM 5% 0.33W	PHILIPS	2322 187 73152	02.476
U1-2	DUAL OP AMP	LM358N	TEXAS	LM358P	31.100
U2-2	DUAL OP AMP	LM358N	TEXAS	LM358P	31.100
U3-2	DUAL OP AMP	LM358N	TEXAS	LM358P	31.100
U4-2	DUAL OP AMP	LM358N	TEXAS	LM358P	31.100
U5-2	DUAL OP AMP	LM358N	TEXAS	LM358P	31.100
U6-2	DUAL OP AMP	LM358N	TEXAS	LM358P	31.100
U7-2	CD4047B			CD4047B	33.165
U8-2	INTEGRATED CIRCUIT	MC14017BCP	PHILIPS*	HEF4017BP	33.085
U9-2	QUAD 2-INP.NAND SCHM.TRI	MC14093BCP	MOTOROLA*	MC14093BCP	33.300

CONVERTER CONTROLLER MODULE (3) N2170 ECI A/S 5-0-26423D / 4-0-26423G 626423

POSITION	DESCRIPTION		MANUFACTURER	TYPE	PART NO.
C11	CAPACITOR MKT	220nF 20% 63VDC	ERO	MKT 1826-422/06 6-G	11.183
C1-3	CAPACITOR POLYPROPYLENE	220pF 2.5% 100VDC	* ERO	KP 1830-122/01-3-GW	13.394
C2-3	CAPACITOR POLYPROPYLENE	1nF 5% 10VDC	ERO	KP 1830-210/01-4-GW	13.398
C3-3	CAPACITOR MKT	100nF 5% 63VDC	PHILIPS	2222 370 79104	11.135
C4-3	CAPACITOR ELECTROLYTIC	100uF 20% 10VDC	ELNA	RJ3-10-V-101-M-T34	14.607
C5-3	CAPACITOR CERAMIC	470pF 10% 500VDC	KCK	RT-HM60 SK YB 471 K	16.095

POSITION	DESCRIPTION		MANUFACTOR	TYPE	PART NO.
C6-3	CAPACITOR MKT	100nF 5% 63VDC	PHILIPS	2222 370 79104	11.135
C7-3	CAPACITOR MKT	100nF 5% 63VDC	PHILIPS	2222 370 79104	11.135
C8-3	CAPACITOR POLYPROPYLENE	2n2F 5% 100VDC	* ERO	KP 1830-222/01-4-GW	13.400
C9-3	CAPACITOR MKT	22nF 10% 100VDC	PHILIPS	2222 370 88223	11.175
C10-3	CAPACITOR POLYPROPYLENE	1nF 5% 10VDC	ERO	KP 1830-210/01-4-GW	13.398
D1-3	DIODE ZENER	4.7V 5% 0.4W BZX79C4V7	PHILIPS	BZX79C4V7	26.524
D2-3	DIODE HIGH SPEED	1N4448	PHILIPS	1N4448	25.147
D3-3	DIODE HIGH SPEED	1N4448	PHILIPS	1N4448	25.147
D4-3	DIODE ZENER	15V 5% 0.4W BZX79C15	PHILIPS	BZX79C15	26.561
J1-3	SOCKET	2x3 POLES	AMP	0-215079-6	78.192
J2-3	MI MATCH 7 POLE, 90 DEG.		AMP	0-0164711-7	78.035
R1-3	RESISTOR MF	3k3 OHM 5% 0.33W	PHILIPS	2322 187 73332	02.484
R2-3	RESISTOR MF	4k7 OHM 5% 0.33W	PHILIPS	2322 187 73472	02.488
R3-3	RESISTOR MF	22k OHM 5% 0.33W	PHILIPS	2322 187 73223	02.504
R4-3	RESISTOR MF	2k0 OHM 1% 0.6W	* PHILIPS	2322 156 12002	03.403
R5-3	RESISTOR MF	1k3 OHM 1% 0.6W	PHILIPS	2322 156 11302	03.402
R6-3	RESISTOR MF	2k2 OHM 5% 0.33W	PHILIPS	2322 187 73222	02.480
R7-3	RESISTOR MF	4k7 OHM 5% 0.33W	PHILIPS	2322 187 73472	02.488
R8-3	RESISTOR MF	4k7 OHM 5% 0.33W	PHILIPS	2322 187 73472	02.488
R9-3	RESISTOR MF	10k OHM 5% 0.33W	PHILIPS	2322 187 73103	02.496
R10-3	RESISTOR MF	180 OHM 5% 0.33W	PHILIPS	2322 187 73181	02.454
R11-3	RESISTOR MF	4k7 OHM 5% 0.33W	PHILIPS	2322 187 73472	02.488
R12-3	RESISTOR MF	6k8 OHM 5% 0.33W	PHILIPS	2322 187 73682	02.492
R13-3	RESISTOR MF	4k7 OHM 5% 0.33W	PHILIPS	2322 187 73472	02.488
R14-3	RESISTOR MF	100 OHM 5% 0.33W	PHILIPS	2322 187 73101	02.448
R15-3	RESISTOR MF	4k7 OHM 5% 0.33W	PHILIPS	2322 187 73472	02.488
Q1-3	TRANS. AF POWER NPN	DARL. BD649/901 BDX53C	MOTOROLA	BDX53C	29.085
Q2-3	TRANSISTOR AF	BC547B NPN TO-92	PHILIPS	BC547B	28.067
Q3-3	TRANSISTOR AF	BC547B NPN TO-92	PHILIPS	BC547B	28.067
U1-3	QUAD 2-INP.NAND SCHM.TRI	MC14093BCP	MOTOROLA*	MC14093BCP	33.300
U2-3	CURRENT MODE PWM CONTROL.	UC3846	UNITRODE	UC3846	31.486
U3-3	VOLTAGE REGULATOR	12V 5% 0.1A 78L12AC	MOTOROLA	MC78L12ACP	31.139

CONVERTER MODULE 4**N2170****ECI A/S****5-0-26424C / 4-0-26424C****626424**

POSITION	DESCRIPTION		MANUFACTOR	TYPE	PART NO.
C1-4	CAPACITOR ELECTROLYTIC	2200uF -20/+50% 63VDC	PHILIPS	2222 021 48222	14.733
C2-4	CAPACITOR ELECTROLYTIC	2200uF -20/+50% 63VDC	PHILIPS	2222 021 48222	14.733
C3-4	CAPACITOR POLYPROPYLENE	1nF 5% 10VDC	ERO	KP 1830-210/01-4-GW	13.398
C4-4	CAPACITOR POLYPROPYLENE	1nF 5% 10VDC	ERO	KP 1830-210/01-4-GW	13.398
C5-4	CAPACITOR POLYPROPYLENE	1nF 5% 10VDC	ERO	KP 1830-210/01-4-GW	13.398
C6-4	CAPACITOR MKT	10uF 10% 63VDC	ERO	MKT 1822-610/06 5	11.086
C7-4	CAPACITOR POLYPROPYLENE	1nF 5% 10VDC	ERO	KP 1830-210/01-4-GW	13.398
D1-4	DIODE ZENER	15V 5% 0.4W BZX79C15	PHILIPS	BZX79C15	26.561
D2-4	DIODE ZENER	15V 5% 0.4W BZX79C15	PHILIPS	BZX79C15	26.561
D3-4	DIODE DUAL 2x10A/300VDC	TO-220 BYV34-300	PHILIPS	BYV34-300 (-400-500)	27.158
D4-4	DIODE DUAL 2x10A/300VDC	TO-220 BYV34-300	PHILIPS	BYV34-300 (-400-500)	27.158
D5-4	DIODE DUAL 2x10A/300VDC	TO-220 BYV34-300	PHILIPS	BYV34-300 (-400-500)	27.158
D6-4	DIODE DUAL 2x10A/300VDC	TO-220 BYV34-300	PHILIPS	BYV34-300 (-400-500)	27.158
D7-4	DIODE ZENER	24V 5% 0.4W BZX79C24	PHILIPS	BZX79C24	26.572
D8-4	DIODE ZENER	24V 5% 0.4W BZX79C24	PHILIPS	BZX79C24	26.572
D9-4	DIODE ZENER	8V2 5% 0.4W BZX79C8V2	PHILIPS	BZX79C8V2	26.542
F1-4	FUSE 25A 6.3x32mm	MEDIUM TIME LAG	LITTEL FUSE	314025	45.632
L1-4	SMPS CHOKE FOR N2170	TL569	ECI A/S	6-0-27005	400569
OC1-4	OPTO COUPLER	CNY17-2	MOTOROLA	CNY17-2	32.530
P1-4	CONNECTION ELEMENT	FOR M5 SCREW	ECI A/S	1-0-25860	225860
P2-4	MI MATCH 7 POLE, MALE		AMP	0-0164713-7	78.040
P3-4	CONNECTION ELEMENT	FOR M5 SCREW	ECI A/S	1-0-25860	225860
P4-4	CONNECTION ELEMENT	FOR M5 SCREW	ECI A/S	1-0-25860	225860
P5-4	CONNECTION ELEMENT	FOR M5 SCREW	ECI A/S	1-0-25860	225860
Q1-4	TRANS.POW.MOSFET N-CHANN.	100V/27A/85mOHM IRF540	MOTOROLA	IRF540	29.402
Q2-4	TRANS.POW.MOSFET N-CHANN.	100V/27A/85mOHM IRF540	MOTOROLA	IRF540	29.402
Q3-4	TRANS.POW.MOSFET N-CHANN.	100V/27A/85mOHM IRF540	MOTOROLA	IRF540	29.402
Q4-4	TRANS.POW.MOSFET N-CHANN.	100V/27A/85mOHM IRF540	MOTOROLA	IRF540	29.402
R1-4	RESISTOR MF	10k OHM 5% 0.33W	PHILIPS	2322 187 73103	02.496
R2-4	RESISTOR MF	10k OHM 5% 0.33W	PHILIPS	2322 187 73103	02.496
R3-4	RESISTOR MF	100 OHM 5% 0.33W	PHILIPS	2322 187 73101	02.448
R4-4	RESISTOR MF	100 OHM 5% 0.33W	PHILIPS	2322 187 73101	02.448

POSITION	DESCRIPTION		MANUFACTOR	TYPE	PART NO.
R5-4	RESISTOR MF	100 OHM 5% 0.33W	PHILIPS	2322 187 73101	02.448
R6-4	RESISTOR MF	100 OHM 5% 0.33W	PHILIPS	2322 187 73101	02.448
R7-4	RESISTOR MF	1k0 OHM 5% 0.33W	PHILIPS	2322 187 73102	02.472
R8-4	RESISTOR MF	10 OHM 5% 0.4W	PHILIPS	2322 181 53109	01.150
R9-4	RESISTOR	10 MILLI OHM 2W	MODULOHM	10U-J-MI-A-1	06.210
R10-4	RESISTOR	10 MILLI OHM 2W	MODULOHM	10U-J-MI-A-1	06.210
R11-4	RESISTOR	10 MILLI OHM 2W	MODULOHM	10U-J-MI-A-1	06.210
R12-4	RESISTOR	10 MILLI OHM 2W	MODULOHM	10U-J-MI-A-1	06.210
R13-4	RESISTOR PMF	100 OHM 5% 2W	PHILIPS	2322 194 13101	04.175
R14-4	RESISTOR MF	10 OHM 5% 0.4W	PHILIPS	2322 181 53109	01.150
R15-4	RESISTOR MF	1k0 OHM 5% 0.33W	PHILIPS	2322 187 73102	02.472
TR1-4	SMPS TRAF0 FOR N2170	TL568	ECI A/S	6-0-27004A	400568

CONVERTER MODULE 4d 28V	N2170	ECI A/S A/S	0-0-26424	726424
--------------------------------	--------------	--------------------	------------------	---------------

POSITION	DESCRIPTION		MANUFACTOR	TYPE	PART NO.
-4d	CONVERTER MODULE 4	N2170	ECI A/S	5-0-26424C / 4-0-26424C	626424
D9-4	DIODE ZENER	8V2 5% 0.4W BZX79C8V2	PHILIPS	BZX79C8V2	26.542

TECHNICAL MANUAL FOR POWER SUPPLY UNIT 220V AC 600W
 (N2171) PART NO. 726430

CONTENTS

1	GENERAL INFORMATION	
1.1	INTRODUCTION	1-1
1.2	PRINCIPLE OF OPERATION	1-1
2	INSTALLATION	
2.1	ELECTRICAL CONNECTION AND ASSEMBLING	2-1
3	SERVICE	
3.1	MAINTENANCE	3-1
3.2	RECOMMENDED TEST EQUIPMENT	3-1
3.3	TROUBLE SHOOTING	3-1
3.4	PERFORMANCE CHECK	3-1
3.5	NECESSARY CHECK AND ADJUSTMENT AFTER REPAIR	3-2
4	MECHANICAL DESCRIPTION	
4.1	MECHANICAL ASSEMBLING / DISASSEMBLING AND UNITS LOCATION	4-1
5	CIRCUIT DESCRIPTION AND SCHEMATIC DIAGRAMS	
5.1	28V REGULATOR (MODULE 1) PART NO. 626431	5-1
5.2	42V REGULATOR (MODULE 2) PART NO. 626432	5-5
5.3	MAIN SCHEMATIC DIAGRAMME N2171	5-11
6	PARTS LISTS	

CONTENTS

1	GENERAL INFORMATION	1-1
1.1	INTRODUCTION	1-1
1.2	PRINCIPLE OF OPERATION	1-1

1 GENERAL INFORMATION

1.1 INTRODUCTION

This section gives you all necessary information to make service of this unit down to component level.

1.2 PRINCIPLE OF OPERATION

The power supply N2171 is an insulated thyristor rectifier with two thyristors placed on the secondary side of a main transformer to minimize the interference into the mains.

The mains voltage is transformed down to two secondary voltages. One for producing a 28V DC voltage and the other for producing a 42V DC voltage. The 28V output voltage is stabilized by an ordinary series regulator module with MOSFET's.

The 42V output is stabilized by a regulator module which contains a thyristor regulated rectifier bridge. This module measures the output voltage and controls the turn-on time for the thyristors. The output from the rectifier is incomplete sine waves.

These pulses are then filtered by an output LC-filter to give a DC voltage.

The 42V module has a current limiter which reduces the output voltage if the current is too high. Both the 28V and the 42V outputs can be switched on and off separately and is controlled by a microprocessor.

To cool the power supply, a blower is switched on simultaneously with both output voltages. If the temperature gets too high when only the 28V is switched on, a thermal breaker turns on the blower.

In case of blower failure another thermal breaker turns off the 28V until the temperature is low again.

BLOCKDIAGRAMME FOR N2171

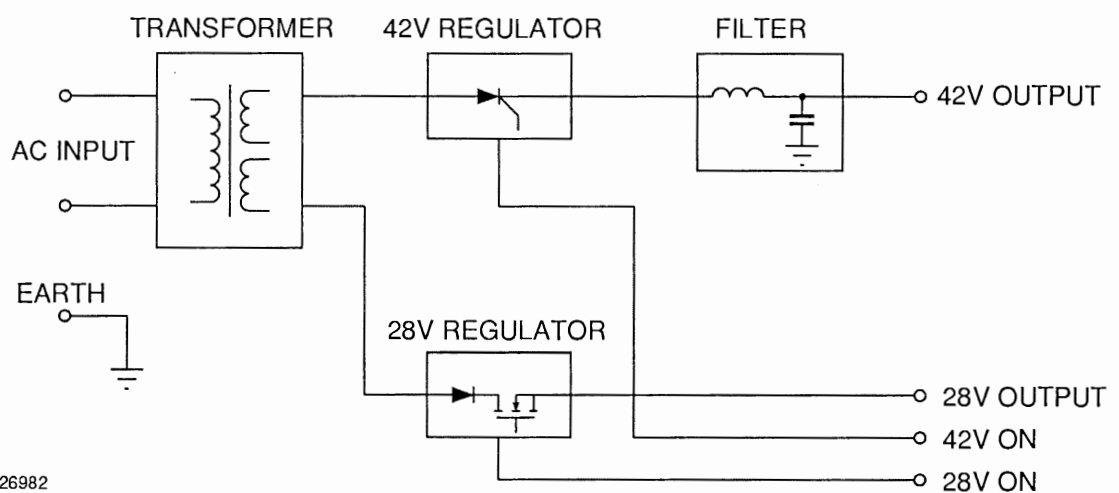

26982

CONTENTS

2	INSTALLATION	2-1
2.1	ELECTRICAL CONNECTION AND ASSEMBLING	2-1

2 INSTALLATION

2.1 ELECTRICAL CONNECTION AND ASSEMBLING

CONNECTION TO N2171 600W

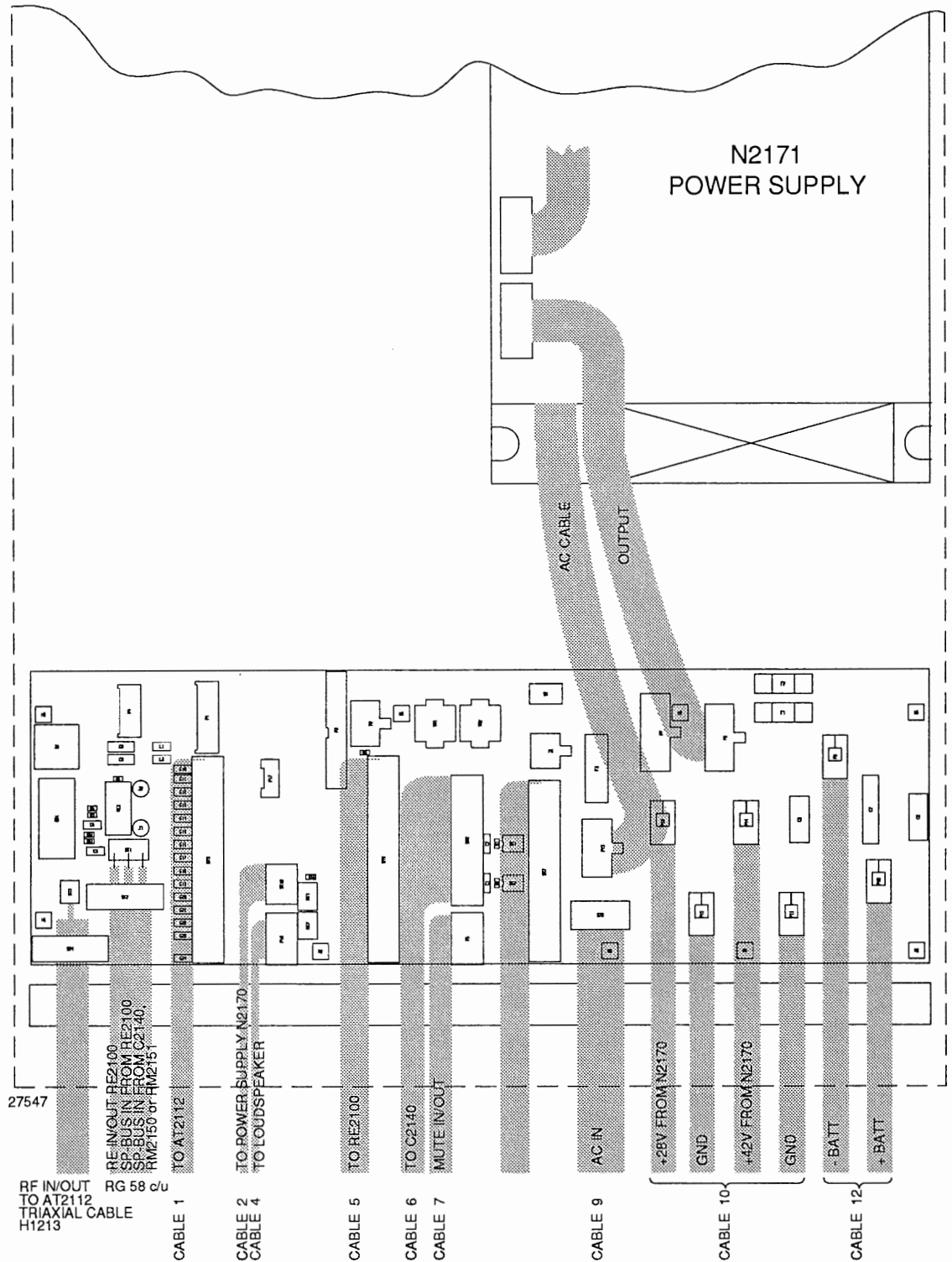

FOR CABLE DIMENSIONS: SEE PART I CHAPTER 2. INSTALLATION

CONNECTION TO N2171 DUAL

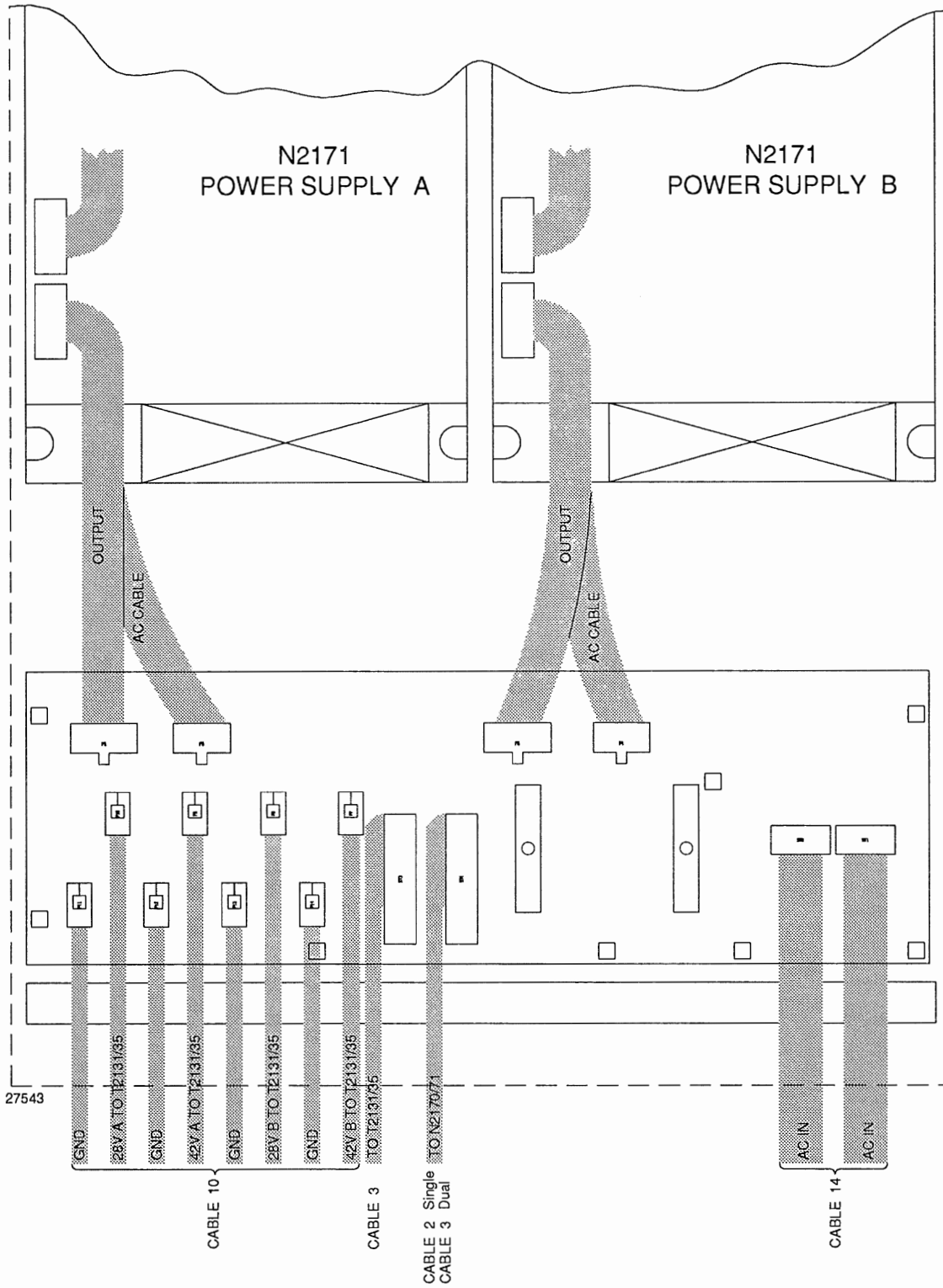

CONTENTS

3	SERVICE	3-1
3.1	MAINTENANCE	3-1
3.2	RECOMMENDED TEST EQUIPMENT	3-1
3.3	TROUBLE SHOOTING	3-1
3.4	PERFORMANCE CHECK	3-1
3.5	NECESSARY CHECK AND ADJUSTMENT AFTER REPAIR	3-2

3 SERVICE

3.1 MAINTENANCE

When the SAILOR N2171 has been correctly installed, the maintenance of the power supply can, dependent on the environments and working hours, be reduced to a performance check at the service workshop at intervals not exceeding 5 years.

A performance check list is enclosed in the section 3.4. PERFORMANCE CHECK.

Also inspect cables and plugs for mechanical defects and corrosion.

Any repair of the set should be followed by a check described in the section 3.5. NECESSARY ADJUSTMENT AND CHECK AFTER REPAIR.

3.2 RECOMMENDED TEST EQUIPMENT

Multimeter:	Philips PM2518X
Oscilloscope:	Philips PM3214

3.3 TROUBLE SHOOTING

Trouble shooting, repair and check of the N2171 should only be performed by persons, who have the sufficient technical knowledge and the necessary test equipment at their disposal.

To do some service on the 28V regulator (module 1), the blower frame can be turned upwards and placed in a service position (see chapter 4.1. MECHANICAL DISASSEMBLING AND MODULE LOCATION). When placed in service position, AC mains may be connected and the N2171 can work normally even with full load.

1. The 28V output is too high:
 - a) A regulator FET (Q1 to Q4) is short-circuited.
 - b) Regulation circuit is out of order.
2. No output voltage at 28V and 42V output:
 - a) Fuse F1 or fuse F2 is blown.
3. No 28V output:
 - a) The thermal breaker TB1-3 is activated (maybe blower failure), heatsink too hot.
4. The blower is always running:
 - a) The 28V is loaded too much in receive mode for the set, which activates the thermal breaker TB2-3. With normal load (less than 3A) on the 28V output in receive mode, the blower starts and stops frequently.
 - b) The 42V regulator module is always switched on.
 - c) Failure in the blower circuit, the transistor Q6-1 is short-circuited.

3.4 PERFORMANCE CHECK

To handle the performance check in an easy way it is recommended to connect the N2171 to a disconnected connection board (module 5 or module 13).

Any value, which differs too much from the values given in this chapter, should lead to a repair of the circuit or module in question.

Hints to locate some faults are given in the chapter 3.3. TROUBLE SHOOTING.

3.4.1 PERFORMANCE CHECK OF 28V AND 42V OUTPUT

1. Connect the N2171 to the AC mains, which it is strapped for. See 5.3. MAIN SCHEMATIC DIAGRAM. Normally the N2171 is strapped for 220V AC.
2. Connect a small dummy load to the 42V output. A resistor of 330 ohm/6W is sufficient to get a proper regulation.
3. To switch on the outputs, an external 15V supply can be connected to the 28V ON, and the 42V ON terminals.
An alternative is to connect a wire to the 15V regulator U1-2 pin 3 and then connect it to the 28V ON and the 42V ON terminals.
4. With a voltmeter across the outputs, read the 28V output to 27.0V \pm 1V with no load connected.
Read the 42V output to 42.2V \pm 0,5V.
Check that the blower is running while the outputs are switched on.

3.4.2 PERFORMANCE CHECK OF 42V CURRENT LIMITER

1. A new dummy load of 1,46 ohm/1000W is connected to the 42V output. It can be made by parallelling several resistors.
2. Switch on **both** outputs to start the blower.
With a voltmeter read the 42V output to 36,5 \pm 1V. The output current is then limited to 25A.
If load is suddenly removed, the 42V output voltage can rise to approx. 50V for a while. This is normal and do no harm.
Check with an oscilloscope the output ripple to max. 2,5V_{pp} at full load.
3. There is no current limiter for the 28V output, but the 28V regulator module should be able to deliver 7,5A with a voltage drop of approx. 1V.
Check with an oscilloscope the output ripple to max. 0,3V_{pp} at full load.

3.5 NECESSARY CHECK AND ADJUSTMENT AFTER REPAIR

Change or repair of the 28V regulator (module 1) or the 42V regulator (module 2):

Execute chapter 3.4.1. PERFORMANCE CHECK OF 28V AND 42V OUTPUT and adjust if necessary the 42V to 42,2 \pm 0,2V DC with R11-2.

There is no adjustment for the 28V output.

Execute chapter 3.4.2. PERFORMANCE CHECK OF 42V CURRENT LIMITER and adjust if necessary the 42V current limiter with R42-2 to give an output voltage of 36,5V \pm 0,2V DC at a full load of 25A. Check with an oscilloscope the output ripple to max. 2,5V_{pp} at full load.

Check also the 28V output ripple to max. 0,3V_{pp} at a load of 7,5A.

CONTENTS

4	MECHANICAL DESCRIPTION	4-1
4.1	MECHANICAL ASSEMBLING / DISASSEMBLING AND UNITS LOCATION	4-1

4 MECHANICAL DESCRIPTION

4.1 MECHANICAL ASSEMBLING / DISASSEMBLING AND UNITS LOCATION

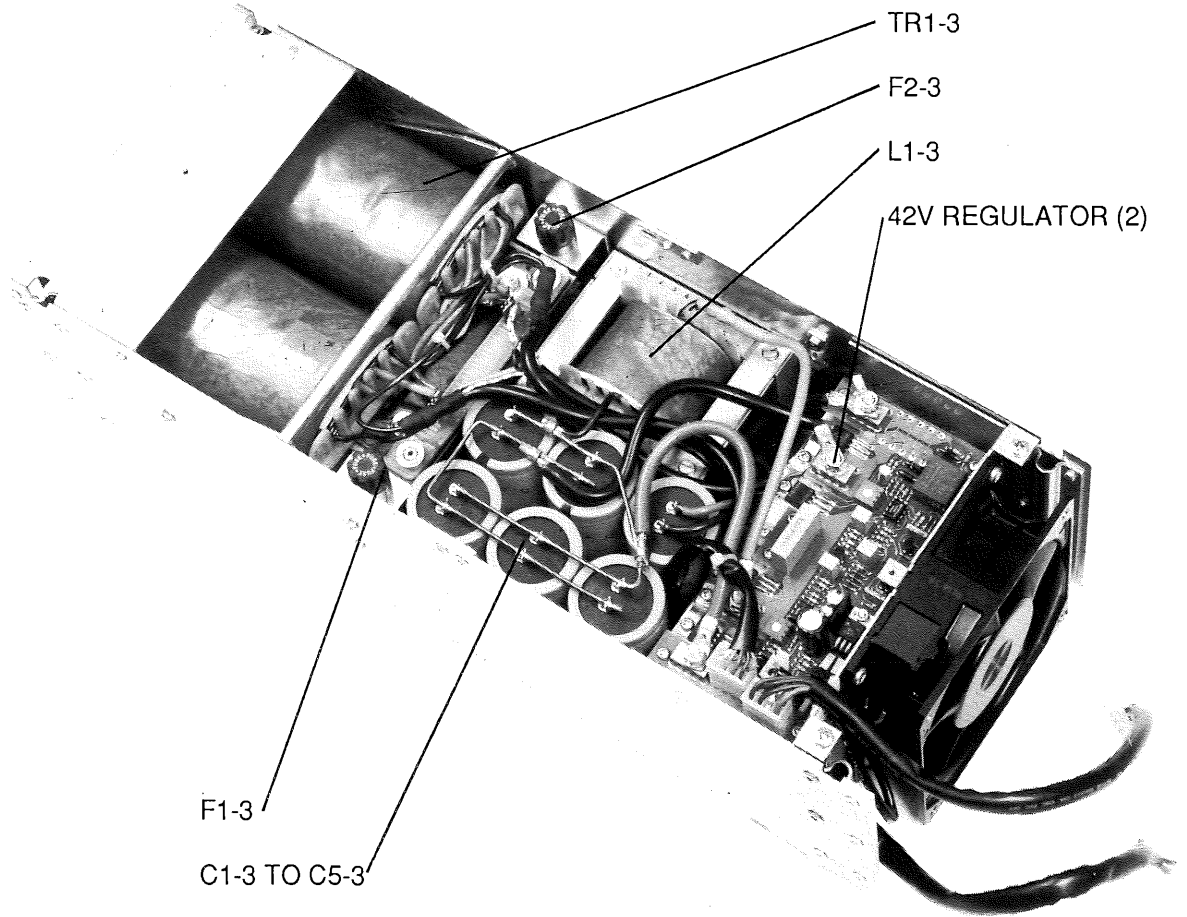

501131

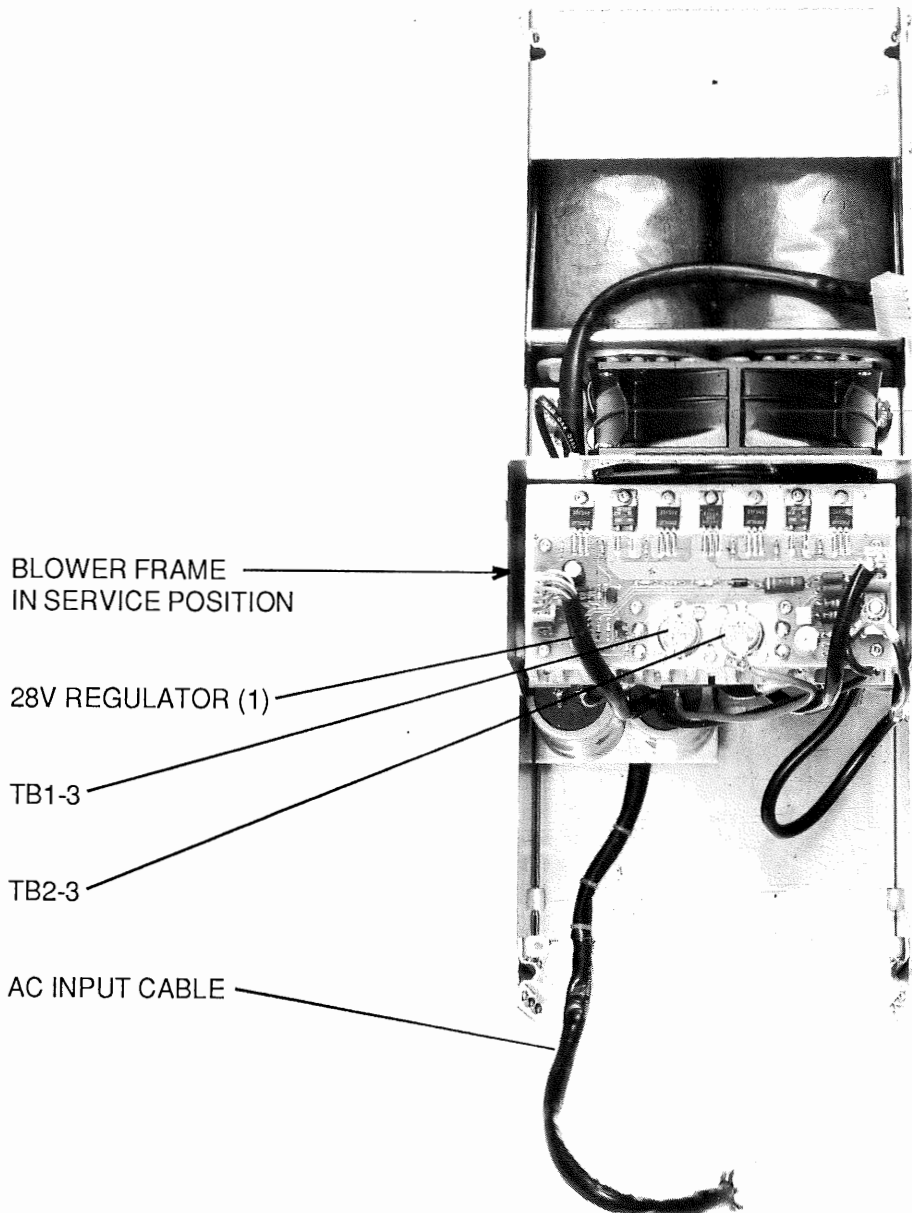

501133

CONTENTS

5	CIRCUIT DESCRIPTION AND SCHEMATIC DIAGRAMS	
5.1	28V REGULATOR (MODULE 1) PART NO. 626431	5-1
5.2	42V REGULATOR (MODULE 2) PART NO. 626432	5-5
5.3	MAIN SCHEMATIC DIAGRAMME N2171	5-11

5 CIRCUIT DESCRIPTION AND SCHEMATIC DIAGRAMS

5.1 28V REGULATOR (MODULE 1) PART NO. 626431

The 32V AC from the mains transformer TR1-3 is led to the bridge rectifier D1, D2 and D3. The current is led to a smoothing capacitor C6-3 and to the regulator FET's Q1 to Q4, which control the output voltage, determined by the resistors R15 and R16.

If the output voltage increases, it causes the regulator diode D10 to open more, which will lower the gate voltages to the FET's. The FET's will close more and the output voltage falls.

If the output voltage should decrease, the circuit works in the opposite way. It is necessary that the gate voltage is higher than the output voltage. This is done by connecting D4 and D5 to the 54V AC from the mains transformer TR1-3 and stabilizing it by means of R4, R6, C2 and D6. The gate voltage can be turned on or off by means of Q5 and Q7, and thus also the output voltage. The 28V on/off signal is produced by the TX processor.

The diodes D7 and D8 are protecting diodes.

The resistors R1, R2 and R3 reduce the input voltages for the 15V regulator U1-2 placed in the 42V regulator module.

The transistor Q6 turns on the blower BL1-3 when the 42V output is switched on. If the temperature of the 28V regulator heatsink exceeds 70°C, the thermal breaker TB2-3 switches on and turns on the blower by means of Q6, until the temperature is below 55°C. If the heatsink temperature exceeds 90°C, in case of blower failure, the thermal breaker TB1-3, switches off and the 28V output will then turn off until the temperature is below approx. 75°C.

COMPONENT LOCATION 28V REGULATOR MODULE 1

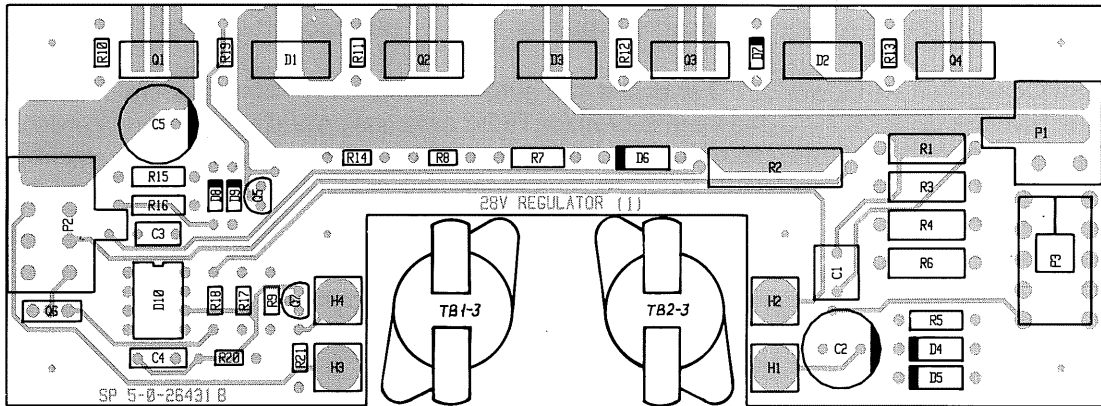

View from component side with upper side tracks.

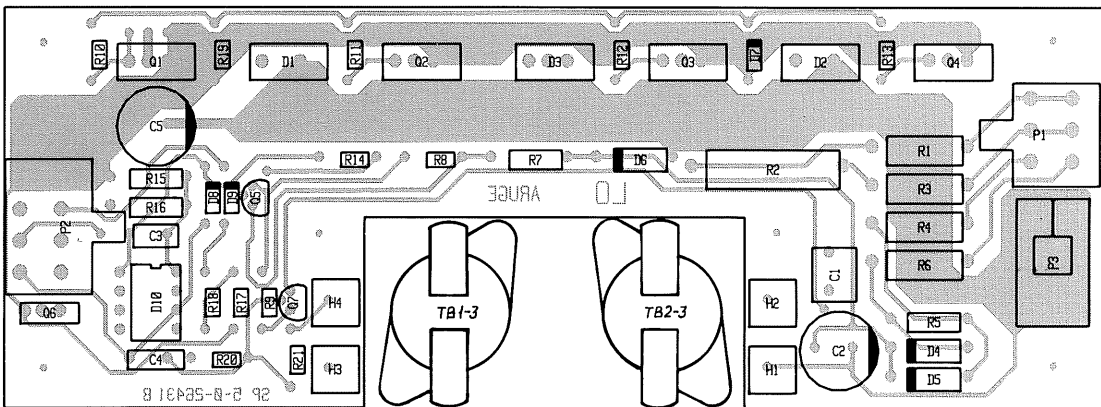

View from component side with lower side tracks.

28V REGULATOR MODULE 1

28V Regulator (1)

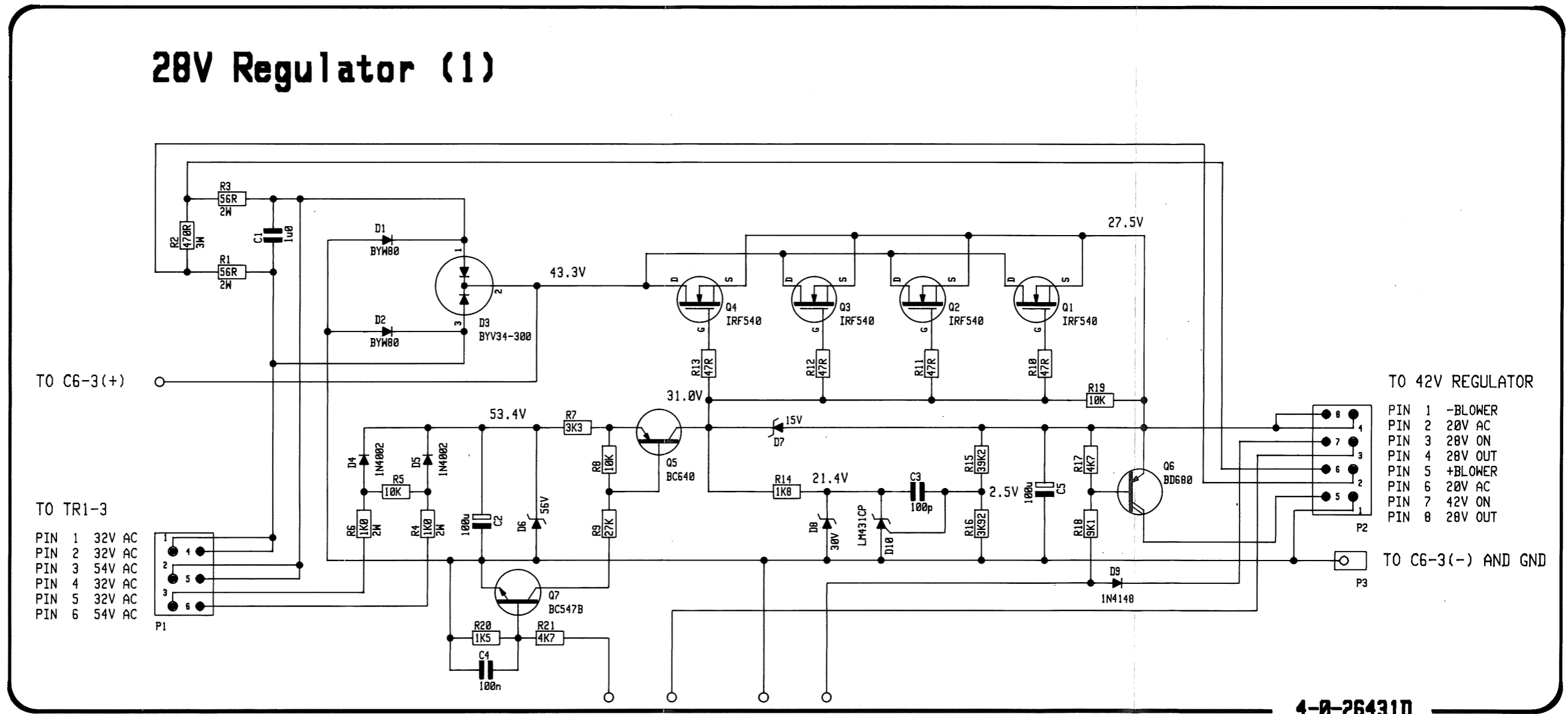

4-0-26431D

TO C6-3(+)

TO TR1-3

- PIN 1 32V AC
- PIN 2 32V AC
- PIN 3 54V AC
- PIN 4 32V AC
- PIN 5 32V AC
- PIN 6 54V AC

TO 42V REGULATOR

- PIN 1 -BLOWER
- PIN 2 20V AC
- PIN 3 28V ON
- PIN 4 28V OUT
- PIN 5 +BLOWER
- PIN 6 20V AC
- PIN 7 42V ON
- PIN 8 28V OUT

TO C6-3(-) AND GND



4-0-26431D

5.2 42V REGULATOR (MODULE 2) PART NO. 626432

From the mains transformer TR1-3 the 54V AC is led to the rectifier bridge consisting of D23 and D24, Q1 and Q2. The current is then led to the output smoothing filter L1-3 and C1-3 to C5-3 which reduces the output ripple on the 42V output.

The module produces the necessary pulses to the thyristors Q1 and Q2 which are the stabilizing elements for the 42V output voltage.

20V AC from the mains transformer TR1-3 is rectified by the diodes D3 and D4. This full wave rectified sine wave is then peak rectified by D5 and C2 and led to U1. This is a fixed 15V voltage regulator, which delivers all the supply current to the other components on the board. The full wave rectified sine wave is in addition led to the base of Q8 through R4. Q1 is conducting most of the time, but is off for a short period around the zero crossing of the sine wave. In this short period Q7 is conducting and discharges C4 through D7. C4 is discharged down to approx. 0.7V, the forward voltage of D7. The voltage on pin 3 on U2,1 is then nearly zero.

When Q7 stops conducting, this voltage rises instantly with two forward diode voltages from D6 and D7. C4 starts to be charged by R8 and D6. The voltage on pin 3 now rises with a nearly constant slope. Q7 starts discharging C4 again, etc. This takes place two times every period of the mains frequency. This ramp voltage is compared with the control voltage at the common point of R16, D17 and D18 by U2,1. If the ramp voltage is smaller than the control voltage, the output pin 1 of U2,1 is low. The combination of Q4 and Q6 makes a 7 kHz astable multivibrator. The diodes D8 and D9 eliminate the influence of spreads in base-emitter break-down voltages of the transistors.

This 7 kHz is gated together with the signal from the comparator U2,1 and fed to Q3. If the voltage on pin 1 at U2,1 is low, the 7 kHz signal is not allowed to pass to Q3. D12 ensures a proper turn on and off of Q3, which acts as a constant AC current source to the trigger transformer TR1. The current is determined by the supply voltage, R26, R29 and D12 to approx. 100 mA. The combination D13 and D14 demagnetizes TR1.

The current signal is amplified by a factor 3:1:1 by TR1, rectified by D19 and D20 and led to the thyristors. R32 and R33 prevent false triggering of the thyristors.

The control voltage can never be less than approx. 0.7V due to R27 and R28, but the ramp voltage is always less than 0.7V every time the mains frequency is zero crossing. Therefore, pin 1 at U2,1 goes low and prevents the 7 kHz trigger signal from reaching the thyristors. The thyristors are thus ensured a proper turn off of one thyristor before the other is turned on.

If the on/off terminal pin 6 in P5 is floating, the transistor Q5 will pull up the control voltage point to approx. 14V. The maximum voltage of the ramp voltage is approx. 8V, so the output voltage of U2,1 is then permanently low, and no trigger signal is led to the thyristors. If the on/off terminal is connected to 15V, Q5 is reverse biased by means of Q9 and has no influence on the control voltage.

By varying the control voltage, the moment of triggering the thyristors on sine wave is varied, and thus the output voltage.

The 42V output voltage is sensed by the common mode amplifier U3,1 and divided down to 3.8V. A common mode amplifier is used to remove the sensitivity to noise. This voltage is compared to the reference voltage from D15, divided by R10, R11, and R12. The difference is amplified by U3,2 (voltage error amplifier) and led by D16 and D17 to the control voltage point.

The output current is sensed by R45 to R49 to create a sense voltage. This voltage is compared with a reference voltage produced by D21, R41, R42, and R43 in the common mode amplifier U2,2. The two resistors R34 and R36 offset the amplifier to ensure that the input common mode voltage range of U2,2 is not exceeded. The error voltage is fed to the control voltage point at D18.

The diodes D16, D17, and D18 ensure that the highest voltage of the error voltages has the highest priority. The output voltage is adjusted by R11

The output current is adjusted by R42.

COMPONENT LOCATION 42V REGULATOR MODULE 2

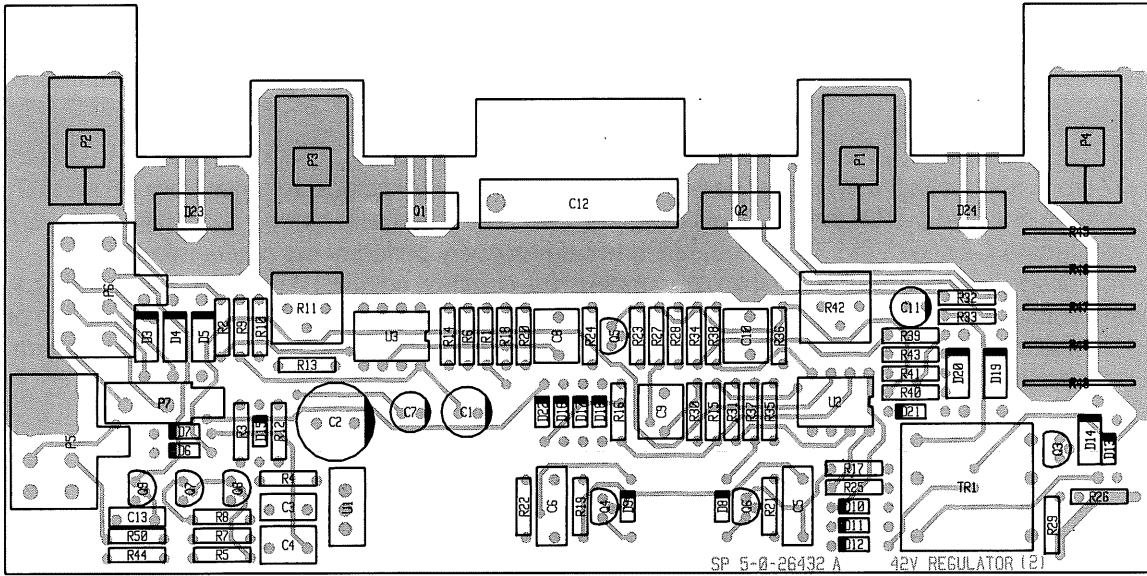

View from component side with upper side tracks.

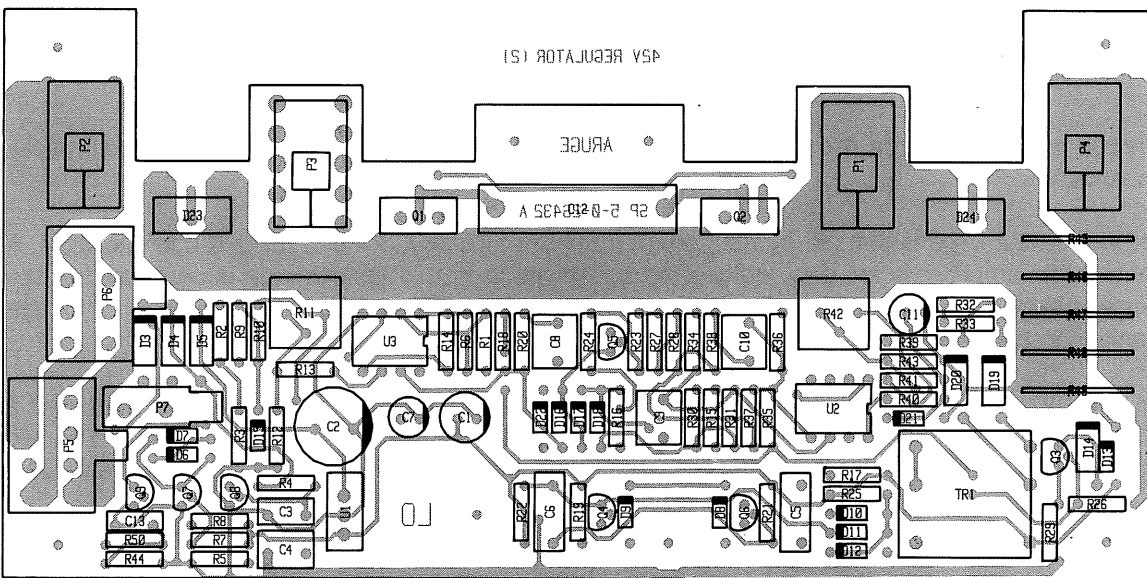

View from component side with lower side tracks.

42V REGULATOR MODULE 2

42V Regulator (2)

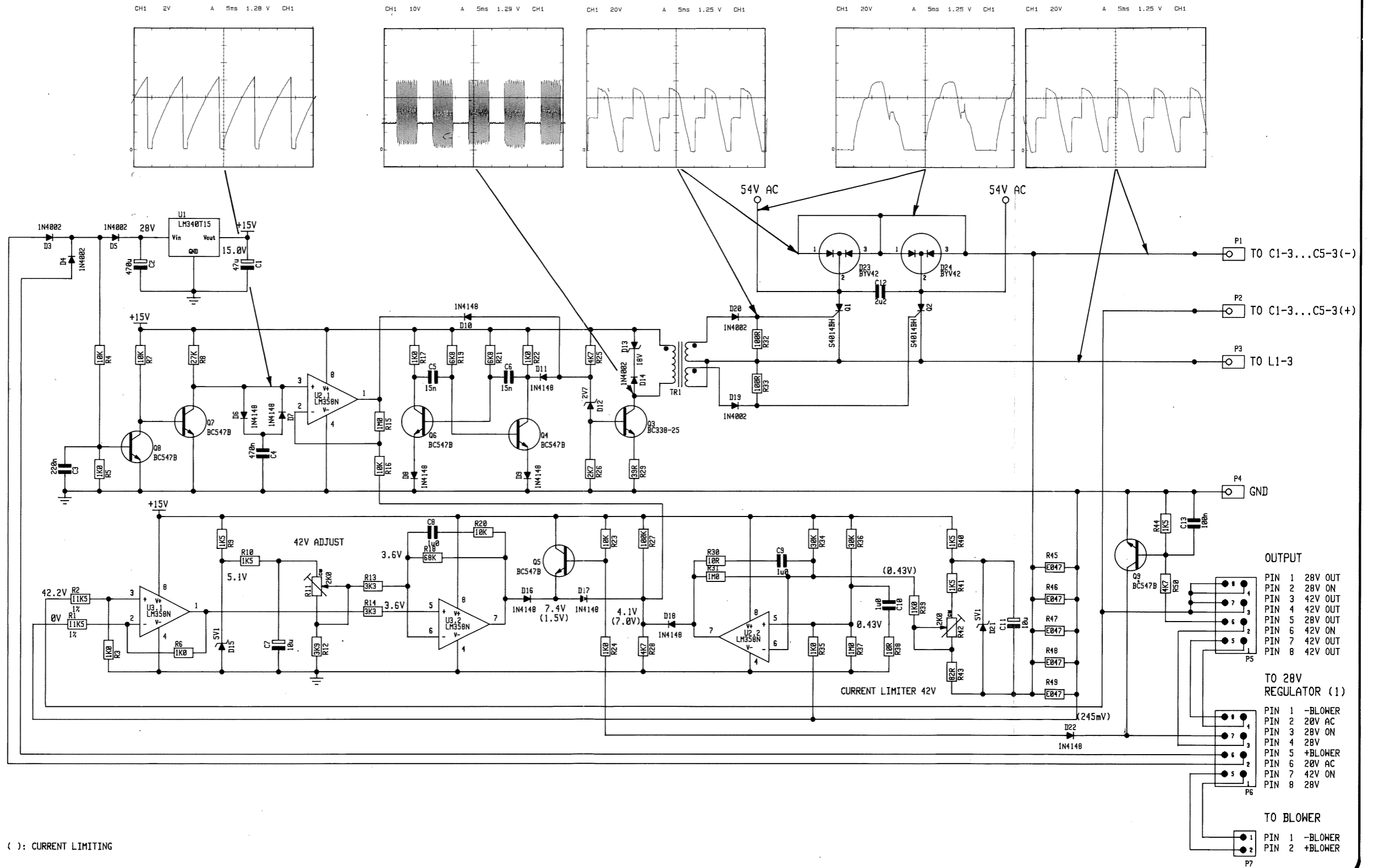

4-0-26432D

4-0-26432D

5.3 MAIN SCHEMATIC DIAGRAMME N2171

MAIN SCHEMATIC DIAGRAMME N2171

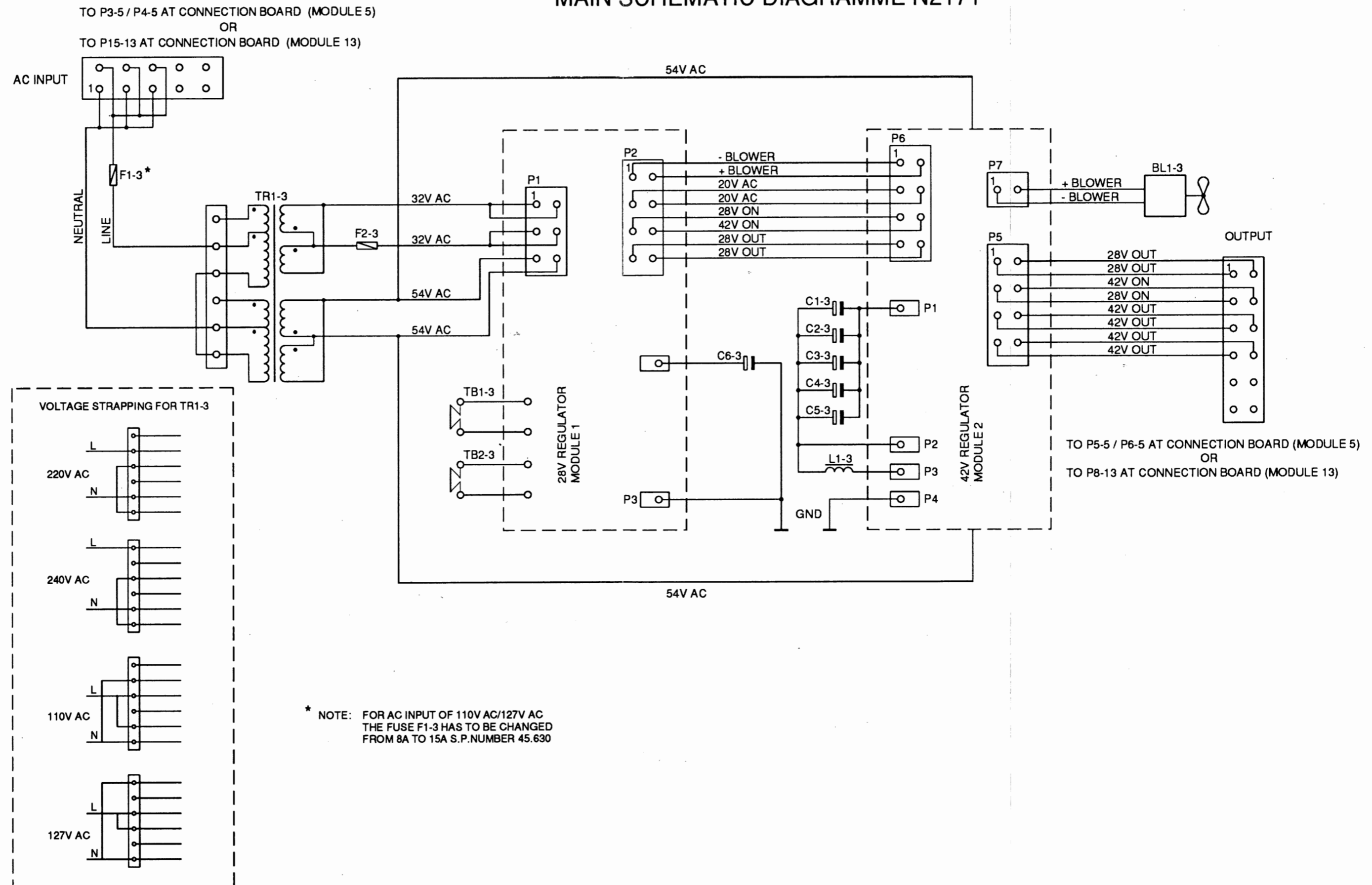

26984

CONTENTS

6 PARTS LISTS

6-1

6 PARTS LISTS

P.S.UNIT, AC, 600W, N2171		HF SSB PROGRAMME	ECI A/S	0-0-26430	726430
POSITION	DESCRIPTION		MANUFACTOR	TYPE	PART NO.
VARIOUS	OUTPUT CABLE N2171/600W		ECI A/S	3-0-26512	526512
VARIOUS	INTERCON.CABLE N2171/600W		ECI A/S	3-0-26513	526513
VARIOUS	28V CABLE N2171/600W		ECI A/S	3-0-26514	526514
VARIOUS	AC SUPPLY CABLE N2171/600		ECI A/S	3-0-26515	526515
VARIOUS	BLOWER CABLE N2171/600W		ECI A/S	3-0-26516	526516
VARIOUS	SPARE FUSES FOR N2171		ECI A/S	0-0-27006	727006
VARIOUS	1 POLE FUSEHOLDER	342.014	WICKMANN	342.014	78.393
				HFCGKN TYPE TAPTITE	88.401
				HFC 266 M3x10 PHJX-Z	
-1	28V REGULATOR UNIT	MODULE (1) N2171	ECI A/S	5-0-26431B / 4-0-26431D	626431
-2	42V REGULATOR UNIT	MODULE (2) N2171	ECI A/S	5-0-26432A / 4-0-26432D	626432
BL1-3	FAN 24VDC	119x119x38mm	PAPST	4124 KX	60.100
C1-3	CAPACITOR ELECTROLYTIC	10000uF -10/+50% 63VDC	PHILIPS	2222 050 68103 & 4322 043 05581 & 4322 043 05561	14.870
C2-3	CAPACITOR ELECTROLYTIC	10000uF -10/+50% 63VDC	PHILIPS	2222 050 68103 & 4322 043 05581 & 4322 043 05561	14.870
C3-3	CAPACITOR ELECTROLYTIC	10000uF -10/+50% 63VDC	PHILIPS	2222 050 68103 & 4322 043 05581 & 4322 043 05561	14.870
C4-3	CAPACITOR ELECTROLYTIC	10000uF -10/+50% 63VDC	PHILIPS	2222 050 68103 & 4322 043 05581 & 4322 043 05561	14.870
C5-3	CAPACITOR ELECTROLYTIC	10000uF -10/+50% 63VDC	PHILIPS	2222 050 68103 & 4322 043 05581 & 4322 043 05561	14.870
C6-3	CAPACITOR ELECTROLYTIC	10000uF -10/+50% 63VDC	PHILIPS	2222 050 68103 & 4322 043 05581 & 4322 043 05561	14.870
F1/220V	FUSE	8AM 6.3x32mm	LITTELFUSE	311008	45.628
				RS.143-150	
F2-3	FUSE	15AM Ø6.3x32mm	LITTELFUSE	311015	45.630
F1/110V	FUSE	15AM Ø6.3x32mm	LITTELFUSE	311015	45.630
L1-3	CHOKE FIXED	2mH/23A 50Hz	DANTRAF0 A/S	6-0-26931A	20.256
				Art.Nr: DT2247	
TB1-3	THERMAL BREAKER	OFF:88 ON:77	* COMEPA	25 2 98 21 088 077	44.001
TB2-3	THERMAL BREAKER	ON:70 OFF:55	* COMEPA	25 0 98 21 070 055	44.011
TR1-3	TRANSFORMER MAINS	N2171 1k3VA	DANTRAF0 A/S	6-0-26932A	22.512
				Art.Nr: DT2246	

28V REGULATOR UNIT		MODULE (1) N2171	ECI A/S	5-0-26431B / 4-0-26431D	626431
POSITION	DESCRIPTION		MANUFACTOR	TYPE	PART NO.
C1-1	CAPACITOR MKT	1uF 5% 63VDC	ERO	MKT 1826-510/06 4-G	11.190
C2-1	CAPACITOR ELECTROLYTIC	100uF -20/+50% 63VDC	ELNA	RJ2-63-V-101-M-F	14.620
C3-1	CAPACITOR CERAMIC	100pF 5% NPO 50VDC	KCK	RT-HE80 SK CH 101 J	15.136
C4-1	CAPACITOR MKT	100nF 5% 63VDC	PHILIPS	2222 370 79104	11.135
C5-1	CAPACITOR ELECTROLYTIC	100uF -20/+50% 63VDC	ELNA	RJ2-63-V-101-M-F	14.620
D1-1	DIODE F.REC	7A/150V BYW80-150	THOMSON-CSF	BYW80-150	27.625
D2-1	DIODE F.REC	7A/150V BYW80-150	THOMSON-CSF	BYW80-150	27.625
D3-1	DIODE DUAL 2x10A/300VDC	TO-220 BYV34-300	PHILIPS	BYV34-300 (-400-500)	27.158
D4-1	DIODE RECTIFIER	1N4002 100V/1A	THOMSON	1N4002 (03/04/05/06/07)	25.100
D5-1	DIODE RECTIFIER	1N4002 100V/1A	THOMSON	1N4002 (03/04/05/06/07)	25.100
D6-1	DIODE ZENER	56V 5%	THOMSON-CSF	BZV47C56	26.788
D7-1	DIODE ZENER	15V 5% 0.4W BZX79C15	PHILIPS	BZX79C15	26.561
D8-1	DIODE ZENER	30V 5% 0.4W BZX79C30	PHILIPS	BZX79C30	26.578
D9-1	DIODE	1N4148 HIGH SPEED	PHILIPS	1N4148-143	25.131
D10-1	DIODE SHUNT REGULATOR	PROGRAMMABLE TL431C	TEXAS	TL431CP	26.997
P1-1	MULTIPLUG	2x3 POLES PCB VERSION	MOLEX	39-28-1063	78.217
P2-1	MULTIPLUG	2x4 POLES PCB VERSION	MOLEX	39-28-1083	78.218
P3-1	CONNECTION ELEMENT	FOR M5 SCREW	ECI A/S	1-0-25860	225860
Q1-1	TRANS.POW.MOSFET N-CHANN.	100V/27A/85mOHM IRF540	MOTOROLA	IRF540	29.402
Q2-1	TRANS.POW.MOSFET N-CHANN.	100V/27A/85mOHM IRF540	MOTOROLA	IRF540	29.402
Q3-1	TRANS.POW.MOSFET N-CHANN.	100V/27A/85mOHM IRF540	MOTOROLA	IRF540	29.402
Q4-1	TRANS.POW.MOSFET N-CHANN.	100V/27A/85mOHM IRF540	MOTOROLA	IRF540	29.402
Q5-1	TRANSISTOR	BC640	PHILIPS	BC640	28.124
Q6-1	TRANSISTOR	BD680	PHILIPS*	BDX47	29.338
Q7-1	TRANSISTOR AF	BC547B NPN TO-92	PHILIPS	BC547B	28.067

POSITION	DESCRIPTION		MANUFACTOR	TYPE	PART NO.
R1-1	RESISTOR PMF	56 OHM 5% 2W	PHILIPS	2322 194 13569	04.149
R2-1	RESISTOR PMF	470 OHM 5% 3W	PHILIPS	2322 195 13471	04.691
R3-1	RESISTOR PMF	56 OHM 5% 2W	PHILIPS	2322 194 13569	04.149
R4-1	RESISTOR PMF	1k0 OHM 5% 2W	PHILIPS	2322 194 13102	04.200
R5-1	RESISTOR MF	10k OHM 5% 0.4W	PHILIPS	2322 181 53103	01.225
R6-1	RESISTOR PMF	1k0 OHM 5% 2W	PHILIPS	2322 194 13102	04.200
R7-1	RESISTOR MF	3k3 OHM 5% 0.4W	PHILIPS	2322 181 53332	01.212
R8-1	RESISTOR MF	10k OHM 5% 0.33W	PHILIPS	2322 187 73103	02.496
R9-1	RESISTOR MF	27k OHM 5% 0.33W	PHILIPS	2322 187 73273	02.506
R10-1	RESISTOR MF	47 OHM 5% 0.33W	PHILIPS	2322 187 73479	02.440
R11-1	RESISTOR MF	47 OHM 5% 0.33W	PHILIPS	2322 187 73479	02.440
R12-1	RESISTOR MF	47 OHM 5% 0.33W	PHILIPS	2322 187 73479	02.440
R13-1	RESISTOR MF	47 OHM 5% 0.33W	PHILIPS	2322 187 73479	02.440
R14-1	RESISTOR MF	1k8 OHM 5% 0.33W	PHILIPS	2322 187 73182	02.478
R15-1	RESISTOR MF	39k2 OHM 1% 0.6W	PHILIPS	2322 156 13923	03.439
R16-1	RESISTOR MF	3k92 OHM 1% 0.6W	PHILIPS	2322 156 13922	03.409
R17-1	RESISTOR MF	4k7 OHM 5% 0.33W	PHILIPS	2322 187 73472	02.488
R18-1	RESISTOR MF	9k1 OHM 5% 0.33W	PHILIPS	2322 187 73912	02.495
R19-1	RESISTOR MF	10k OHM 5% 0.33W	PHILIPS	2322 187 73103	02.496
R20-1	RESISTOR MF	1k5 OHM 5% 0.33W	PHILIPS	2322 187 73152	02.476
R21-1	RESISTOR MF	4k7 OHM 5% 0.33W	PHILIPS	2322 187 73472	02.488

42V REGULATOR UNIT	MODULE (2) N2171	ECI A/S	5-O-26432A / 4-O-26432D	626432
--------------------	------------------	---------	-------------------------	--------

POSITION	DESCRIPTION		MANUFACTOR	TYPE	PART NO.
C1-2	CAPACITOR ELECTROLYTIC	47uF 20% 25VDC	ELNA	RJ2-25-V-470-M-F1	14.524
C2-2	CAPACITOR ELECTROLYTIC	470uF -20/+50% 40VDC	ERO	EKM 05 FG 347 G 05	14.650
C3-2	CAPACITOR MKT	220nF 10% 63VDC	PHILIPS	2222 370 78224	11.095
C4-2	CAPACITOR MKT	470nF 20% 63VDC	ERO	MKT 1826-447/06 6-G	11.188
C5-2	CAPACITOR MKT	15nF 5% 250V	ERO	MKT1818	11.170
C6-2	CAPACITOR MKT	15nF 5% 250V	ERO	MKT1818	11.170
C7-2	CAPACITOR ELECTROLYTIC	10uF 20% 35VDC	ELNA	RJ2-35-V-100-M-T34(T58)	14.512
C8-2	CAPACITOR MKT	1uF 5% 63VDC	ERO	MKT 1826-510/06 4-G	11.190
C9-2	CAPACITOR MKT	1uF 5% 63VDC	ERO	MKT 1826-510/06 4-G	11.190
C10-2	CAPACITOR MKT	1uF 5% 63VDC	ERO	MKT 1826-510/06 4-G	11.190
C11-2	CAPACITOR ELECTROLYTIC	10uF 20% 35VDC	ELNA	RJ2-35-V-100-M-T34(T58)	14.512
C12-2	CAPACITOR MKT	2u2F 10% 100VDC	ERO	MKT 1822-522/01 5	11.142
C13-2	CAPACITOR MKT	100nF 5% 63VDC	PHILIPS	2222 370 79104	11.135
D3-2	DIODE RECTIFIER	1N4002 100V/1A	THOMSON	1N4002 (03/04/05/06/07)	25.100
D4-2	DIODE RECTIFIER	1N4002 100V/1A	THOMSON	1N4002 (03/04/05/06/07)	25.100
D5-2	DIODE RECTIFIER	1N4002 100V/1A	THOMSON	1N4002 (03/04/05/06/07)	25.100
D6-2	DIODE	1N4148 HIGH SPEED	PHILIPS	1N4148-143	25.131
D7-2	DIODE	1N4148 HIGH SPEED	PHILIPS	1N4148-143	25.131
D8-2	DIODE	1N4148 HIGH SPEED	PHILIPS	1N4148-143	25.131
D9-2	DIODE	1N4148 HIGH SPEED	PHILIPS	1N4148-143	25.131
D10-2	DIODE	1N4148 HIGH SPEED	PHILIPS	1N4148-143	25.131
D11-2	DIODE	1N4148 HIGH SPEED	PHILIPS	1N4148-143	25.131
D12-2	DIODE ZENER	2V7 5% 0.4W BZX79C2V7	PHILIPS	BZX79C2V7	26.506
D13-2	DIODE ZENER	18V 5% 0.4W BZX79C18	PHILIPS	BZX79C18	26.564
D14-2	DIODE RECTIFIER	1N4002 100V/1A	THOMSON	1N4002 (03/04/05/06/07)	25.100
D15-2	DIODE ZENER	5.1V 5% 0.4W BZX79C5V1	PHILIPS	BZX79C5V1	26.527
D16-2	DIODE	1N4148 HIGH SPEED	PHILIPS	1N4148-143	25.131
D17-2	DIODE	1N4148 HIGH SPEED	PHILIPS	1N4148-143	25.131
D18-2	DIODE	1N4148 HIGH SPEED	PHILIPS	1N4148-143	25.131
D19-2	DIODE RECTIFIER	1N4002 100V/1A	THOMSON	1N4002 (03/04/05/06/07)	25.100
D20-2	DIODE RECTIFIER	1N4002 100V/1A	THOMSON	1N4002 (03/04/05/06/07)	25.100
D21-2	DIODE ZENER	5.1V 5% 0.4W BZX79C5V1	PHILIPS	BZX79C5V1	26.527
D22-2	DIODE	1N4148 HIGH SPEED	PHILIPS	1N4148-143	25.131
D23-2	DIODE DUAL 2x15A/200VDC	TO-220 BNYV42-200	PHILIPS	BYV42-200	27.161
D24-2	DIODE DUAL 2x15A/200VDC	TO-220 BNYV42-200	PHILIPS	BYV42-200	27.161
P1-2	CONNECTION ELEMENT	FOR M5 SCREW	ECI A/S	1-0-25860	225860
P2-2	CONNECTION ELEMENT	FOR M5 SCREW	ECI A/S	1-0-25860	225860
P3-2	CONNECTION ELEMENT	FOR M5 SCREW	ECI A/S	1-0-25860	225860
P4-2	CONNECTION ELEMENT	FOR M5 SCREW	ECI A/S	1-0-25860	225860
P5-2	MULTIPLUG	2x4 POLES PCB VERSION	MOLEX	39-28-1083	78.218
P6-2	MULTIPLUG	2x4 POLES PCB VERSION	MOLEX	39-28-1083	78.218
P7-2	PLUG 2POLES		MOLEX	39-28-1023	78.215
Q1-2	SCR 200V/40A rms TO-220	S4014BH/S4012BH	TAG	S4014BH	29.930

POSITION	DESCRIPTION		MANUFACTURER	TYPE	PART NO.
Q2-2	SCR 200V/40A rms TO-220	S4014BH/S4012BH	TAG	(S4014 DH/MH/NM) S4014BH	29.930
Q3-2	TRANSISTOR AF	BC338-25 NPN TO-92	PHILIPS	(S4014 DH/MH/NM) BC338-25	28.058
Q4-2	TRANSISTOR AF	BC547B NPN TO-92	PHILIPS	BC547B	28.067
Q5-2	TRANSISTOR AF	BC547B NPN TO-92	PHILIPS	BC547B	28.067
Q6-2	TRANSISTOR AF	BC547B NPN TO-92	PHILIPS	BC547B	28.067
Q7-2	TRANSISTOR AF	BC547B NPN TO-92	PHILIPS	BC547B	28.067
Q8-2	TRANSISTOR AF	BC547B NPN TO-92	PHILIPS	BC547B	28.067
Q9-2	TRANSISTOR AF	BC547B NPN TO-92	PHILIPS	BC547B	28.067
R1-2	RESISTOR MF	11k5 OHM 1% 0.25W	PHILIPS	2322 157 11153	02.230
R2-2	RESISTOR MF	11k5 OHM 1% 0.25W	PHILIPS	2322 157 11153	02.230
R3-2	RESISTOR MF	1k0 OHM 5% 0.33W	PHILIPS	2322 187 73102	02.472
R4-2	RESISTOR MF	10k OHM 5% 0.33W	PHILIPS	2322 187 73103	02.496
R5-2	RESISTOR MF	1k0 OHM 5% 0.33W	PHILIPS	2322 187 73102	02.472
R6-2	RESISTOR MF	1k0 OHM 5% 0.33W	PHILIPS	2322 187 73102	02.472
R7-2	RESISTOR MF	10k OHM 5% 0.33W	PHILIPS	2322 187 73103	02.496
R8-2	RESISTOR MF	27k OHM 5% 0.33W	PHILIPS	2322 187 73273	02.506
R9-2	RESISTOR MF	1k5 OHM 5% 0.33W	PHILIPS	2322 187 73152	02.476
R10-2	RESISTOR MF	1k5 OHM 5% 0.33W	PHILIPS	2322 187 73152	02.476
R11-2	PRESET CERMET	2k0 OHM 5% 0.5W	BOURNS	3386P-1-202-11	07.887
R12-2	RESISTOR MF	3k9 OHM 5% 0.33W	PHILIPS	2322 187 73392	02.486
R13-2	RESISTOR MF	3k3 OHM 5% 0.33W	PHILIPS	2322 187 73332	02.484
R14-2	RESISTOR MF	3k3 OHM 5% 0.33W	PHILIPS	2322 187 73332	02.484
R15-2	RESISTOR MF	1M OHM 5% 0.33W	PHILIPS	2322 187 73105	02.544
R16-2	RESISTOR MF	10k OHM 5% 0.33W	PHILIPS	2322 187 73103	02.496
R17-2	RESISTOR MF	1k0 OHM 5% 0.33W	PHILIPS	2322 187 73102	02.472
R18-2	RESISTOR MF	68k OHM 5% 0.33W	PHILIPS	2322 187 73683	02.516
R19-2	RESISTOR MF	6k8 OHM 5% 0.33W	PHILIPS	2322 187 73682	02.492
R20-2	RESISTOR MF	10k OHM 5% 0.33W	PHILIPS	2322 187 73103	02.496
R21-2	RESISTOR MF	6k8 OHM 5% 0.33W	PHILIPS	2322 187 73682	02.492
R22-2	RESISTOR MF	1k0 OHM 5% 0.33W	PHILIPS	2322 187 73102	02.472
R23-2	RESISTOR MF	10k OHM 5% 0.33W	PHILIPS	2322 187 73103	02.496
R24-2	RESISTOR MF	1k0 OHM 5% 0.33W	PHILIPS	2322 187 73102	02.472
R25-2	RESISTOR MF	4k7 OHM 5% 0.33W	PHILIPS	2322 187 73472	02.488
R26-2	RESISTOR MF	2k7 OHM 5% 0.33W	PHILIPS	2322 187 73272	02.482
R27-2	RESISTOR MF	100k OHM 5% 0.33W	PHILIPS	2322 187 73104	02.520
R28-2	RESISTOR MF	4k7 OHM 5% 0.33W	PHILIPS	2322 187 73472	02.488
R29-2	RESISTOR MF	39 OHM 5% 0.33W	PHILIPS	2322 187 73399	02.438
R30-2	RESISTOR MF	10 OHM 5% 0.33W	PHILIPS	2322 187 73109	02.424
R31-2	RESISTOR MF	1M OHM 5% 0.33W	PHILIPS	2322 187 73105	02.544
R32-2	RESISTOR MF	100 OHM 5% 0.33W	PHILIPS	2322 187 73101	02.448
R33-2	RESISTOR MF	100 OHM 5% 0.33W	PHILIPS	2322 187 73101	02.448
R34-2	RESISTOR MF	30k OHM 5% 0.33W	PHILIPS	2322 187 73303	02.507
R35-2	RESISTOR MF	1k0 OHM 5% 0.33W	PHILIPS	2322 187 73102	02.472
R36-2	RESISTOR MF	30k OHM 5% 0.33W	PHILIPS	2322 187 73303	02.507
R37-2	RESISTOR MF	1M OHM 5% 0.33W	PHILIPS	2322 187 73105	02.544
R38-2	RESISTOR MF	10 OHM 5% 0.33W	PHILIPS	2322 187 73109	02.424
R39-2	RESISTOR MF	1k0 OHM 5% 0.33W	PHILIPS	2322 187 73102	02.472
R40-2	RESISTOR MF	1k5 OHM 5% 0.33W	PHILIPS	2322 187 73152	02.476
R41-2	RESISTOR MF	1k5 OHM 5% 0.33W	PHILIPS	2322 187 73152	02.476
R42-2	PRESET CERMET	2k0 OHM 5% 0.5W	BOURNS	3386P-1-202-11	07.887
R43-2	RESISTOR MF	82 OHM 5% 0.33W	PHILIPS	2322 187 73829	02.446
R44-2	RESISTOR MF	1k5 OHM 5% 0.33W	PHILIPS	2322 187 73152	02.476
R45-2	RESISTOR	47m OHM 5% 0.6W	MODULOHM I/S	98247/47U-J-MI-A-1	06.233
R46-2	RESISTOR	47m OHM 5% 0.6W	MODULOHM I/S	98247/47U-J-MI-A-1	06.233
R47-2	RESISTOR	47m OHM 5% 0.6W	MODULOHM I/S	98247/47U-J-MI-A-1	06.233
R48-2	RESISTOR	47m OHM 5% 0.6W	MODULOHM I/S	98247/47U-J-MI-A-1	06.233
R49-2	RESISTOR	47m OHM 5% 0.6W	MODULOHM I/S	98247/47U-J-MI-A-1	06.233
R50-2	RESISTOR MF	4k7 OHM 5% 0.33W	PHILIPS	2322 187 73472	02.488
TR1-2	TRANSFORMER	3:1:1	SCHAFFNER	IT 244	22.000
U1-2	POS. VOLTAGE REG. 15V/1A	MCT7815-MC7815-LM340T-15	MOTOROLA	MCT7815CT (MCT7815BT)	31.090
U2-2	DUAL OP AMP	LM358N	TEXAS	LM358P	31.100
U3-2	DUAL OP AMP	LM358N	TEXAS	LM358P	31.100

TECHNICAL MANUAL FOR BATTERY CHARGER UNIT
(N2174) PART NO. 726440

CONTENTS

1	GENERAL INFORMATION	
1.1	INTRODUCTION	1-1
1.2	PRINCIPLE OF OPERATION	1-1
2	INSTALLATION	
2.1	ELECTRICAL CONNECTIONS AND ASSEMBLING	2-1
3	SERVICE	
3.1	MAINTENANCE	3-1
3.2	RECOMMENDED TEST EQUIPMENT	3-1
3.3	TROUBLE SHOOTING	3-1
3.4	PERFORMANCE CHECK FOR CHARGING LEAD-ACID BATTERIES	3-2
3.5	NECESSARY CHECK AND ADJUSTMENT AFTER REPAIR (Lead-Acid)	3-3
3.6	PERFORMANCE CHECK FOR CHARGING NICKEL CADMIUM BATTERIES	3-4
3.7	NECESSARY CHECK AND ADJUSTMENT AFTER REPAIR (NiCd)	3-6
4	MECHANICAL DESCRIPTION	
4.1	MECHANICAL ASSEMBLING / DISASSEMBLING AND UNITS LOCATION	4-1
5	CIRCUIT DESCRIPTION AND SCHEMATIC DIAGRAMS	
5.1	MANUAL CONTROL (MODULE 1) PART NO. 626444	5-1
5.2	AUTOMATIC CONTROL (MODULE 2) PART NO. 626445	5-1
5.3	MAIN SCHEMATIC DIAGRAM N2174	5-10
6	PARTS LISTS	

CONTENTS

1	GENERAL INFORMATION	1-1
1.1	INTRODUCTION	1-1
1.2	PRINCIPLE OF OPERATION	1-1

GRØN SIDE

1 GENERAL INFORMATION

1.1 INTRODUCTION

The Sailor N2174 Battery Charger is especially developed to charge the **maintenance free** lead-acid batteries and the **Nickel Cadmium** batteries.

The Sailor N2174 is designet in harmony with the Sailor HF SSB Shortwave Programme, but can also stand alone to charge any 24V batteries.

The Sailor N2174 is remote controlled.

1.2 PRINCIPLE OF OPERATION

BLOCKDIAGRAMME FOR N2174

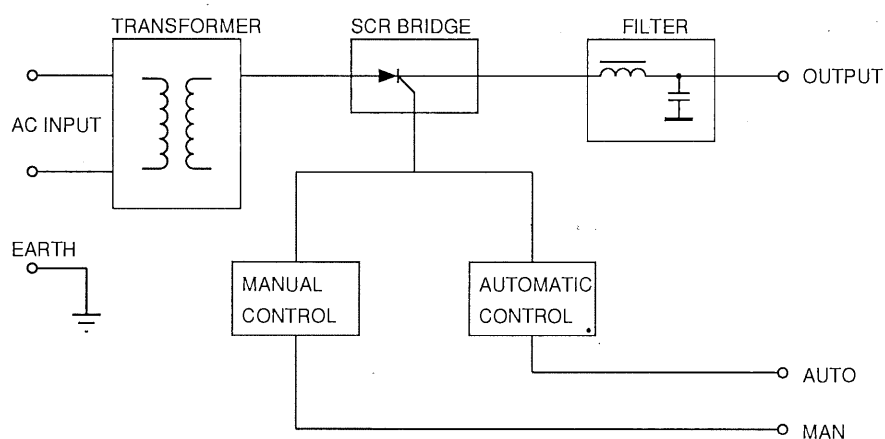

4-0-28121

The Battery Charger N2174 can operate in two ways: **manual mode** or **automatic mode**. The **manual mode** is only recommended to use when the automatic module is out of order, because there is only a simple regulation of the battery charge condition. When using the **manual mode** the battery must be under close supervision even the N2174 from factory is limited to deliver max. 29V and approx. 30 A.

In **automatic mode** the N2174 is charging in two state: Main **Charge** and **Trickle** charge.

In main **charge** mode the N2174 is working as a constant current generator until the battery voltage is reaching the upper level voltage (gassing voltage). At this level the N2174 is changing state to **trickle** charge mode and is now working as a constant voltage generator to maintain a constant voltage to the battery.

To ensure maximum battery capacity the N2174 is provided with remote voltage sense wires. If the battery is loaded more than the charger is able to supply, the battery voltage eventually goes under the lower level voltage which again changes the N2174 into **charge** mode and so on (see figure for *typical charge curve*).

TYPICAL CHARGE CURVE

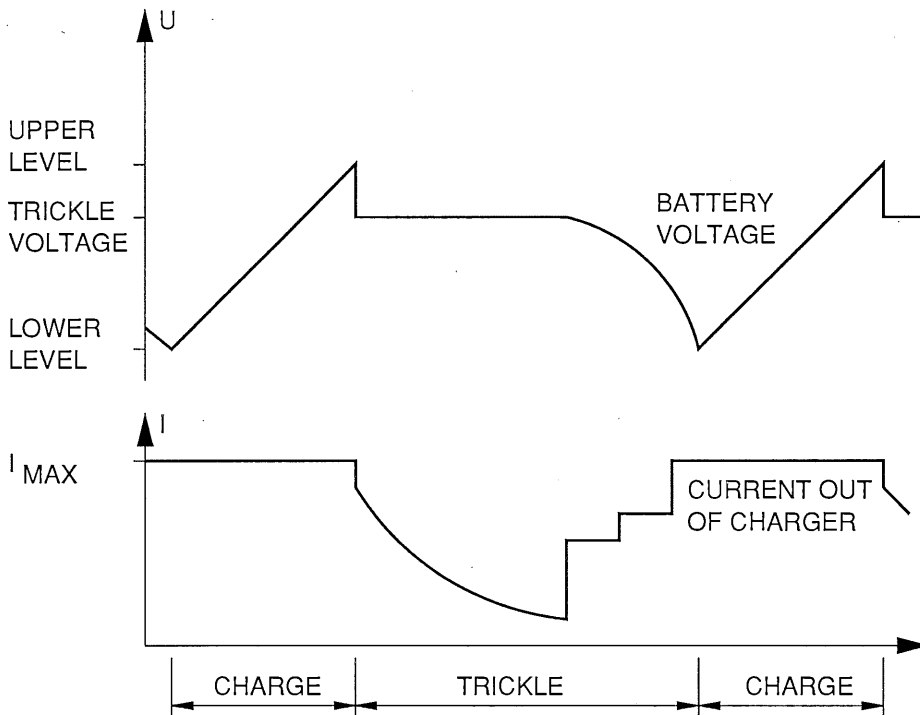

4-0-28234

For charging **Nickel Cadmium** batteries, which demand a higher voltage, a strap is moved on the automatic module followed by an adjustment of the output voltage according to the battery type in question.

If the battery is placed in environment with extreme temperatures, a temperature sensor can be connected to N2174 to correct the charge voltage to prolong the battery lifetime.

The N2174 is designed to be controlled from a remote switch box H2180 or from the console H2192, where the amp. meter and the volt meter are placed. The current **shunt** should be placed remote near the battery e.g. in the fuse box H2182.

The N2174 is also designed to operate two in parallel to deliver a current of 60A. This is done by dedicating one of them to be **master** and the other as **slave**. The configuration is done by moving a strap on the automatic module in the **slave** unit and connect some wires on the connection board.

CONTENTS

2 INSTALLATION

2.1 ELECTRICAL CONNECTIONS AND ASSEMBLING

2-1

GRØN SIDE

2 INSTALLATION

2.1 ELECTRICAL CONNECTIONS AND ASSEMBLING

CONNECTION TO N2174 SINGLE

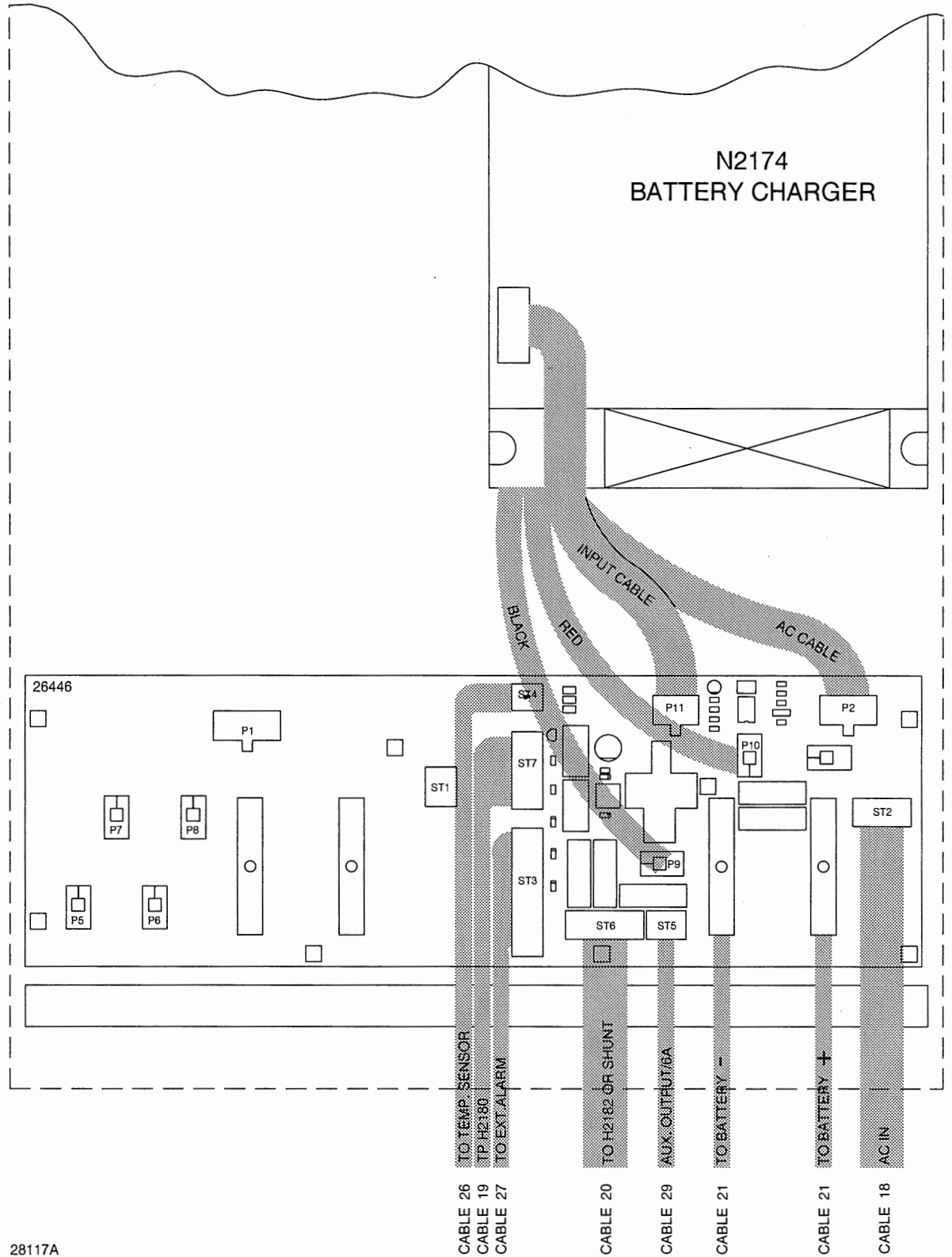

FOR CABLE DIMENSIONS: SEE PART I

CONNECTION TO N2170 AND N2174

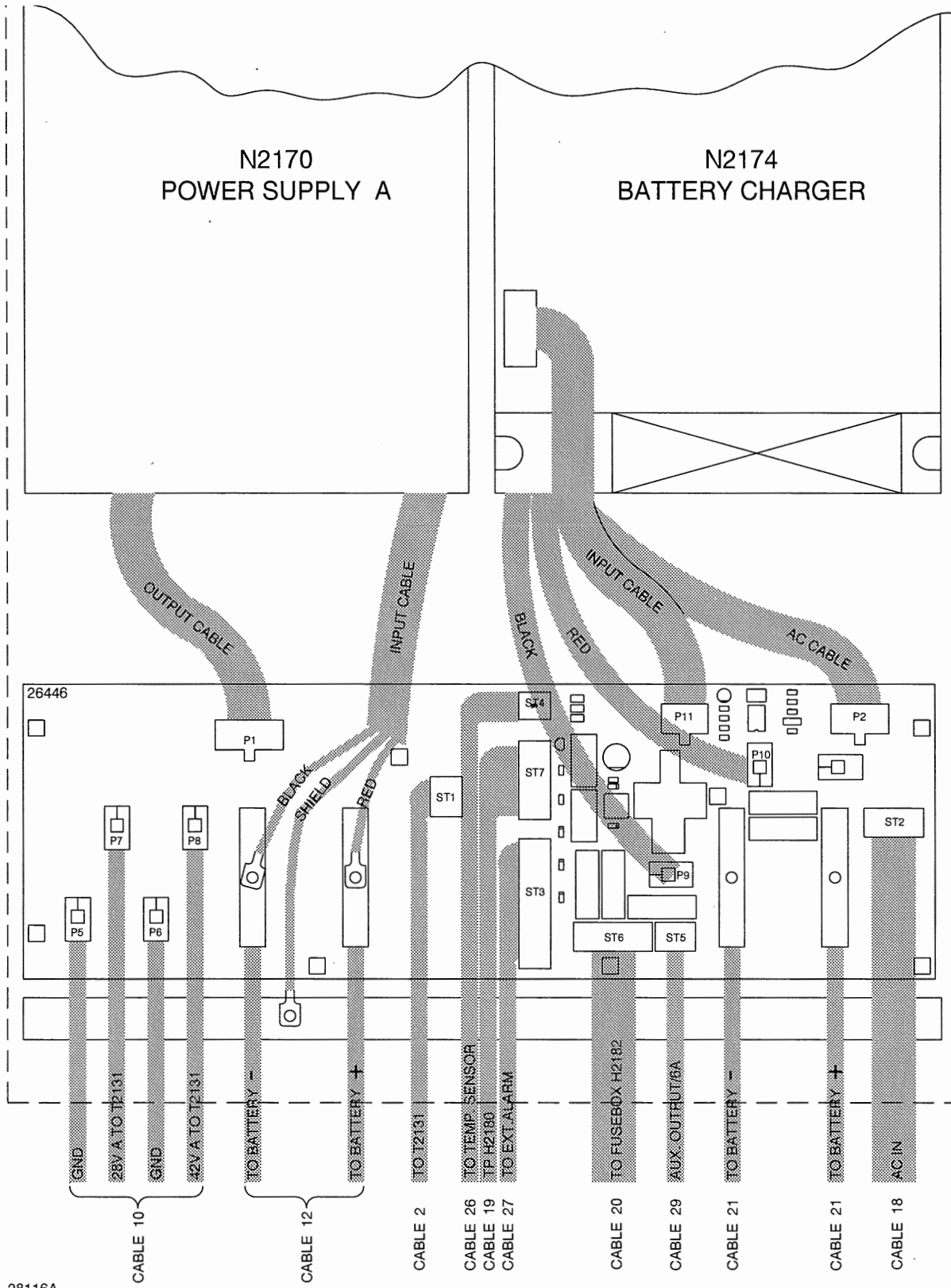

28116A

FOR CABLE DIMENSIONS: SEE PART I

CONNECTION TO N2174 DUAL

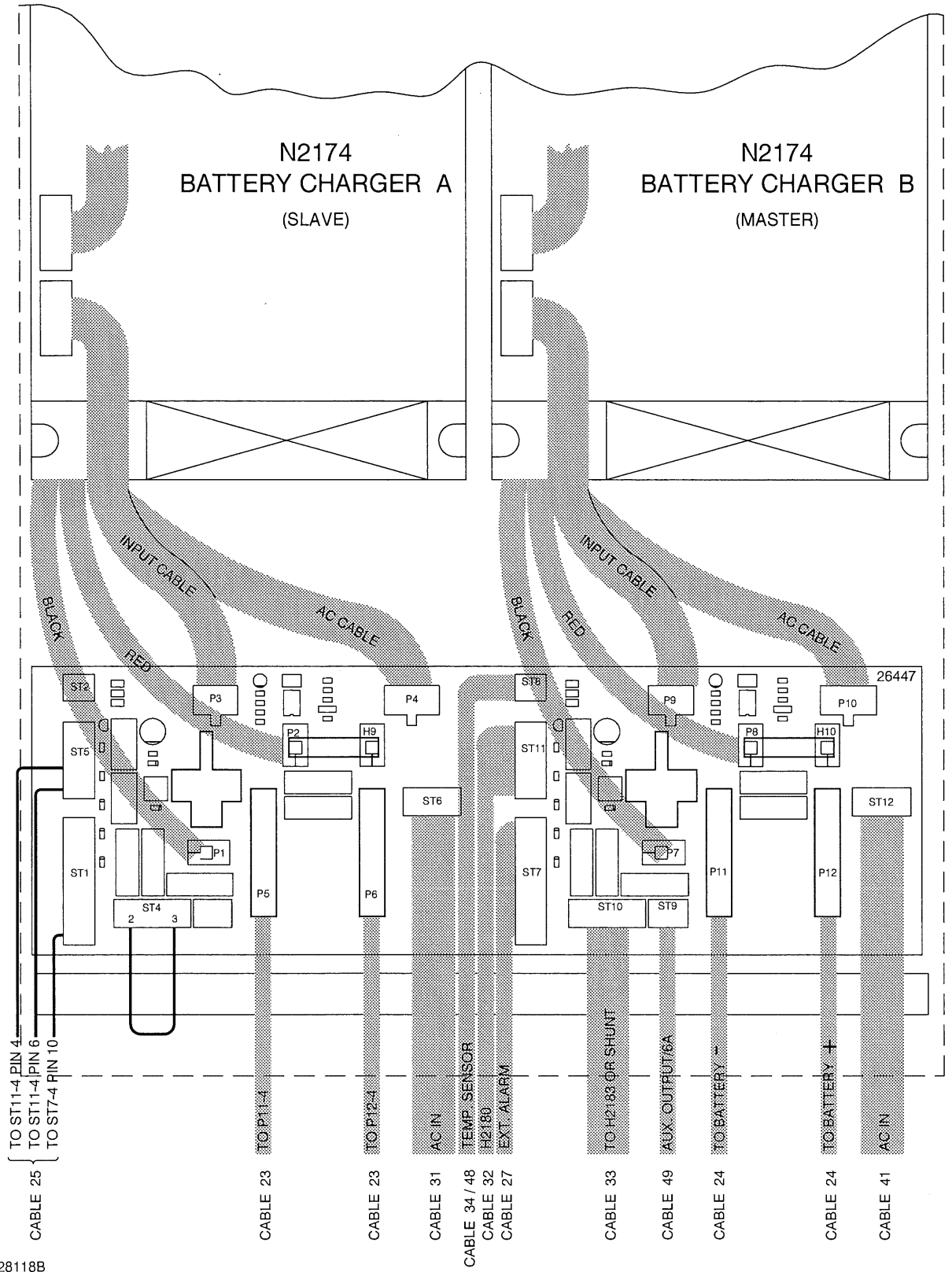

28118B

FOR CABLE DIMENSIONS: SEE PART I

CONNECTION TO 2 X N2174

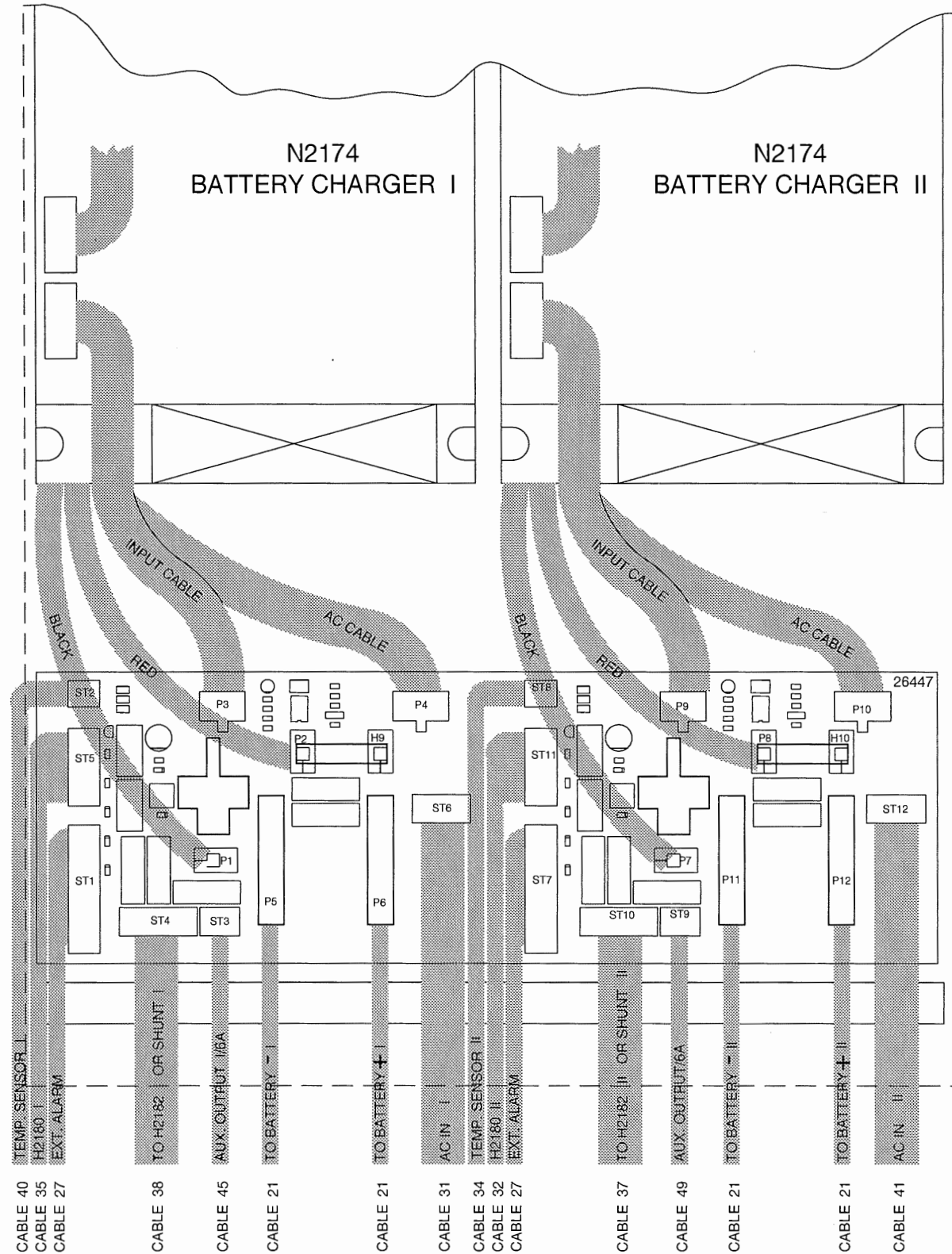

28119B

FOR CABLE DIMENSIONS: SEE PART I

CONTENTS

3	SERVICE	
3.1	MAINTENANCE	3-1
3.1.1	ADJUSTMENT TO CHARGE NICKEL CADMIUM BATTERIES	3-1
3.2	RECOMMENDED TEST EQUIPMENT	3-1
3.3	TROUBLE SHOOTING	3-1
3.4	PERFORMANCE CHECK FOR CHARGING LEAD-ACID BATTERIES	3-2
3.4.1	PERFORMANCE CHECK OF MANUAL CHARGE MODE (Lead-Acid)	3-2
3.4.2	PERFORMANCE CHECK OF AUTOMATIC CHARGE MODE (Lead-Acid)	3-2
3.5	NECESSARY CHECK AND ADJUSTMENT AFTER REPAIR (Lead-Acid)	3-3
3.6	PERFORMANCE CHECK FOR CHARGING NICKEL CADMIUM BATTERIES	3-4
3.6.1	PERFORMANCE CHECK OF MANUAL CHARGE MODE (NiCd)	3-4
3.6.2	PERFORMANCE CHECK OF AUTOMATIC CHARGE MODE (NiCd)	3-5
3.7	NECESSARY CHECK AND ADJUSTMENT AFTER REPAIR (NiCd)	3-6

3 SERVICE

3.1 MAINTENANCE

When the SAILOR N2174 has been correctly installed, the maintenance of the charger can, dependent on the environments and working hours, be reduced to a performance check at the service workshop at intervals not exceeding 5 years.

A performance check list is enclosed in the section 3.4 PERFORMANCE CHECK for charging Lead-Acid batteries and in the section 3.6 PERFORMANCE CHECK for charging Nickel Cadmium batteries.

Also inspect cables and plugs for mechanical defects and corrosion.

Any repair of the set should be followed by a check described in the section 3.5 NECESSARY ADJUSTMENT AND CHECK AFTER REPAIR (Lead-Acid) or 3.7 NECESSARY ADJUSTMENT AND CHECK AFTER REPAIR (NiCd)

3.1.1 ADJUSTMENT TO CHARGE NICKEL CADMIUM BATTERIES

See section 3.7 NECESSARY ADJUSTMENT AND CHECK AFTER REPAIR (NiCd).

3.2 RECOMMENDED TEST EQUIPMENT

OSCILLOSCOPE:

Bandwidth	DC-35 MHz
Sensitivity	2mV/div
Input Impedance	1 M ohm/20pF
E.g. Philips type	PM3216

MULTIMETER:

Input Impedance	10 M ohm
Accuracy DC (full scale deflection)	1.5%
E.g. Philips type	PM2505

3.3 TROUBLE SHOOTING

Trouble shooting, repair and check of the N2174 should only be performed by persons, who have sufficient technical knowledge and the necessary test equipment at their disposal.

To do some service of the SCR rectifier bridge, the blower frame can be turned upwards and placed in a service position (see chapter 4.1. MECHANICAL DISASSEMBLING AND MODULE LOCATION.) When placed in service position, AC mains power may be connected and the N2174 can work normally even with full load, but keep in mind to keep the fingers away from the blower. It can suddenly start up due to temperature rise of the rectifier bridge heatsink.

1. The battery is gassing:
 - a) The charging current is too high for the battery type.
 - b) The **upper level** voltage is too high.
 - c) The **trickle charge** voltage is too high.
 - d) N2174 is strapped for wrong battery type.
 - e) The battery is defective.
2. N2174 can not switch on in MANUAL mode.
 - a) Fuse F1-5 or F2-5 is blown out.
 - b) Blower circuit is out of order.
 - c) Temperature on the SCR heatsink is too high (maybe blower failure).
3. N2174 can not switch on in AUTOMATIC mode.
 - a) Fuse F1-5 or F2-5 is blown out.
 - b) Blower circuit is out of order.
 - c) Temperature on the SCR heatsink is too high (maybe blower failure).
 - d) The output is short circuited.
 - e) The battery voltage is below 7.5V.

3.4 PERFORMANCE CHECK FOR CHARGING LEAD-ACID BATTERIES

To handle the performance check in an easy way, it is recommended to connect the N2174 to a disconnected connection board (module 3 or module 4) used for the charger.

Any value, which differs too much from the values given in this chapter, should lead to a repair of the circuit or module in question.

Hints to locate some faults are given in the chapter 3.3 TROUBLE SHOOTING.

The given values in this chapter is basically for **24V maintenance free lead-acid batteries**.

If the battery temperature sensor is connected, the values are only valid if the battery temperature is 25° degree centigrade.

3.4.1 PERFORMANCE CHECK OF MANUAL CHARGE MODE (Lead-Acid)

1. Connect the N2174 to the charger connection board (module 3 or module 4).
2. Connect the N2174 to the AC mains, which it is strapped for. See 5.3 MAIN SCHEMATIC DIAGRAM. Normally the N2174 is strapped for 220V AC.
3. Connect a small dummy load to the output. A resistor of 27 ohm/50W is sufficient to get a proper regulation.
4. On the connection boards are placed three positions for a strap. These positions are marked REMOTE, AUTO and MAN. Normally the strap is placed in REMOTE position. Now, move the strap to MAN position and the N2174 is switched on in MANUAL charge mode. The output voltage is fluctuating, but that is normal because the battery is missing.
5. With a voltmeter across the output, read the voltage to 27.5VDC \pm 0.5V.
6. Connect a new dummy load of 0.77 ohm/900W to the output. It can be made by paralleling several power resistors.
7. Read the output voltage to 23VDC \pm 2V. The output current is 30A \pm 3A.
In case of no dummy load is available the charger can be connected to a slightly discharged battery through an amperemeter and then read the current to 30A \pm 3A.
8. Let it run with full load and check that the blower switches on after a while.
Normally it switches on within 6 minutes - depending on the temperature of the heatsink.
9. Move the strap on the connection board back to REMOTE position.

3.4.2 PERFORMANCE CHECK OF AUTOMATIC CHARGE MODE (Lead-Acid)

1. Connect the N2174 to the charger connection board (module 3 or module 4).
2. Connect the N2174 to the AC mains, which it is strapped for. See 5.3 MAIN SCHEMATIC DIAGRAM. Normally the N2174 is strapped for 220V AC.
3. Connect a small dummy load to the output. A resistor of 27 ohm/50W is sufficient to get a proper regulation.
4. The remote voltage sense terminals called +VS and -VS must be connected to the dummy load.
5. On the AUTOMATIC module check that a strap is placed in P5 in **MS** position, and also check a strap is placed in P3 in **TS-OFF** position. If the temperature sensor is connected the strap is placed in **TS-ON** position.
6. On the connection boards are placed three positions for a strap. These positions are marked REMOTE, AUTO and MAN. Normally the strap is placed in REMOTE position. Now move the strap to AUTO position.

7. With a voltmeter across the output, read the voltage to 0V. The N2174 is not switched on, because the battery is missing.
8. Connect to the output a small power supply capable of delivering 1.5A and adjustable up to 32V.
9. The small power supply is set to a voltage not less than 7.5V. Then the N2174 is switched on and the small power supply can be disconnected.
10. At first the output voltage is approx. 34VDC, but after approx. 10 seconds the voltage falls down to $27.3V \pm 0.2V$. This is the **trickle charge** voltage.
11. On the connection board move the strap back to REMOTE position. The N2174 is now switched off.
12. Connect again the small power supply to the output and set it to 24.0V.
13. The AUTOMATIC module is now in **charge** mode. All LED on the module is alight. After approx. 10 seconds the LED D31-2 (marked TRICKLE) is off.
14. Turn up slowly the voltage from the small power supply until D31-2 (marked TRICKLE) turns on and then read the voltage to $28.8VDC \pm 0.2V$. This is the **upper level shift** and the N2174 is now in **trickle charge** mode.
15. Turn back the voltage from the small power supply until D30-2 (marked CHARGE) turns on and read the voltage to $25.8VDC \pm 0.2V$. This is the **lower level shift** and the N2174 is now in **charge** mode.
16. Connect again the small power supply to the output and set it for a voltage over 7.5V to cancel the fault-stop circuit.
17. On the connection board now move the strap to AUTO to switch on the N2174.
18. While running, connect to the output a new dummy load of 0.77 ohm/900W and read the output voltage to $23VDC \pm 1V$. The output current is $30A \pm 3A$.
In case of no dummy load is available the charger can be connected to a slightly discharged battery through an amperemeter and then read the current to $30A \pm 3A$.
19. Connect an oscilloscope to the output and read the ripple voltage to max. $3V_{pp}$.
20. Let it run with full load and check that the blower switches on after a while. Normally it switches on within 6 minutes - depending on the temperature of the heatsink.
21. **Remember** to move back the strap to REMOTE position on the connection board.
22. An other way to start up the N2174 in AUTOMATIC charge mode while connected to a dummy load, is to short circuit R15-2 a short moment to cancel the fault-stop circuit.

3.5 NECESSARY CHECK AND ADJUSTMENT AFTER REPAIR (Lead-Acid)

CHANGE OR REPAIR OF THE MANUAL CONTROL (module 1).

Execute chapter 3.4.1. **PERFORMANCE CHECK OF MANUAL CHARGE MODE.**
Adjust if necessary the output voltage to $27.5VDC \pm 0.2V$ with R4-1.

Execute chapter 3.4.2. **PERFORMANCE CHECK OF AUTOMATIC CHARGE MODE.**
Adjust if necessary the output voltage to $23.0VDC \pm 0.2V$ with R60-2. (Current limiter for $30A \pm 1A$).

CHANGE OR REPAIR OF THE AUTOMATIC CONTROL (module 2).

Execute chapter 3.4.2. **PERFORMANCE CHECK OF AUTOMATIC CHARGE MODE.**

Adjust if necessary the *trickle* voltage to $27.3\text{VDC} \pm 0.1\text{V}$ with R39-2.

Adjust if necessary the *upper level* voltage to $28.8\text{VDC} \pm 0.1\text{V}$ with R63-2.

This adjustment is done by turning R63-2 full clockwise. Then connect the small dummy load, and set the small power supply for 28.8VDC which turns on the LED D30-2 (marked CHARGE). Turn slowly R63-2 counter clockwise just until the LED D31-2 (marked TRICKLE) turns on.

Adjust if necessary the output voltage to $23.0\text{VDC} \pm 0.2\text{V}$ with R60-2. (Current limiter for $30\text{A} \pm 1\text{A}$).

3.6 PERFORMANCE CHECK FOR CHARGING NICKEL CADMIUM BATTERIES

To handle the performance check in an easy way, it is recommended to connect the N2174 to a disconnected connection board (module 3 or module 4) used for the charger.

Any value, which differs too much from the values given in this chapter, should lead to a repair of the circuit or module in question.

Hints to locate some faults are given in the chapter 3.3 TROUBLE SHOOTING.

The given values in this chapter is only valid for charging a **20 cells Nickel-Cadmium (NiCd)** battery.

3.6.1 PERFORMANCE CHECK OF MANUAL CHARGE MODE (NiCd)

1. Connect the N2174 to the charger connection board (module 3 or module 4).
2. Connect the N2174 to the AC mains, which it is strapped for. See 5.3 MAIN SCHEMATIC DIAGRAM. Normally the N2174 is strapped for 220V AC.
3. Connect a small dummy load to the output. A resistor of 27 ohm/50W is sufficient to get a proper regulation.
4. On the connection boards are placed three positions for a strap. These positions are marked REMOTE, AUTO and MAN. Normally the strap is placed in REMOTE position. Now move the strap to MAN position and the N2174 is switched on in MANUAL charge mode. The output voltage is fluctuating, but that is normal because the battery is missing.
5. With a voltmeter across the output, read the voltage to $28.5\text{VDC} \pm 0.5\text{V}$.
6. Connect a new dummy load of 0.77 ohm/900W to the output. It can be made by paralleling several power resistors.
7. Read the output voltage to $23\text{VDC} \pm 2\text{V}$. The output current is $30\text{A} \pm 3\text{A}$. In case of no dummyload is available the charger can be connected to a slightly discharged battery through an amperemeter and then read the current to $30\text{A} \pm 3\text{A}$.
8. Let it run with full load and check that the blower switches on after a while. Normally it switches on within 6 minutes - depending on the temperature of the heatsink.
9. Move the strap on the connection board back to REMOTE position.

3.6.2 PERFORMANCE CHECK OF AUTOMATIC CHARGE MODE (NiCd)

1. Connect the N2174 to the charger connection board (module 3 or module 4).
2. Connect the N2174 to the AC mains, which it is strapped for. See 5.3 MAIN SCHEMATIC DIAGRAM. Normally the N2174 is strapped for 220V AC.
3. Connect a small dummy load to the output. A resistor of 27 ohm/50W is sufficient to get a proper regulation.
4. The remote voltage sense terminals called +VS and -VS must be connected to the dummy load.
5. On the AUTOMATIC module check that a strap is placed in P5 in **MS** position, and also check a strap is placed in P3 in **NiCd** position.
6. On the connection boards are placed three positions for a strap. These positions are marked REMOTE, AUTO and MAN. Normally the strap is placed in REMOTE position. Now move the strap to AUTO position.
7. With a voltmeter across the output, read the voltage to 0V. The N2174 is not switched on, because the battery is missing.
8. Connect to the output a small power supply capable of delivering 1.5A and adjustable up to 32V.
9. The small power supply is set to a voltage not less than 7.5V. Then the N2174 is switched on and the small power supply can be disconnected.
10. At first the output voltage is approx. 34VDC, but after 10 seconds the voltage falls down to $28.4V \pm 0.2V$. This is the **trickle charge** voltage.
11. On the connection board move the strap back to REMOTE position. The N2174 is now switched off.
12. Connect again the small power supply to the output and set it to 24.0V.
13. The AUTOMATIC module is now in **charge** mode. All LED on the module is alight. After approx. 10 seconds the LED D31-2 (marked TRICKLE) is off.
14. Turn up slowly the voltage from the small power supply until D31-2 (marked TRICKLE) turns on and then read the voltage to $30.5VDC \pm 0.2V$. This is the **upper level shift** and the N2174 is now in **trickle charge** mode.
15. Turn back the voltage from the small power supply until D30-2 (marked CHARGE) turns on and read the voltage to $27.5VDC \pm 0.3V$. This is the **lower level shift** and the N2174 is now in **charge** mode.
16. Connect again the small power supply to the output and set it for a voltage over 7.5V to cancel the fault-stop circuit.
17. On the connection board now move the strap to AUTO to switch on the N2174.
18. While running, connect to the output a new dummy load of 0.77 ohm/900W and read the output voltage to $23VDC \pm 1V$. The output current is $30A \pm 3A$.
In case of no dummy load is available the charger can be connected to a slightly discharged battery through an amperemeter and then read the current to $30A \pm 3A$.
19. Connect an oscilloscope to the output and read the ripple voltage to max. $3V_{pp}$.
20. Let it run with full load and check that the blower switches on after a while. Normally it switches on within 6 minutes - depending on the temperature of the heatsink.
21. **Remember** to move back the strap to REMOTE position on the connection board.
22. An other way to start up the N2174 in AUTOMATIC charge mode while connected to a dummy load, is to short circuit R15-2 a short moment to cancel the fault-stop circuit.

3.7 NECESSARY CHECK AND ADJUSTMENT AFTER REPAIR (NiCd)

CHANGE OR REPAIR OF THE MANUAL CONTROL (module 1).

Execute chapter 3.6.1. **PERFORMANCE CHECK OF MANUAL CHARGE MODE.**

Adjust if necessary the output voltage to $28.5\text{VDC} \pm 0.2\text{V}$ with R4-1.

Execute chapter 3.6.2. **PERFORMANCE CHECK OF AUTOMATIC CHARGE MODE.**

Adjust if necessary the output voltage to $23.0\text{VDC} \pm 0.2\text{V}$ with R60-2. (Current limiter for $30\text{A} \pm 1\text{A}$).

CHANGE OR REPAIR OF THE AUTOMATIC CONTROL (module 2).

Execute chapter 3.6.2. **PERFORMANCE CHECK OF AUTOMATIC CHARGE MODE.**

Adjust if necessary the *trickle* voltage to $28.4\text{VDC} \pm 0.1\text{V}$ with R39-2.

Adjust if necessary the *upper level* voltage to $30.5\text{VDC} \pm 0.1\text{V}$ with R63-2.

This adjustment is done by turning R63-2 full clockwise. Then connect the small dummy load, and set the small power supply for $30.5\text{VDC} \pm 0.1\text{V}$ which turns on the LED D30-2 (marked CHARGE). Turn slowly R63-2 counter clockwise just until the LED D31-2 (marked TRICKLE) turns on.

Adjust if necessary the output voltage to $23.0\text{VDC} \pm 0.1\text{V}$ with R60-2. (Current limiter for $30\text{A} \pm 1\text{A}$).

CONTENTS

4	MECHANICAL DESCRIPTION	4-1
4.1	MECHANICAL ASSEMBLING / DISASSEMBLING AND UNITS LOCATION	4-1

4 MECHANICAL DESCRIPTION

4.1 MECHANICAL ASSEMBLING / DISASSEMBLING AND UNITS LOCATION

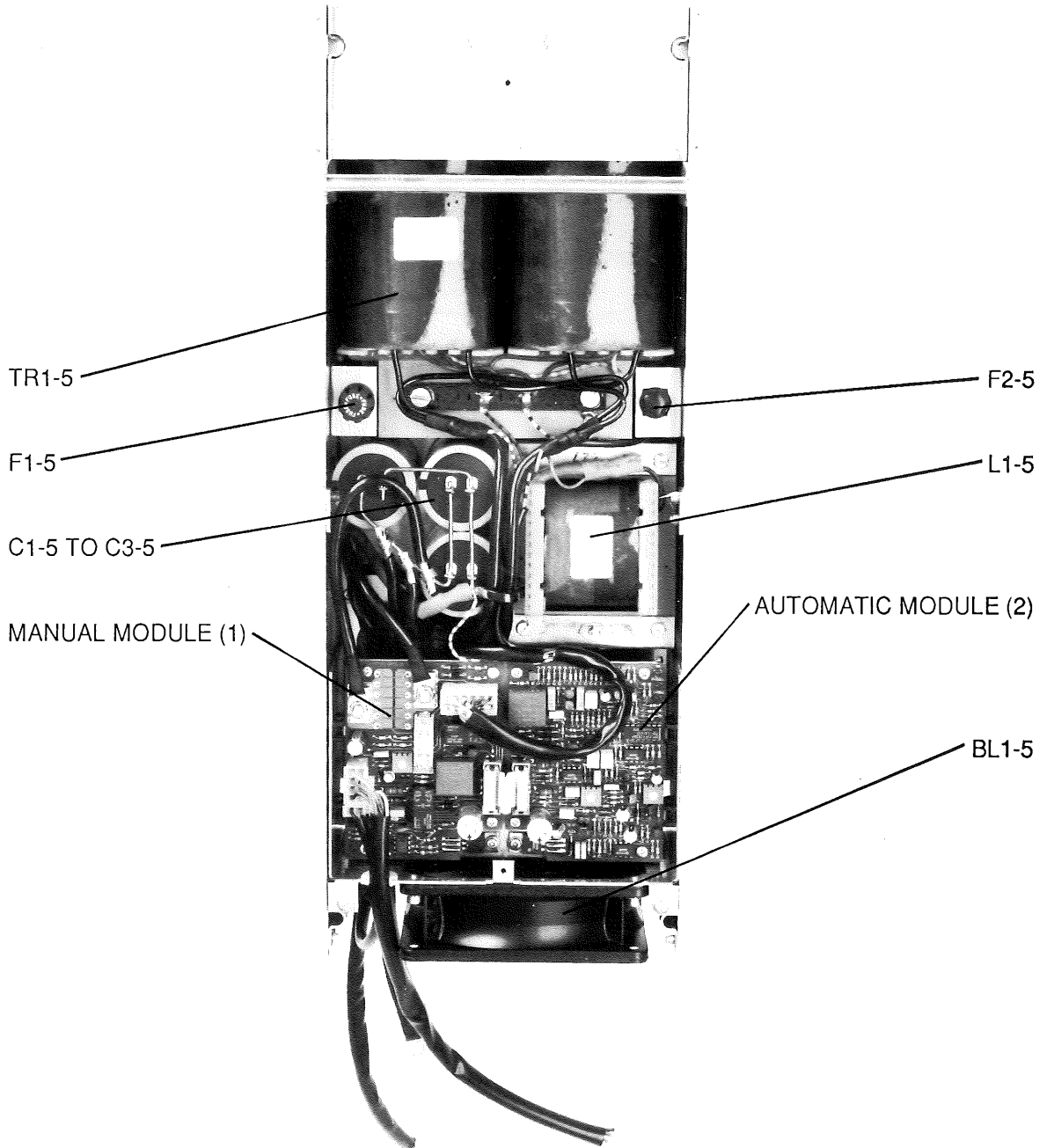

501298

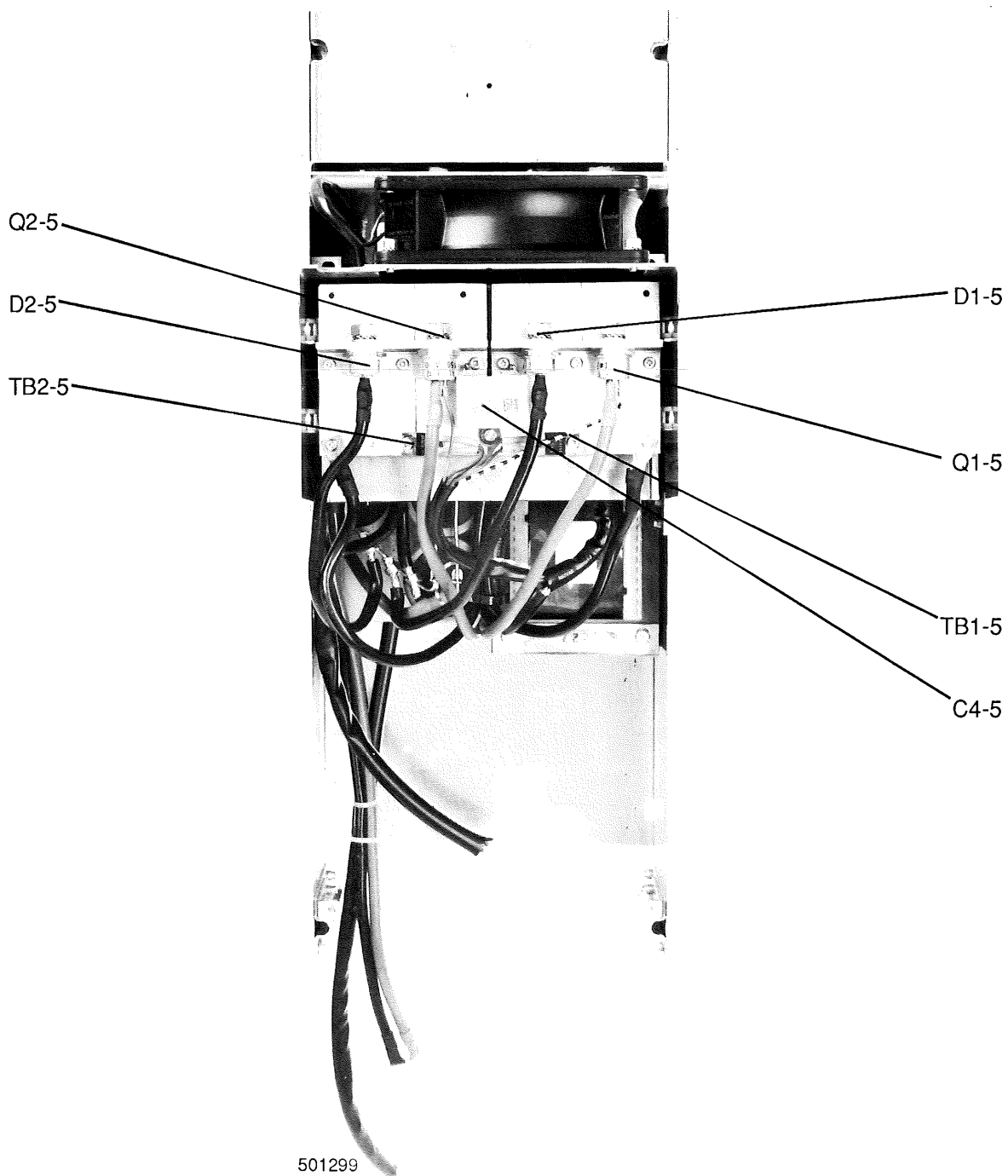

CONTENTS

5	CIRCUIT DESCRIPTION AND SCHEMATIC DIAGRAMS	
5.1	MANUAL CONTROL (MODULE 1) PART NO. 626444	5-1
5.2	AUTOMATIC CONTROL (MODULE 2) PART NO. 626445	5-5
5.3	MAIN SCHEMATIC DIAGRAM N2174	5-10

5 CIRCUIT DESCRIPTION AND SCHEMATIC DIAGRAMS

5.1 MANUAL CONTROL (MODULE 1) PART NO. 626444

TRIGGER PULSE OSCILLATOR

This module also serves as an internal connection board, where all the cables inside N2174 are connected. The charger can work only with the MANUAL module present. If the AUTOMATIC module is out of order, it can be removed for repair while the charger is working in MANUAL mode. However, this mode is not recommended for long term charging, because of the simplified regulation of the output voltage to the battery.

In MANUAL mode the SCR's are triggered by a line synchronised relaxation oscillator performed by the unijunction transistor Q2. To synchronise the circuit to the line frequency, the circuit is connected to the 46V AC output from the transformer TR1-5.

When the output voltage comes over the reference voltage from D4, the transistor Q1 is switching off the oscillator and the SCR's are shut down until the output voltage again is falling. This maximum output voltage, which is depending on battery type, is adjusted with R4.

The output current runs through the resistors R24 to R29 and generates a voltage, which also shuts down the oscillator by Q5 when the current exceeds approx. 30A.

The change over from MANUAL mode to AUTOMATIC mode is done by the relay RE2.

To switch off the MANUAL charge mode the relay RE1 is switched off by a remote switch.

BLOWER CIRCUIT

The blower is supplied by approx. 27VDC. This voltage is taken from the 46V AC transformer output and is rectified by D1 and D2. The FET Q3 is connected as a ripple clipper and the clipping level is controlled by the shunt regulator D11 by means of R20 and R21.

To switch on the blower a thermal breaker TB1-5 is placed on the heatsink for the SCR's. This thermal breaker turns on Q4, which again turns on the blower.

The voltage from Q3 called 26V is also used to supply the relays RE1 and RE2 via remote switches to switch on the MANUAL mode or the AUTOMATIC mode. The 26V is led through a thermal breaker TB2-5, which switches off the supply for the relays if the temperature on the SCR heatsink exceeds 90° degree centigrade in case of blower failure. This will shut down the charger until the temperature again comes under approx. 70°.

COMPONENT LOCATION MANUAL CONTROL MODULE 1

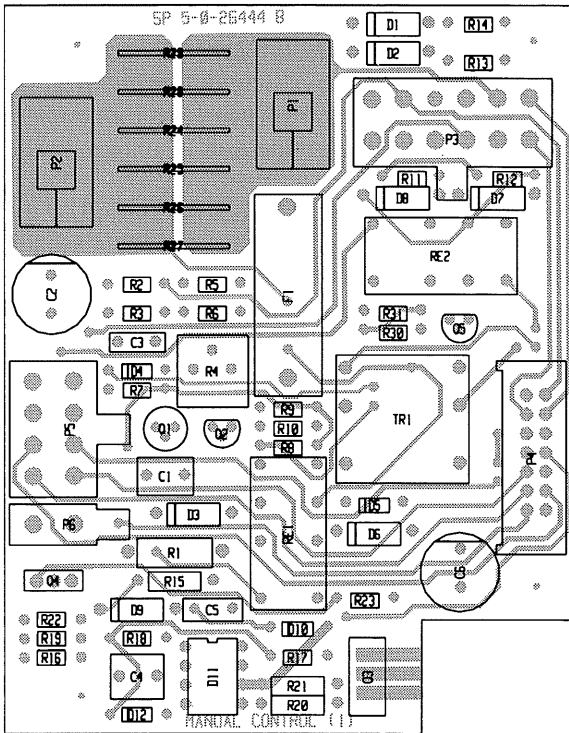

View from component side with upper side tracks.

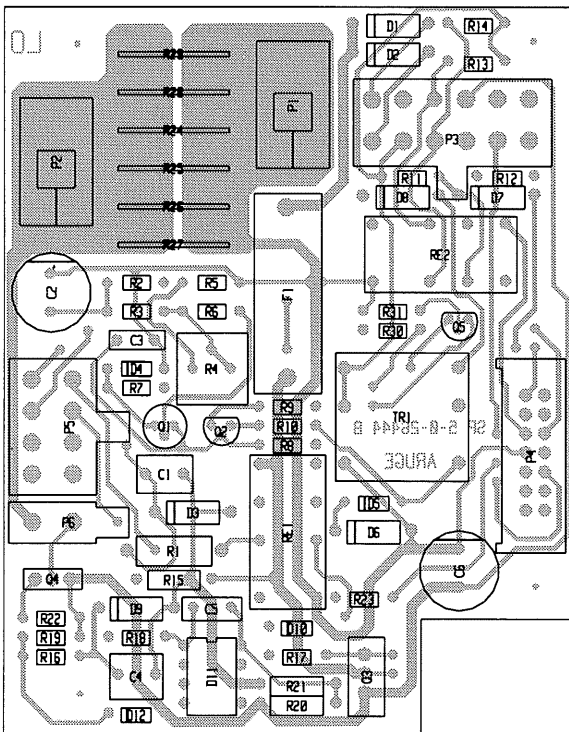

View from component side with lower side tracks.
PCB rev. 26444B

MANUAL CONTROL MODULE 1

Manual Control (1)

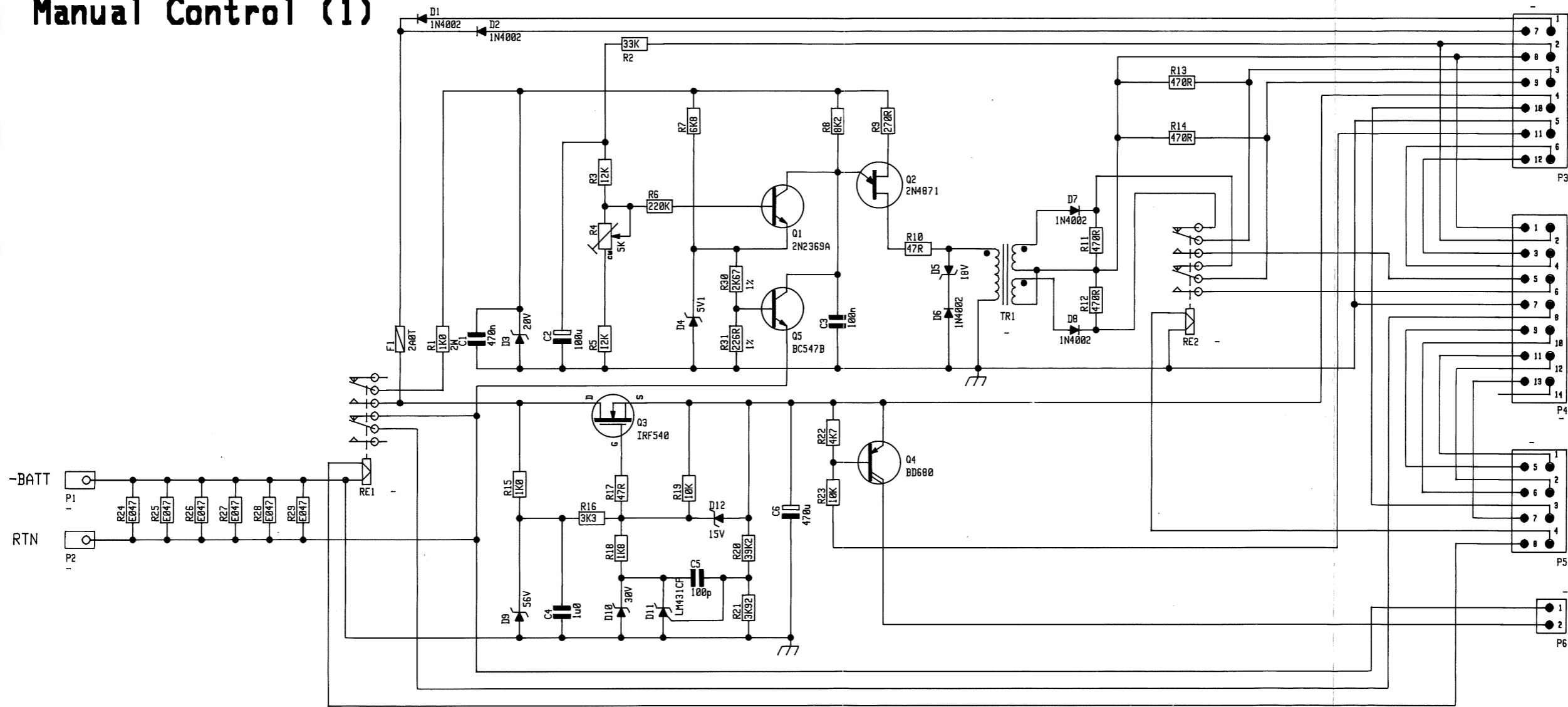

- PIN 1 46V AC
 PIN 2 +VB
 PIN 3 GT1
 PIN 4 TB2
 PIN 5 TB1
 PIN 6 22V AC
 PIN 7 46V AC
 PIN 8 CAT
 PIN 9 GT2
 PIN 10 26V, TB2
 PIN 11 BL. ON, TB1
 PIN 12 22V AC

TO AUTO MODULE

- PIN 1 CAT
 PIN 2 +VB
 PIN 3 22V AC
 PIN 4 22V AC
 PIN 5 GTA1
 PIN 6 GTA2
 PIN 7 +IS
 PIN 8 -IS
 PIN 9 +TS
 PIN 10 -TS
 PIN 11 +VS
 PIN 12 -VS
 PIN 13 M/S
 PIN 14

TO CONNECTION BOARD

- PIN 1 +VS
 PIN 2 -VS
 PIN 3 26V
 PIN 4 AUTO
 PIN 5 +TS
 PIN 6 -TS
 PIN 7 M/S
 PIN 8 MAN

TO BLOWER

- PIN 1 -BLOWER
 PIN 2 +BLOWER

4-0-26444A

4-0-26444A

5.2 AUTOMATIC CONTROL (MODULE 2) PART NO. 626445

CONTROLLED REFERENCE VOLTAGE VCR

The voltage regulator U1 produces a stable 15V supply for the on board circuits. To produce a reference voltage for the output voltage regulation, a circuit is build around U3. This circuit is highly stable but is also changeable according to the charger application, which is determined by placing a strap in P2.

Strap placed in P2 (TS-ON) means the temperature correction circuit around U2.1 is connected to the reference voltage regulator U3, which means the temperature sensor is connected to N2174. The reference voltage **VCR** will increase with decreasing temperature and visa versa. This causes the output *trickle* voltage and the *upper level* shift voltage to follow a temperature curve, which is characteristic of **lead-acid** batteries. The temperature coefficient of a 24V **lead-acid** battery is approx. -48 mV per degree centigrade. This temperature correction circuit may be used if the battery is placed in extreme temperature environment.

Strap placed in P3 (TS-OFF) means the temperature circuit is disconnected, but the charger is now in a **normal** condition for charging **maintenance free lead-acid** batteries.

Strap placed in P4 (NiCd) means that the output voltage is higher and therefor is able to charge batteries of the **Nickel-Cadmium** type. Depending on battery type the *trickle* voltage and the *upper level shift* voltage has to be adjusted. This is done by R39 and R63.

FAULT-STOP

If the temperature sensor placed at the battery is short circuited or if the battery voltage is below approx. 4V, the circuit around U2.2 will shut down the **automatic** charge mode until the fault is removed.

SYNCRONISED PULSE TRIGGER

The circuit consisting of Q3, Q4, D11, D12 and C8 generates a line synchronised ramp voltage. This ramp is compared with the DC level from the current limiter U5.2 or from the voltage regulation circuit U5.1. This comparison is done by U4.1, which generate a pulse width modulated signal to control the SCR trigger pulses created by the astable multivibrator of Q5 and Q6.

OUTPUT VOLTAGE REGULATION

The U4.2 is a buffer for the remote voltage sense wires, which senses the battery voltage at the battery in order to cancel voltage loss in the cable between the charger and the battery. This circuit is protected against accidentally wrong connection of the remote sense wires. The output signal of U4.2 is led to the fault stop circuit U2.2, to the level shift circuit and to the error amplifier U5.1. The error amplifier compares the battery voltage to the reference voltage VCR to create a signal to control the duty cycle of the SCR trigger pulses, which again regulates the output voltage and the current to the battery. When the charger is in the **trickle** charge mode, the transistor Q8 is ON, which gives a constant output voltage, which can be adjusted by R39.

When the charger is in **charge** mode the output voltage has to be higher to drive maximum current into the battery, this is done by turning off Q8. The state of Q8 is controlled by the level shift circuit around U7. This is called the **MASTER** configuration, where the strap of P5 is placed over pin 1 and pin 2 (MS position). If it is required to control the output voltage by an other N2174 charger unit working in parallel, the strap of P5 is placed over pin 2 and pin 3 (SL position). This is called the **SLAVE** configuration.

CURRENT LIMITER

The current sense resistors R24-1 to R29-1 for the current limiter circuit U5.2 are placed on the **manual control** (module 1). The reference voltage for the current limiter comes from D29 and is compared to the current sense voltage from module 1. The current limiter can be adjusted by means of R63.

LEVEL SHIFT CIRCUIT

The output from U4.2 is led to the voltage follower and filter U6.1. When the battery voltage is exceeding the *upper level*, determined by R63, the comparator U6.2 goes high. This causes the gates U7 to turn off Q9 and by R79 the Q8 is turned on in order to reduce the output voltage of the charger to *trickle charge* level. When the battery voltage goes under the *lower level*, the comparator U6.2 goes low, which again turns off the Q8 and the charger goes into *charge* mode and so on. The *lower level* is approx. 10% below the *upper level*. The gates U7 performs delay for the shifting time. When the charger has changed to one state, it stays there for 10 seconds before it can be changed back. This is to prevent transients to unstable the shifting from one state to the other.

The LED's is indicators to tell in what state the charger is working in. That might be useful when adjusting the *level shift* with R63. When in *charge* mode the D30 (marked CHARGE) is ON and when in *trickle* mode the D31 (marked TRICKLE) is ON. The D32 (marked ON) indicates that AC mains power is on.

COMPONENT LOCATION AUTOMATIC CONTROL MODULE 2

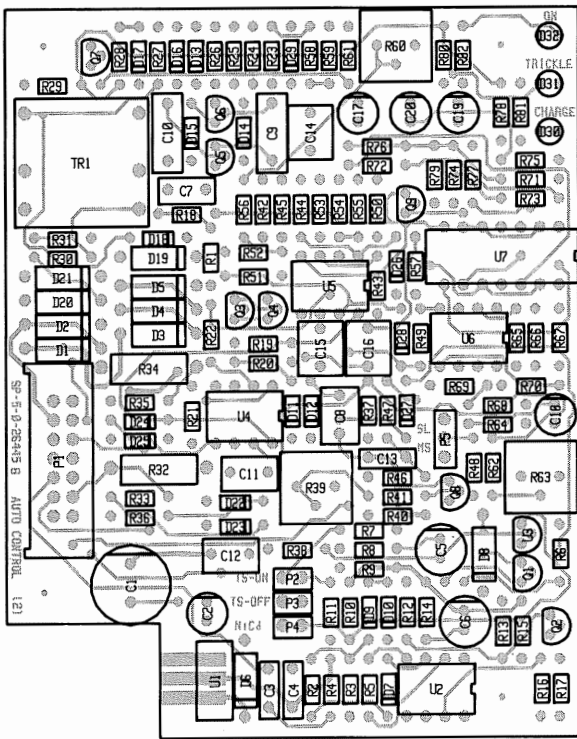

View from component side with upper side tracks.

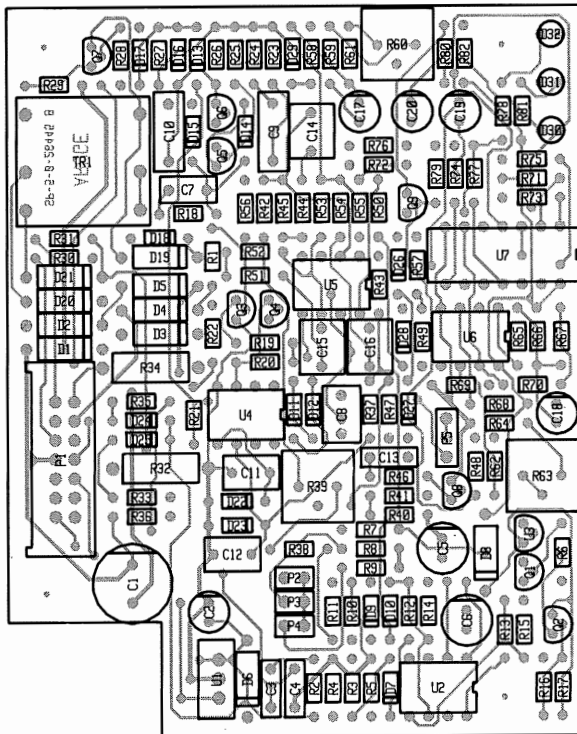

View from component side with lower side tracks.

5-0-26445B / 4-6-26445

AUTOMATIC CONTROL MODULE 2

Automatic Control (2)

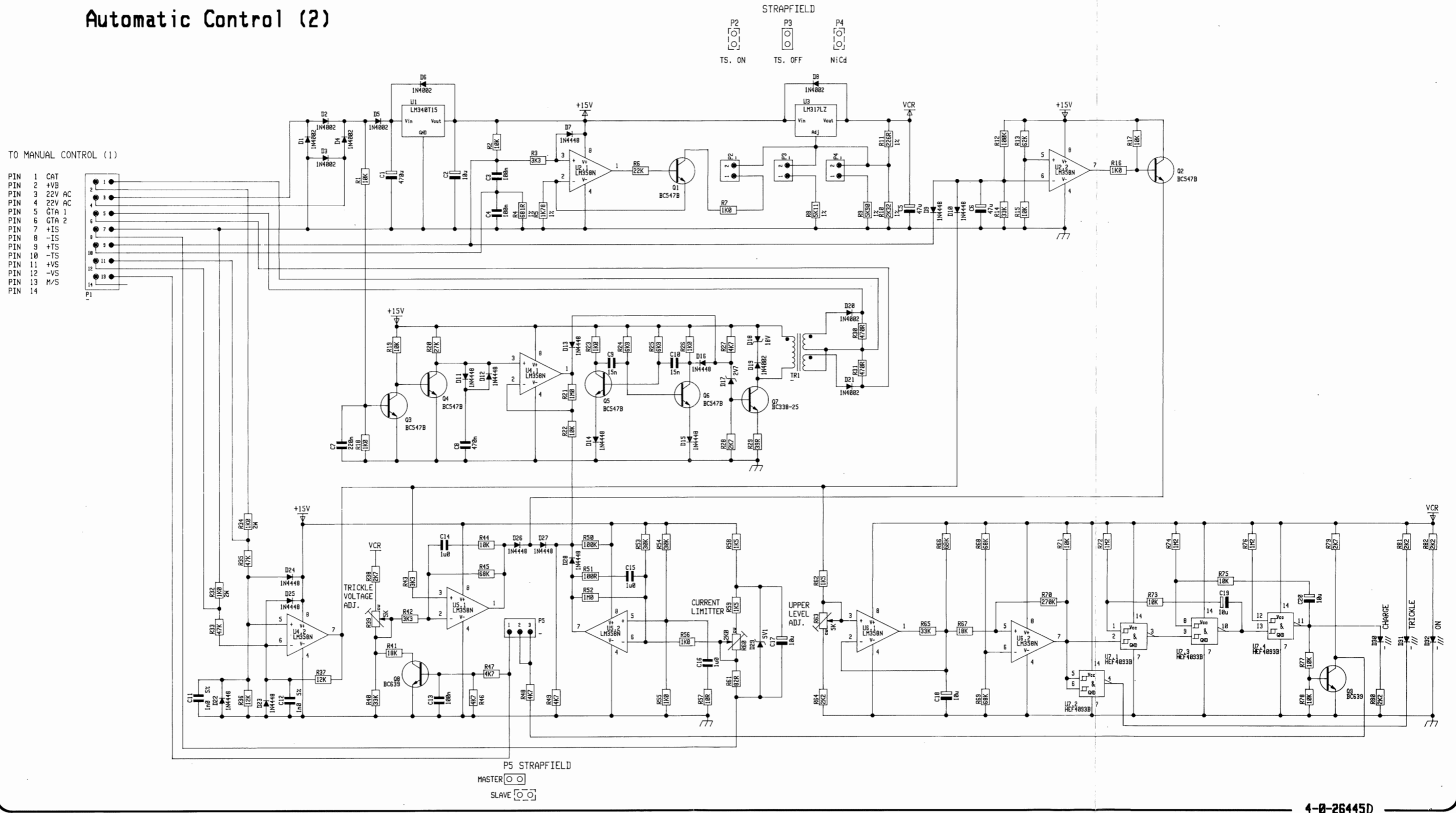

4-0-26445D

4-0-26445D

5.3 MAIN SCHEMATIC DIAGRAM N2174

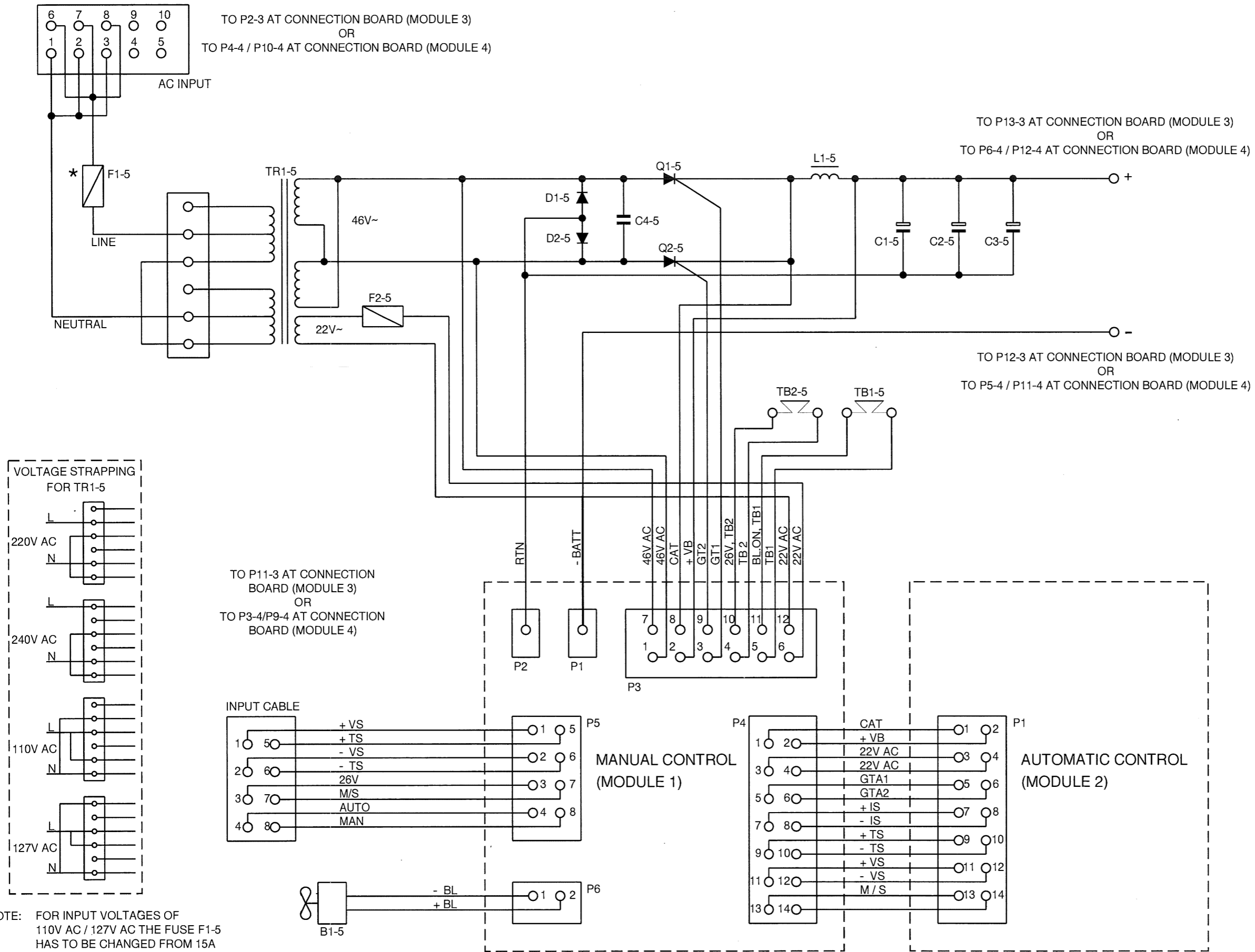

* NOTE: FOR INPUT VOLTAGES OF 110V AC / 127V AC THE FUSE F1-5 HAS TO BE CHANGED FROM 15A TO 25A (S.P. NUMBER 45.632)

CONTENTS

6 PARTS LISTS

6-1

GRØN SIDE

6 PARTS LISTS

BATTERY CHARGER UNIT 600W		HF SSB PROGRAMME	ECI A/S	0-0-26440	726440
POSITION	DESCRIPTION		MANUFACTOR	TYPE	PART NO.
VARIOUS	AC SUPPLY CABLE N2171/600		ECI A/S	3-0-26515	526515
VARIOUS	BLOWER CABLE N2171/600W		ECI A/S	3-0-26516	526516
VARIOUS	INPUT CABLE N2174		ECI A/S	0-0-28011	528011
VARIOUS	PILOT WIRE N2174		ECI A/S	0-0-28012	528012
VARIOUS	INTERCONNECTION CABLE	14 POLES L=45mm	3M	3-0-26082A	56.020
VARIOUS	1 POLE FUSEHOLDER	342.014	WICKMANN	342.014	78.393
VARIOUS	1 POLE FUSEHOLDER	FEP031 1001	SHURTER	FEP031 1001	78.423
-1	MANUAL CONTROL (MODULE 1)	N2174	ECI A/S	5-0-26444C 4-0-26444B	626444
-2	AUTO CONTROL (MODULE 2)	N2174	ECI A/S	5-0-26445B / 4-0-26445D	626445
BL1-5	FAN 24VDC	119x119x38mm	PAPST	4124 KX	60.100
C1-5	CAPACITOR ELECTROLYTIC	10000uF -10/+50% 63VDC	PHILIPS	2222 050 68103 & 4322 043 05581 & 4322 043 05561	14.870
C2-5	CAPACITOR ELECTROLYTIC	10000uF -10/+50% 63VDC	PHILIPS	2222 050 68103 & 4322 043 05581 & 4322 043 05561	14.870
C3-5	CAPACITOR ELECTROLYTIC	10000uF -10/+50% 63VDC	PHILIPS	2222 050 68103 & 4322 043 05581 & 4322 043 05561	14.870
C4-5	CAPACITOR MKT	6u8F 10% 100VDC	PHILIPS	2222 373 21685	11.084
D1-5	DIODE RECTIFIER DO-5	200V/70ADC 70HF20	INT.RECTIFIER	70HF20 (30,40,—,160)	25.166
D2-5	DIODE RECTIFIER DO-5	200V/70ADC 70HF20	INT.RECTIFIER	70HF20 (30,40,—,160)	25.166
F1-5	FUSE	15AM Ø6.3x32mm	LITTELFUSE	311015	45.630
F2-5	FUSE	5x20mm 500mA M 250V	WICKMANN *	19201-RP480514	45.513
L1-5	CHOKE FIXED	2mH/30A 50Hz	KOHSEL	96/58-SP5	20.257
Q1-5	SCR 200Vp/63Arms	DO-65 50RIA20/BTW50-200	INT.RECTIFIER	50RIA20(40,60,80,100,120)	29.940
Q2-5	SCR 200Vp/63Arms	DO-65 50RIA20/BTW50-200	INT.RECTIFIER	50RIA20(40,60,80,100,120)	29.940
TB1-5	THERMAL BREAKER	ON: 70 centigrade	AIRPAX	67F070	44.056
TB2-5	THERMAL BREAKER	OFF: 90 centigrade	AIRPAX	67L090	44.075
TR1-5	TRANSFORMER MAINS	1k3VA N2174	KOHSEL	U1120/60-SP11	22.188

MANUAL CONTROL (MODULE 1)		N2174	ECI A/S	5-0-26444C 4-0-26444B	626444
POSITION	DESCRIPTION		MANUFACTOR	TYPE	PART NO.
				626444-CB	
C1-1	CAPACITOR MKT	470nF 20% 63VDC	ERO	MKT 1826-447/06 6-G	11.188
C2-1	CAPACITOR ELECTROLYTIC	100uF -20/+50% 63VDC	ELNA	RJ2-63-V-101-M-F	14.620
C3-1	CAPACITOR MKT	100nF 5% 63VDC	PHILIPS	2222 370 79104	11.135
C4-1	CAPACITOR MKT	1uF 5% 63VDC	ERO	MKT 1826-510/06 4-G	11.190
C5-1	CAPACITOR CERAMIC	100pF 5% NPO 50VDC	KCK	RT-HE80 SK CH 101 J	15.136
C6-1	CAPACITOR ELECTROLYTIC	470uF -20/+50% 40VDC	ELNA	RJ3-50-471-M-F	14.649
D1-1	DIODE RECTIFIER	1N4002 100V/1A	THOMSON	1N4002 (03/04/05/06/07)	25.100
D2-1	DIODE RECTIFIER	1N4002 100V/1A	THOMSON	1N4002 (03/04/05/06/07)	25.100
D3-1	DIODE ZENER	20V 5%	THOMSON-CSF	BZV47C20	26.772
D4-1	DIODE ZENER	5.1V 5% 0.4W BZX79C5V1	PHILIPS	BZX79C5V1	26.527
D5-1	DIODE ZENER	18V 5% 0.4W BZX79C18	PHILIPS	BZX79C18	26.564
D6-1	DIODE RECTIFIER	1N4002 100V/1A	THOMSON	1N4002 (03/04/05/06/07)	25.100
D7-1	DIODE RECTIFIER	1N4002 100V/1A	THOMSON	1N4002 (03/04/05/06/07)	25.100
D8-1	DIODE RECTIFIER	1N4002 100V/1A	THOMSON	1N4002 (03/04/05/06/07)	25.100
D9-1	DIODE ZENER	56V 5%	THOMSON-CSF	BZV47C56	26.788
D10-1	DIODE ZENER	30V 5% 0.4W BZX79C30	PHILIPS	BZX79C30	26.578
D11-1	DIODE SHUNT REGULATOR	PROGRAMMABLE TL431C	TEXAS	TL431CP	26.997
D12-1	DIODE ZENER	15V 5% 0.4W BZX79C15	PHILIPS	BZX79C15	26.561
F1-1	FUSE	2AT 250V 5x20mm	WICKMANN	19 195 2AT	45.508
P1-1	CONNECTION ELEMENT	FOR M5 SCREW	ECI A/S	1-0-25860	225860
P2-1	CONNECTION ELEMENT	FOR M5 SCREW	ECI A/S	1-0-25860	225860
P3-1	MULTIPLUG	2x6 POLES PCB VERSION	MOLEX	39-28-1123	78.221
P4-1	PLUG	2x7 POLES	3M	3598-6002 / 7614-6002 JL	78.254
P5-1	MULTIPLUG	2x4 POLES PCB VERSION	MOLEX	39-28-1083	78.218
P6-1	PLUG 2POLES		MOLEX	39-28-1023	78.215
Q1-1	TRANSISTOR RF SWITCH	2N2369A	MOTOROLA	2N2369A	28.315
Q2-1	TRANSISTOR UNIJUNCTION	2N4871	MOTOROLA	2N4871	29.810
Q3-1	TRANS.POV.MOSFET N-CHANN.	100V/27A/85mOHM IRF540	MOTOROLA	IRF540	29.402
Q4-1	TRANSISTOR	BD680	PHILIPS*	BDX47	29.338
Q5-1	TRANSISTOR AF	BC547B NPN TO-92	PHILIPS	BC547B	28.067
R1-1	RESISTOR PMF	1k0 OHM 5% 2W	PHILIPS	2322 194 13102	04.200

POSITION	DESCRIPTION		MANUFACTURER	TYPE	PART NO.
R2-1	RESISTOR MF	33k OHM 5% 0.33W	PHILIPS	2322 187 73333	02.508
R3-1	RESISTOR MF	12k OHM 5% 0.33W	PHILIPS	2322 187 73123	02.498
R4-1	PRESET CERMET	5k0 OHM 10% 0.5W	BOURNS	3386P-1-502	07.888
R5-1	RESISTOR MF	12k OHM 5% 0.33W	PHILIPS	2322 187 73123	02.498
R6-1	RESISTOR MF	220k OHM 5% 0.33W	PHILIPS	2322 187 73224	02.528
R7-1	RESISTOR MF	6k8 OHM 5% 0.33W	PHILIPS	2322 187 73682	02.492
R8-1	RESISTOR MF	8k2 OHM 5% 0.33W	PHILIPS	2322 187 73822	02.494
R9-1	RESISTOR MF	270 OHM 5% 0.33W	PHILIPS	2322 187 73271	02.458
R10-1	RESISTOR MF	47 OHM 5% 0.33W	PHILIPS	2322 187 73479	02.440
R11-1	RESISTOR MF	470 OHM 5% 0.33W	PHILIPS	2322 187 73471	02.464
R12-1	RESISTOR MF	470 OHM 5% 0.33W	PHILIPS	2322 187 73471	02.464
R13-1	RESISTOR MF	470 OHM 5% 0.33W	PHILIPS	2322 187 73471	02.464
R14-1	RESISTOR MF	470 OHM 5% 0.33W	PHILIPS	2322 187 73471	02.464
R15-1	RESISTOR MF	1k0 OHM 5% 0.4W	PHILIPS	2322 181 53102	01.200
R16-1	RESISTOR MF	3k3 OHM 5% 0.33W	PHILIPS	2322 187 73332	02.484
R17-1	RESISTOR MF	47 OHM 5% 0.33W	PHILIPS	2322 187 73479	02.440
R18-1	RESISTOR MF	1k8 OHM 5% 0.33W	PHILIPS	2322 187 73182	02.478
R19-1	RESISTOR MF	10k OHM 5% 0.33W	PHILIPS	2322 187 73103	02.496
R20-1	RESISTOR MF	39k2 OHM 1% 0.6W	PHILIPS	2322 156 13923	03.439
R21-1	RESISTOR MF	3k92 OHM 1% 0.6W	PHILIPS	2322 156 13922	03.409
R22-1	RESISTOR MF	4k7 OHM 5% 0.33W	PHILIPS	2322 187 73472	02.488
R23-1	RESISTOR MF	10k OHM 5% 0.33W	PHILIPS	2322 187 73103	02.496
R24-1	RESISTOR	47m OHM 5% 0.6W	MODULOHM I/S	98247/47U-J-MI-A-1	06.233
R25-1	RESISTOR	47m OHM 5% 0.6W	MODULOHM I/S	98247/47U-J-MI-A-1	06.233
R26-1	RESISTOR	47m OHM 5% 0.6W	MODULOHM I/S	98247/47U-J-MI-A-1	06.233
R27-1	RESISTOR	47m OHM 5% 0.6W	MODULOHM I/S	98247/47U-J-MI-A-1	06.233
R28-1	RESISTOR	47m OHM 5% 0.6W	MODULOHM I/S	98247/47U-J-MI-A-1	06.233
R29-1	RESISTOR	47m OHM 5% 0.6W	MODULOHM I/S	98247/47U-J-MI-A-1	06.233
R30-1	RESISTOR MF	2k67 OHM 1% 0.25W	PHILIPS	2322 157 12672	02.209
R31-1	RESISTOR MF	226 OHM 1% 0.25W	PHILIPS	2322 157 12261	02.213
RE1-1	RELAY	24VDC 2SH. 2A	OMRON	G5V-2-24 VDC	21.327
RE2-1	RELAY	24VDC 2SH. 2A	OMRON	G5V-2-24 VDC	21.327
TR1-1	TRANSFORMER	3:1:1	SCHAFFNER	IT 244	22.000

AUTO CONTROL (MODULE 2)	N2174	ECI A/S	5-0-26445B / 4-0-26445D	626445
--------------------------------	--------------	----------------	--------------------------------	---------------

POSITION	DESCRIPTION		MANUFACTURER	TYPE	PART NO.
C1-2	CAPACITOR ELECTROLYTIC	470uF -20/+50% 40VDC	ELNA	RJ3-50-471-M-F	14.649
C2-2	CAPACITOR ELECTROLYTIC	10uF 20% 35VDC	ELNA	RJ2-35-V-100-M-T34(T58)	14.512
C3-2	CAPACITOR MKT	100nF 5% 63VDC	PHILIPS	2222 370 79104	11.135
C4-2	CAPACITOR MKT	100nF 5% 63VDC	PHILIPS	2222 370 79104	11.135
C5-2	CAPACITOR ELECTROLYTIC	47uF 20% 25VDC	ELNA	RJ2-25-V-470-M-F1	14.524
C6-2	CAPACITOR ELECTROLYTIC	47uF 20% 25VDC	ELNA	RJ2-25-V-470-M-F1	14.524
C7-2	CAPACITOR MKT	220nF 10% 63VDC	PHILIPS	2222 370 78224	11.095
C8-2	CAPACITOR MKT	470nF 20% 63VDC	ERO	MKT 1826-447/06 6-G	11.188
C9-2	CAPACITOR MKT	15nF 5% 250V	ERO	MKT1818	11.170
C10-2	CAPACITOR MKT	15nF 5% 250V	ERO	MKT1818	11.170
C11-2	CAPACITOR POLYPROPYLENE	1nF 5% 10VDC	ERO	KP 1830-210/01-4-GW	13.398
C12-2	CAPACITOR POLYPROPYLENE	1nF 5% 10VDC	ERO	KP 1830-210/01-4-GW	13.398
C13-2	CAPACITOR MKT	100nF 5% 63VDC	PHILIPS	2222 370 79104	11.135
C14-2	CAPACITOR MKT	1uF 5% 63VDC	ERO	MKT 1826-510/06 4-G	11.190
C15-2	CAPACITOR MKT	1uF 5% 63VDC	ERO	MKT 1826-510/06 4-G	11.190
C16-2	CAPACITOR MKT	1uF 5% 63VDC	ERO	MKT 1826-510/06 4-G	11.190
C17-2	CAPACITOR ELECTROLYTIC	10uF 20% 35VDC	ELNA	RJ2-35-V-100-M-T34(T58)	14.512
C18-2	CAPACITOR ELECTROLYTIC	10uF 20% 35VDC	ELNA	RJ2-35-V-100-M-T34(T58)	14.512
C19-2	CAPACITOR ELECTROLYTIC	10uF 20% 35VDC	ELNA	RJ2-35-V-100-M-T34(T58)	14.512
C20-2	CAPACITOR ELECTROLYTIC	10uF 20% 35VDC	ELNA	RJ2-35-V-100-M-T34(T58)	14.512
D1-2	DIODE RECTIFIER	1N4002 100V/1A	THOMSON	1N4002 (03/04/05/06/07)	25.100
D2-2	DIODE RECTIFIER	1N4002 100V/1A	THOMSON	1N4002 (03/04/05/06/07)	25.100
D3-2	DIODE RECTIFIER	1N4002 100V/1A	THOMSON	1N4002 (03/04/05/06/07)	25.100
D4-2	DIODE RECTIFIER	1N4002 100V/1A	THOMSON	1N4002 (03/04/05/06/07)	25.100
D5-2	DIODE RECTIFIER	1N4002 100V/1A	THOMSON	1N4002 (03/04/05/06/07)	25.100
D6-2	DIODE RECTIFIER	1N4002 100V/1A	THOMSON	1N4002 (03/04/05/06/07)	25.100
D7-2	DIODE HIGH SPEED	1N4448	PHILIPS	1N4448	25.147
D8-2	DIODE RECTIFIER	1N4002 100V/1A	THOMSON	1N4002 (03/04/05/06/07)	25.100
D9-2	DIODE HIGH SPEED	1N4448	PHILIPS	1N4448	25.147
D10-2	DIODE HIGH SPEED	1N4448	PHILIPS	1N4448	25.147
D11-2	DIODE HIGH SPEED	1N4448	PHILIPS	1N4448	25.147

POSITION	DESCRIPTION		MANUFACTOR	TYPE	PART NO.
D12-2	DIODE HIGH SPEED	1N4448	PHILIPS	1N4448	25.147
D13-2	DIODE HIGH SPEED	1N4448	PHILIPS	1N4448	25.147
D14-2	DIODE HIGH SPEED	1N4448	PHILIPS	1N4448	25.147
D15-2	DIODE HIGH SPEED	1N4448	PHILIPS	1N4448	25.147
D16-2	DIODE HIGH SPEED	1N4448	PHILIPS	1N4448	25.147
D17-2	DIODE ZENER	2V7 5% 0.4W BZX79C2V7	PHILIPS	BZX79C2V7	26.506
D18-2	DIODE ZENER	18V 5% 0.4W BZX79C18	PHILIPS	BZX79C18	26.564
D19-2	DIODE RECTIFIER	1N4002 100V/1A	THOMSON	1N4002 (03/04/05/06/07)	25.100
D20-2	DIODE RECTIFIER	1N4002 100V/1A	THOMSON	1N4002 (03/04/05/06/07)	25.100
D21-2	DIODE RECTIFIER	1N4002 100V/1A	THOMSON	1N4002 (03/04/05/06/07)	25.100
D22-2	DIODE HIGH SPEED	1N4448	PHILIPS	1N4448	25.147
D23-2	DIODE HIGH SPEED	1N4448	PHILIPS	1N4448	25.147
D24-2	DIODE HIGH SPEED	1N4448	PHILIPS	1N4448	25.147
D25-2	DIODE HIGH SPEED	1N4448	PHILIPS	1N4448	25.147
D26-2	DIODE HIGH SPEED	1N4448	PHILIPS	1N4448	25.147
D27-2	DIODE HIGH SPEED	1N4448	PHILIPS	1N4448	25.147
D28-2	DIODE HIGH SPEED	1N4448	PHILIPS	1N4448	25.147
D29-2	DIODE ZENER	5.1V 5% 0.4W BZX79C5V1	PHILIPS	BZX79C5V1	26.527
D30-2	DIODE LIGHT EMITTING	Ø3mm RED LOW CURRENT	H.P.	HLMP-K150-OPTION 002	25.662
D31-2	DIODE LIGHT EMITTING	Ø3mm RED LOW CURRENT	H.P.	HLMP-K150-OPTION 002	25.662
D32-2	DIODE LIGHT EMITTING	Ø3mm RED LOW CURRENT	H.P.	HLMP-K150-OPTION 002	25.662
P1-2	PLUG	2x7 POLES	3M	3598-6002 / 7614-6002 JL	78.254
P2-2	PLUG	1/10" SIL SQ.PINS 2 POLES	AMP	0-826629-2 (0-826647-2)	78.322
P3-2	PLUG	1/10" SIL SQ.PINS 2 POLES	AMP	0-826629-2 (0-826647-2)	78.322
P4-2	PLUG	1/10" SIL SQ.PINS 2 POLES	AMP	0-826629-2 (0-826647-2)	78.322
P5-2	PLUG	1/10" SIL SQ.PINS 3 POLES	AMP	0-826629-3 (0-826647-3)	78.323
Q1-2	TRANSISTOR AF	BC547B NPN TO-92	PHILIPS	BC547B	28.067
Q2-2	TRANSISTOR AF	BC547B NPN TO-92	PHILIPS	BC547B	28.067
Q3-2	TRANSISTOR AF	BC547B NPN TO-92	PHILIPS	BC547B	28.067
Q4-2	TRANSISTOR AF	BC547B NPN TO-92	PHILIPS	BC547B	28.067
Q5-2	TRANSISTOR AF	BC547B NPN TO-92	PHILIPS	BC547B	28.067
Q6-2	TRANSISTOR AF	BC547B NPN TO-92	PHILIPS	BC547B	28.067
Q7-2	TRANSISTOR AF	BC338-25 NPN TO-92	PHILIPS	BC338-25	28.058
Q8-2	TRANSISTOR AF	NPN BC639 TO-92	PHILIPS	BC639	28.120
Q9-2	TRANSISTOR AF	NPN BC639 TO-92	PHILIPS	BC639	28.120
R1-2	RESISTOR MF	10k OHM 5% 0.33W	PHILIPS	2322 187 73103	02.496
R2-2	RESISTOR MF	10k OHM 5% 0.33W	PHILIPS	2322 187 73103	02.496
R3-2	RESISTOR MF	3k3 OHM 5% 0.33W	PHILIPS	2322 187 73332	02.484
R4-2	RESISTOR MF	681 OHM 1% 0.25W	PHILIPS	2322 157 16811	02.223
R5-2	RESISTOR MF	1k78 OHM 1% 0.25W	PHILIPS	2322 157 11782	02.205
R6-2	RESISTOR MF	22k OHM 5% 0.33W	PHILIPS	2322 187 73223	02.504
R7-2	RESISTOR MF	1k0 OHM 5% 0.33W	PHILIPS	2322 187 73102	02.472
R8-2	RESISTOR MF	5k11 OHM 1% 0.25W	PHILIPS	2322 157 15112	02.228
R9-2	RESISTOR MF	5k90 OHM 1% 0.25W	PHILIPS	2322 157 15902	02.220
R10-2	RESISTOR MF	2k32 OHM 1% 0.25W	PHILIPS	2322 157 12322	02.225
R11-2	RESISTOR MF	226 OHM 1% 0.25W	PHILIPS	2322 157 12261	02.213
R12-2	RESISTOR MF	100k OHM 5% 0.33W	PHILIPS	2322 187 73104	02.520
R13-2	RESISTOR MF	62k OHM 5% 0.33W	PHILIPS	2322 187 73623	02.515
R14-2	RESISTOR MF	33k OHM 5% 0.33W	PHILIPS	2322 187 73333	02.508
R15-2	RESISTOR MF	10k OHM 5% 0.33W	PHILIPS	2322 187 73103	02.496
R16-2	RESISTOR MF	1k0 OHM 5% 0.33W	PHILIPS	2322 187 73102	02.472
R17-2	RESISTOR MF	10k OHM 5% 0.33W	PHILIPS	2322 187 73103	02.496
R18-2	RESISTOR MF	1k0 OHM 5% 0.33W	PHILIPS	2322 187 73102	02.472
R19-2	RESISTOR MF	10k OHM 5% 0.33W	PHILIPS	2322 187 73103	02.496
R20-2	RESISTOR MF	27k OHM 5% 0.33W	PHILIPS	2322 187 73273	02.506
R21-2	RESISTOR MF	1M OHM 5% 0.33W	PHILIPS	2322 187 73105	02.544
R22-2	RESISTOR MF	10k OHM 5% 0.33W	PHILIPS	2322 187 73103	02.496
R23-2	RESISTOR MF	1k0 OHM 5% 0.33W	PHILIPS	2322 187 73102	02.472
R24-2	RESISTOR MF	6k8 OHM 5% 0.33W	PHILIPS	2322 187 73682	02.492
R25-2	RESISTOR MF	6k8 OHM 5% 0.33W	PHILIPS	2322 187 73682	02.492
R26-2	RESISTOR MF	1k0 OHM 5% 0.33W	PHILIPS	2322 187 73102	02.472
R27-2	RESISTOR MF	4k7 OHM 5% 0.33W	PHILIPS	2322 187 73472	02.488
R28-2	RESISTOR MF	2k7 OHM 5% 0.33W	PHILIPS	2322 187 73272	02.482
R29-2	RESISTOR MF	39 OHM 5% 0.33W	PHILIPS	2322 187 73399	02.438
R30-2	RESISTOR MF	470 OHM 5% 0.33W	PHILIPS	2322 187 73471	02.464
R31-2	RESISTOR MF	470 OHM 5% 0.33W	PHILIPS	2322 187 73471	02.464
R32-2	RESISTOR PMF	1k0 OHM 5% 2W	PHILIPS	2322 194 13102	04.200
R33-2	RESISTOR MF	47k OHM 5% 0.33W	PHILIPS	2322 187 73473	02.512

POSITION	DESCRIPTION		MANUFACTURER	TYPE	PART NO.
R34-2	RESISTOR PMF	1k0 OHM 5% 2W	PHILIPS	2322 194 13102	04.200
R35-2	RESISTOR MF	47k OHM 5% 0.33W	PHILIPS	2322 187 73473	02.512
R36-2	RESISTOR MF	12k OHM 5% 0.33W	PHILIPS	2322 187 73123	02.498
R37-2	RESISTOR MF	12k OHM 5% 0.33W	PHILIPS	2322 187 73123	02.498
R38-2	RESISTOR MF	2k7 OHM 5% 0.33W	PHILIPS	2322 187 73272	02.482
R39-2	PRESET CERMET	5k0 OHM 10% 0.5W	BOURNS	3386P-1-502	07.888
R40-2	RESISTOR MF	33k OHM 5% 0.33W	PHILIPS	2322 187 73333	02.508
R41-2	RESISTOR MF	18k OHM 5% 0.33W	PHILIPS	2322 187 73183	02.502
R42-2	RESISTOR MF	3k3 OHM 5% 0.33W	PHILIPS	2322 187 73332	02.484
R43-2	RESISTOR MF	3k3 OHM 5% 0.33W	PHILIPS	2322 187 73332	02.484
R44-2	RESISTOR MF	10k OHM 5% 0.33W	PHILIPS	2322 187 73103	02.496
R45-2	RESISTOR MF	68k OHM 5% 0.33W	PHILIPS	2322 187 73683	02.516
R46-2	RESISTOR MF	4k7 OHM 5% 0.33W	PHILIPS	2322 187 73472	02.488
R47-2	RESISTOR MF	4k7 OHM 5% 0.33W	PHILIPS	2322 187 73472	02.488
R48-2	RESISTOR MF	4k7 OHM 5% 0.33W	PHILIPS	2322 187 73472	02.488
R49-2	RESISTOR MF	4k7 OHM 5% 0.33W	PHILIPS	2322 187 73472	02.488
R50-2	RESISTOR MF	100k OHM 5% 0.33W	PHILIPS	2322 187 73104	02.520
R51-2	RESISTOR MF	100 OHM 5% 0.33W	PHILIPS	2322 187 73101	02.448
R52-2	RESISTOR MF	1M OHM 5% 0.33W	PHILIPS	2322 187 73105	02.544
R53-2	RESISTOR MF	30k OHM 5% 0.33W	PHILIPS	2322 187 73303	02.507
R54-2	RESISTOR MF	30k OHM 5% 0.33W	PHILIPS	2322 187 73303	02.507
R55-2	RESISTOR MF	1k0 OHM 5% 0.33W	PHILIPS	2322 187 73102	02.472
R56-2	RESISTOR MF	1k0 OHM 5% 0.33W	PHILIPS	2322 187 73102	02.472
R57-2	RESISTOR MF	10 OHM 5% 0.33W	PHILIPS	2322 187 73109	02.424
R58-2	RESISTOR MF	1k5 OHM 5% 0.33W	PHILIPS	2322 187 73152	02.476
R59-2	RESISTOR MF	1k5 OHM 5% 0.33W	PHILIPS	2322 187 73152	02.476
R60-2	PRESET CERMET	2k0 OHM 5% 0.5W	BOURNS	3386P-1-202-11	07.887
R61-2	RESISTOR MF	82 OHM 5% 0.33W	PHILIPS	2322 187 73829	02.446
R62-2	RESISTOR MF	1k5 OHM 5% 0.33W	PHILIPS	2322 187 73152	02.476
R63-2	PRESET CERMET	5k0 OHM 10% 0.5W	BOURNS	3386P-1-502	07.888
R64-2	RESISTOR MF	2k2 OHM 5% 0.33W	PHILIPS	2322 187 73222	02.480
R65-2	RESISTOR MF	33k OHM 5% 0.33W	PHILIPS	2322 187 73333	02.508
R66-2	RESISTOR MF	68k OHM 5% 0.33W	PHILIPS	2322 187 73683	02.516
R67-2	RESISTOR MF	18k OHM 5% 0.33W	PHILIPS	2322 187 73183	02.502
R68-2	RESISTOR MF	68k OHM 5% 0.33W	PHILIPS	2322 187 73683	02.516
R69-2	RESISTOR MF	68k OHM 5% 0.33W	PHILIPS	2322 187 73683	02.516
R70-2	RESISTOR MF	270k OHM 5% 0.33W	PHILIPS	2322 187 73274	02.530
R71-2	RESISTOR MF	10k OHM 5% 0.33W	PHILIPS	2322 187 73103	02.496
R72-2	RESISTOR MF	1M2 OHM 5% 0.33W	PHILIPS	2322 187 73125	02.546
R73-2	RESISTOR MF	10k OHM 5% 0.33W	PHILIPS	2322 187 73103	02.496
R74-2	RESISTOR MF	1M2 OHM 5% 0.33W	PHILIPS	2322 187 73125	02.546
R75-2	RESISTOR MF	10k OHM 5% 0.33W	PHILIPS	2322 187 73103	02.496
R76-2	RESISTOR MF	1M2 OHM 5% 0.33W	PHILIPS	2322 187 73125	02.546
R77-2	RESISTOR MF	10k OHM 5% 0.33W	PHILIPS	2322 187 73103	02.496
R78-2	RESISTOR MF	10k OHM 5% 0.33W	PHILIPS	2322 187 73103	02.496
R79-2	RESISTOR MF	2k7 OHM 5% 0.33W	PHILIPS	2322 187 73272	02.482
R80-2	RESISTOR MF	2k2 OHM 5% 0.33W	PHILIPS	2322 187 73222	02.480
R81-2	RESISTOR MF	2k2 OHM 5% 0.33W	PHILIPS	2322 187 73222	02.480
R82-2	RESISTOR MF	2k2 OHM 5% 0.33W	PHILIPS	2322 187 73222	02.480
TR1-2	TRANSFORMER	3:1:1	SCHAFFNER	IT 244	22.000
U1-2	POS. VOLTAGE REG. 15V/1A	MCT7815-MC7815-LM340T-15	MOTOROLA	MCT7815CT (MCT7815BT)	31.090
U2-2	DUAL OP AMP	LM358N	TEXAS	LM358P	31.100
U3-2	VOLTAGE REG. ADJUSTABLE	Io=0.1A LM317L	TEXAS	TL317CLP	31.145
U4-2	DUAL OP AMP	LM358N	TEXAS	LM358P	31.100
U5-2	DUAL OP AMP	LM358N	TEXAS	LM358P	31.100
U6-2	DUAL OP AMP	LM358N	TEXAS	LM358P	31.100
U7-2	QUAD 2-INP.NAND SCHM.TRI	MC14093BCP	MOTOROLA*	MC14093BCP	33.300

TECHNICAL MANUAL FOR AERIAL COUPLER AT2112
PART NO. 802112

CONTENTS

1	GENERAL INFORMATION	
1.1	INTRODUCTION	1-1
1.2	PRINCIPLE OF OPERATION AND BLOCK DIAGRAM	1-1
1.3	TECHNICAL DATA	1-1
2	INSTALLATION	
2.1	DIMENSIONS AND DRILLING PLAN	2-1
2.2	ELECTRICAL CONNECTION AND ASSEMBLING	2-2
2.3	AERIAL AND GROUND	2-3
3	SERVICE	
3.1	MAINTENANCE	3-1
3.2	ALIGNMENT INSTRUCTIONS	3-1
3.3	PROPOSAL FOR NECESSARY MEASURING INSTRUMENTS	3-1
3.4	TROUBLE SHOOTING	3-1
3.5	FUNCTION CHECK	3-1
4	MECHANICAL DESCRIPTION	
4.1	MECHANICAL ASSEMBLING / DISASSEMBLING AND UNITS LOCATION	4-1
5	CIRCUIT DESCRIPTION AND SCHEMATIC DIAGRAMS	
5.1	AERIAL CURRENT DETECTOR (MODULE 1) PART NO. 626641	5-1
5.2	MAIN SCHEMATIC DIAGRAM AT2112	5-5
6	PARTS LISTS	

CONTENTS

1	GENERAL INFORMATION	1-1
1.1	INTRODUCTION	1-1
1.2	PRINCIPLE OF OPERATION AND BLOCK DIAGRAM	1-1
1.3	TECHNICAL DATA	1-1

1 GENERAL INFORMATION

1.1 INTRODUCTION

This section gives you all necessary information to make service of this unit down to component level.

1.2 PRINCIPLE OF OPERATION AND BLOCK DIAGRAM

The aerial coupler is controlled from the TX processor.

The aerial coupler tunes the aerial impedance to fit the 50 ohm impedance of the PA unit.

The impedance is measured at the output of the PA unit. It is always possible to tune an SWR less than 2, typically SWR = 1.4.

The aerial coupler has three main parts, a 4:1 impedance transformer at the input at the coupler, then a series coil, which can be tuned in steps as well as continuously, and at last a parallel capacitor, which can be tuned in steps. The value of the coil and the capacitor is controlled in the TX processor.

The aerial coupler has an impedance matching transformer (TR1-1) for the receiver for frequencies lower than 4MHz.

At the output there is a current transformer (TR2-1) and a detector. The output voltage is fed to the aerial current meter at RE2100.

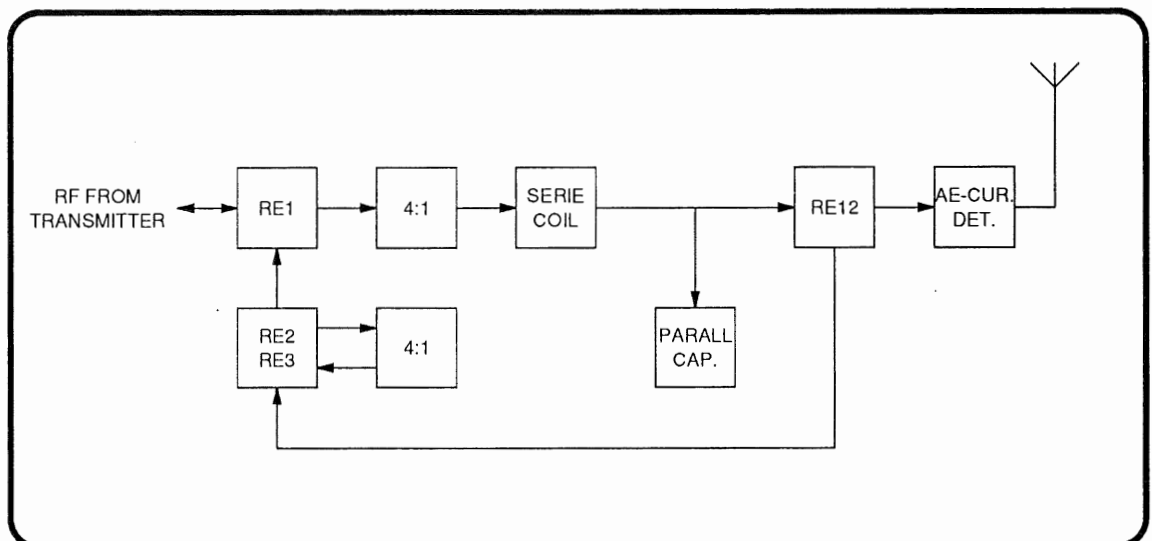

28486

1.3 TECHNICAL DATA

Max handling Power: 1200W PEP

Aerial: Wire or whip aerial, 9 - 16 metres length

Temperature Range: -25°C to +70°C

Tuning Time: Typical less than 2 sec.
Learn mode up to approx. 3 minutes

CONTENTS

2	INSTALLATION	2-1
2.1	DIMENSIONS AND DRILLING PLAN	2-1
2.2	ELECTRICAL CONNECTION AND ASSEMBLING	2-2
2.3	AERIAL AND GROUND	2-3

2 INSTALLATION

2.1 DIMENSIONS AND DRILLING PLAN

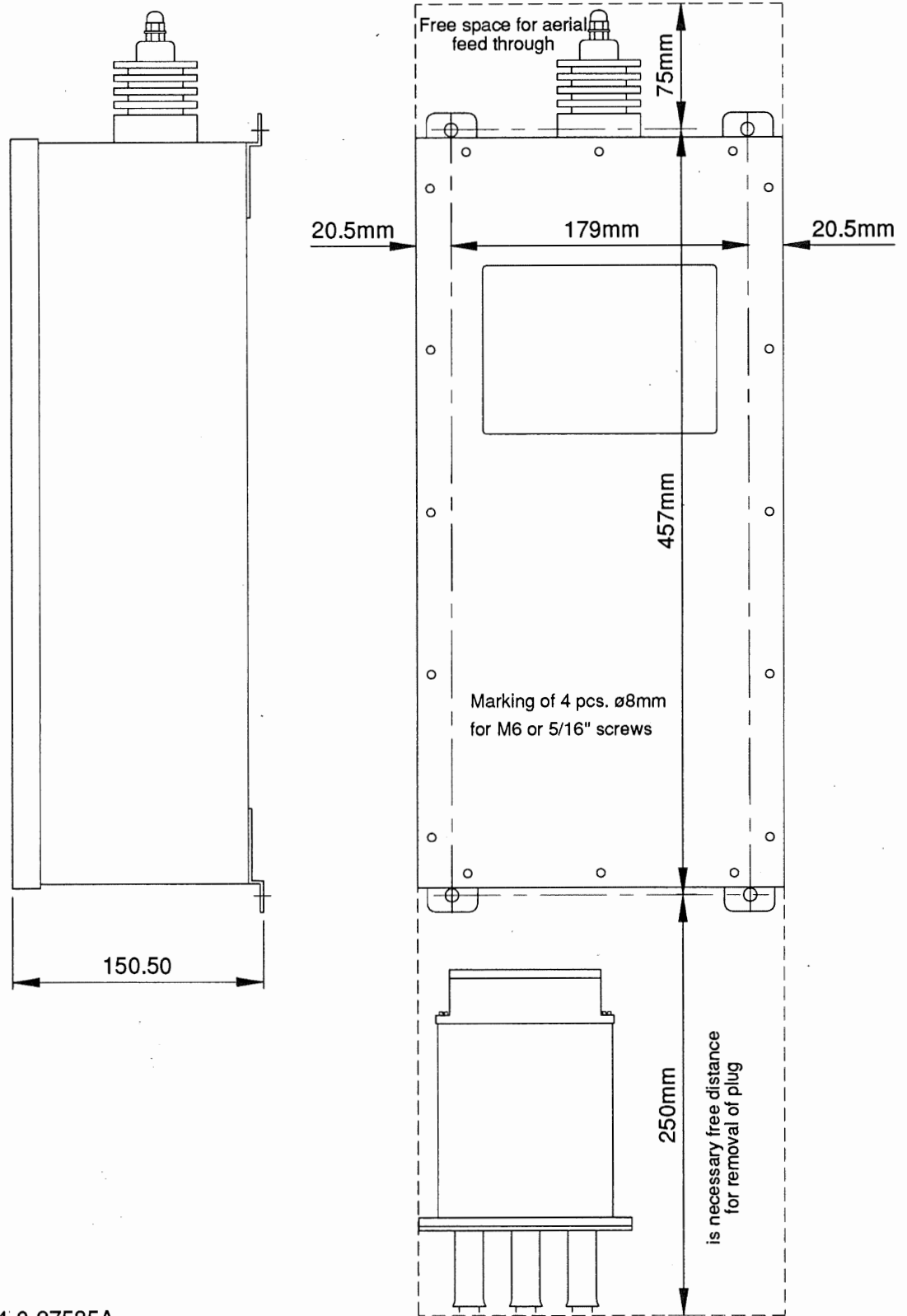

4-0-27535A

2.2 ELECTRICAL CONNECTION AND ASSEMBLING

CABLE MOUNTING DETAILS FOR AT2112

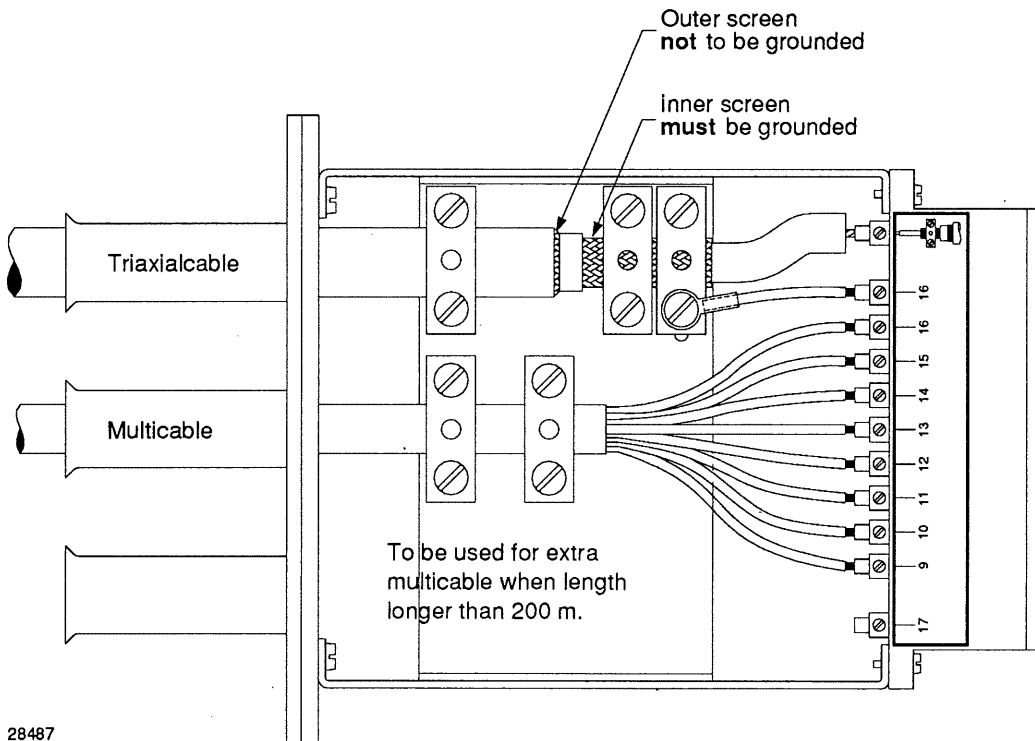

28487

MULTICABLE:

Lead 9-16 incl. to be connected on this side. Lead 1-8 incl. to be connected on rear side. The numbers in plug for AT2112 correspond with the numbers on the terminal block at the connection board in question (control 1, control 2, etc.).

MULTICABLE: Max. diameter ° 14.5 mm.

length	type
1 - 100 m	16 x 0.5°
100 - 200 m	18 x 0.5°

Terminal 15 have 3 leads in parralel.

WIRE STRIPPING FOR MULTICABLE.

WIRESTRIPPING FOR TRIAXIAL CABLE H1213.

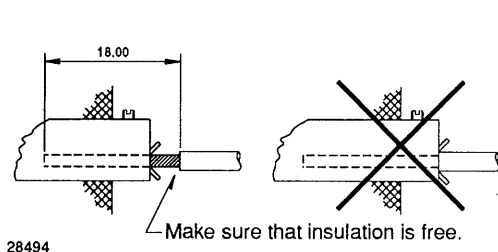

28494

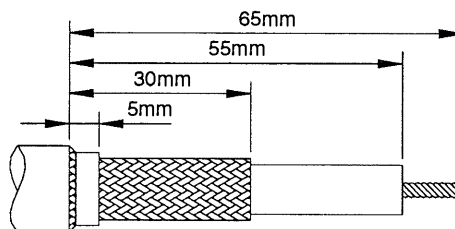

28495

2.3 AERIAL AND GROUND

AERIAL

Most important for good communication is the aerial. The best efficiency of the aerial will be with the aerial coupler AT2112 mounted outdoors, close to the footpoint of the aerial and the aerial placed as high and free as possible. The aerial coupler AT2112 has to be grounded carefully.

AERIAL LENGTH

Max. length 16 meters, min. length 9 meters. The aerial length is measured from the insulator on AT2112 to the top of the aerial.

If the transmitter has to work mainly on frequencies below 4 MHz a total aerial length of 15 meters is recommended.

If the transmitter has to work mainly on frequencies higher than 4 MHz an 8.5 meters whip aerial is recommended.

GROUND

The grounding points on AT2112 are the four mounting feet. It is most important that these are in good contact with the ground, eg. the wheel house.

AT2112 has to be grounded at the footpoint of the aerial.

If a metal wheel house, weld up a pillar for AT2112 and bolt it to the pillar. This way you get the best ground for your antenna system.

If a wooden or fibre glass boat, connect all accessible metal parts together and connect them to the aerial coupler with a copper strip (100 x 0.5 mm), making the copper strip as short as possible. You can also make an artificial ground under the aerial coupler as shown in example 5.

Example 1. AT2112 mounted on top of a wheel house with a whip aerial.

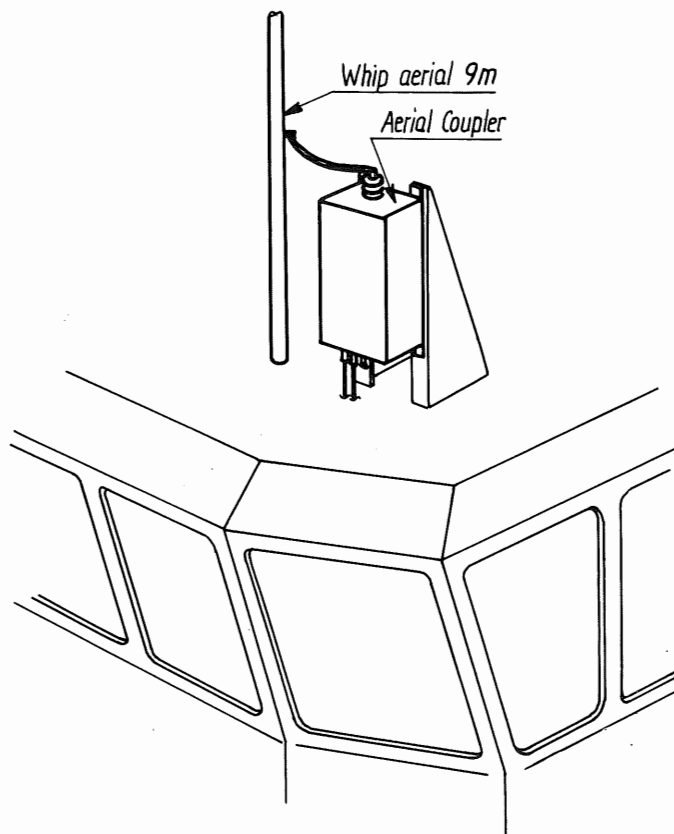

AT2112 has to be grounded through the two lower mounting holes.

Example 2. AT2112 mounted on top of a wheel house with wire aerial.

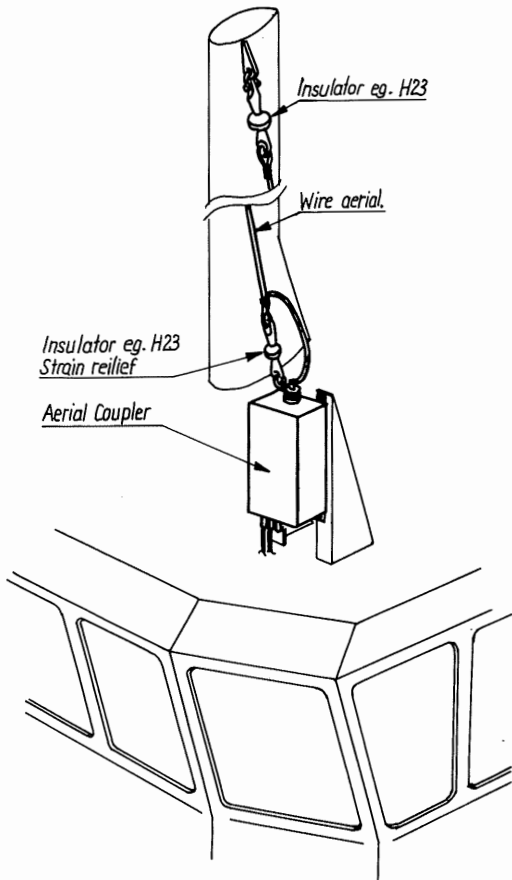

4-0-25235

Example 3. AT2112 mounted on top of a mast.

AT 2112 has to be grounded to the mast if a metal mast.

If the mast is higher than 8 meters, then the coax cable works as ground and acceptable performance will be obtained.

If the mast is less than 8 meters, then a copper strip (100 x 0.5 mm) has to be connected from AT2112 to ground.

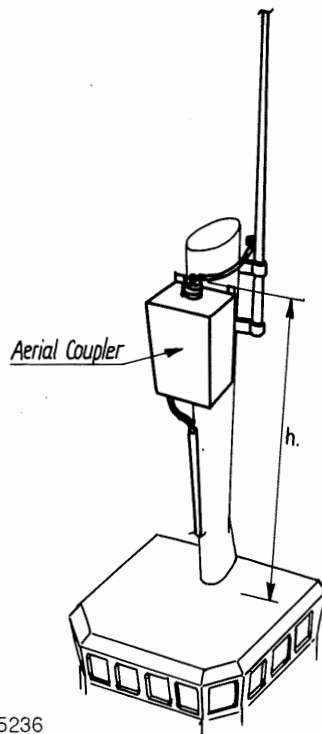

4-0-25236

Example 4. AT2112 mounted on a sailing ship.

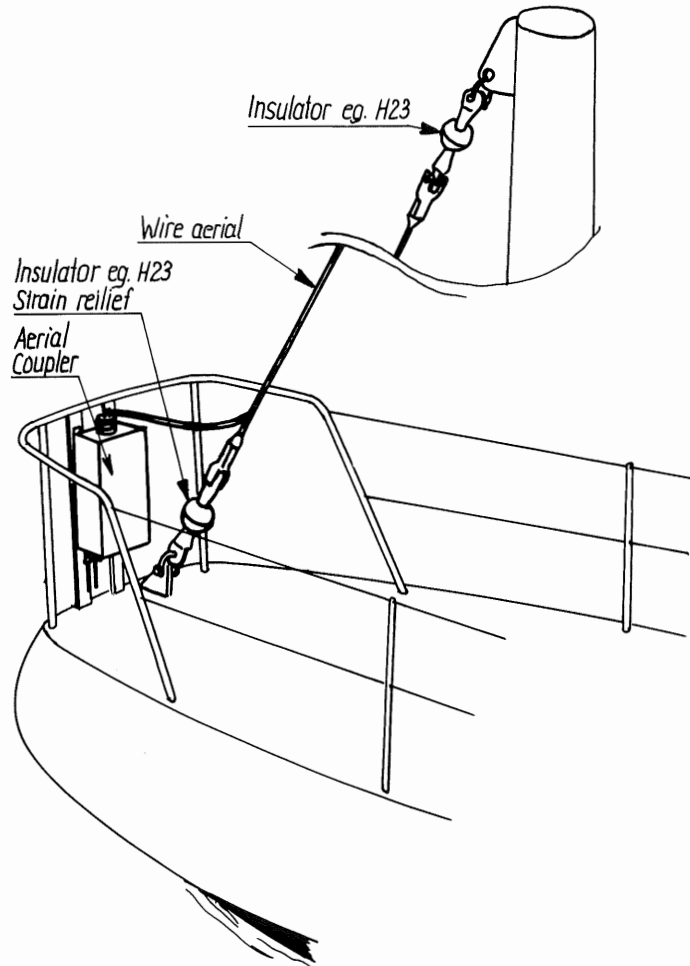

4-0-25237

AT2112 has to be grounded to the metal handrail or other metal parts.

Example 5. AT2112 mounted on top of building.

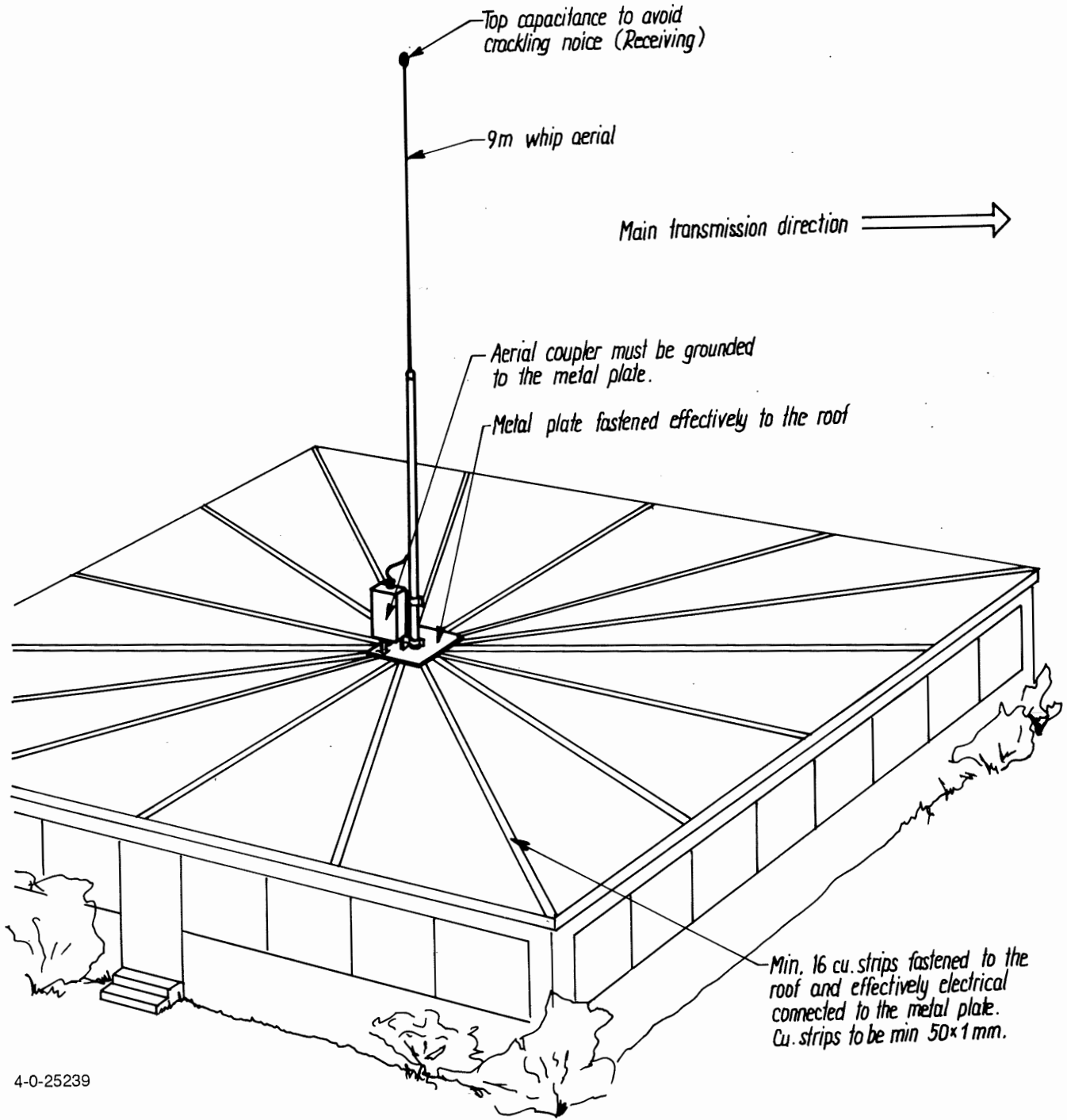

4-0-25239

CONTENTS

3	SERVICE	3-1
3.1	MAINTENANCE	3-1
3.2	ALIGNMENT INSTRUCTIONS	3-1
3.3	PROPOSAL FOR NECESSARY MEASURING INSTRUMENTS	3-1
3.4	TROUBLE SHOOTING	3-1
3.5	FUNCTION CHECK	3-1

3 SERVICE

3.1 MAINTENANCE

PREVENTIVE MAINTENANCE

If the HF SSB system has been installed properly the maintenance can, dependent on the environments and working hours, be reduced to a performance check at intervals, not exceeding 12 months. A complete performance check is enclosed in this manual, chapter 3.5. PERFORMANCE CHECK.

Inspection of the antenna, cables, and plugs for mechanical defects, salt deposits, corrosion, and any foreign bodies shall be done at regular intervals not exceeding 12 months.

Along with each HF SSB system test sheets are delivered in which all the measurements made in the test department of the factory, are listed. If the control mesurings made in the service workshop should not show the same values as those listed in the test sheet, the set must be adjusted as specified in the parts concerning the units in question.

3.2 ALIGNMENT INSTRUCTIONS

INTRODUCTION

The measuring values indicated in chapter 5. CIRCUIT DESCRIPTION AND SCHEMATIC DIAGRAMS are typical values and as indicated it will be necessary to use instruments in absolute conformity with the below list:

3.3 PROPOSAL FOR NECESSARY MEASURING INSTRUMENTS

Tone Generator type PM5107	PHILIPS
Electronic Multimeter type PM2505	PHILIPS
RF Directional Wattmeter model 43	BIRD
Oscilloscope type PM321	PHILIPS
Dummy load 50 ohm/600W	
Power supply 21-32V,	50A (600W transmitter)
	100A (1200W transmitter)

3.4 TROUBLE SHOOTING

Trouble shouting in a high power circuit where high voltage are preset, can normally be done by looking into the circuit, and spot the defective component. Only if it is one of the relays or semiconductors that are defective, you have to make measurements.

3.4.1 CHECKS OF RELAYS

To check the relays, AT2112 must be connected to the transmitter.

Select serve programme SP-30-0 to SP-30-9 and SP-31-0 to SP-31-4, please see part I paragraph 3.8.2. The service programme will enable you to activate each relay in the aerial coupler, so you can see if it works.

3.4.2 CHECK OF THE TUNE MOTOR.

Select service programme SP-32-1 see part I paragraph 3.8.2, and check that the tune motor are running with low speed.

Select SP-32_2, and check that the tune motor are running full speed.

Select SP-32-0, and check that the tune motor stops.

3.4.3 CHECK OF THE 180° PULSE CIRCUIT.

Select SP-32-1 and connect a oscilloscope to P3 on the aerial detector module (1) (chassis as reference), and check that it goes high once every turn of the tune motor.

3.5 FUNCTION CHECK

To perform a function check, it is necessary to have a complete station, and it must be connected to a suitable aerial. Then you must perform the function check described in part I paragraph 3.7.

CONTENTS

4	MECHANICAL DESCRIPTION	4-1
4.1	MECHANICAL ASSEMBLING / DISASSEMBLING AND UNITS LOCATION	4-1

4.1 MECHANICAL ASSEMBLING / DISASSEMBLING AND UNITS LOCATION

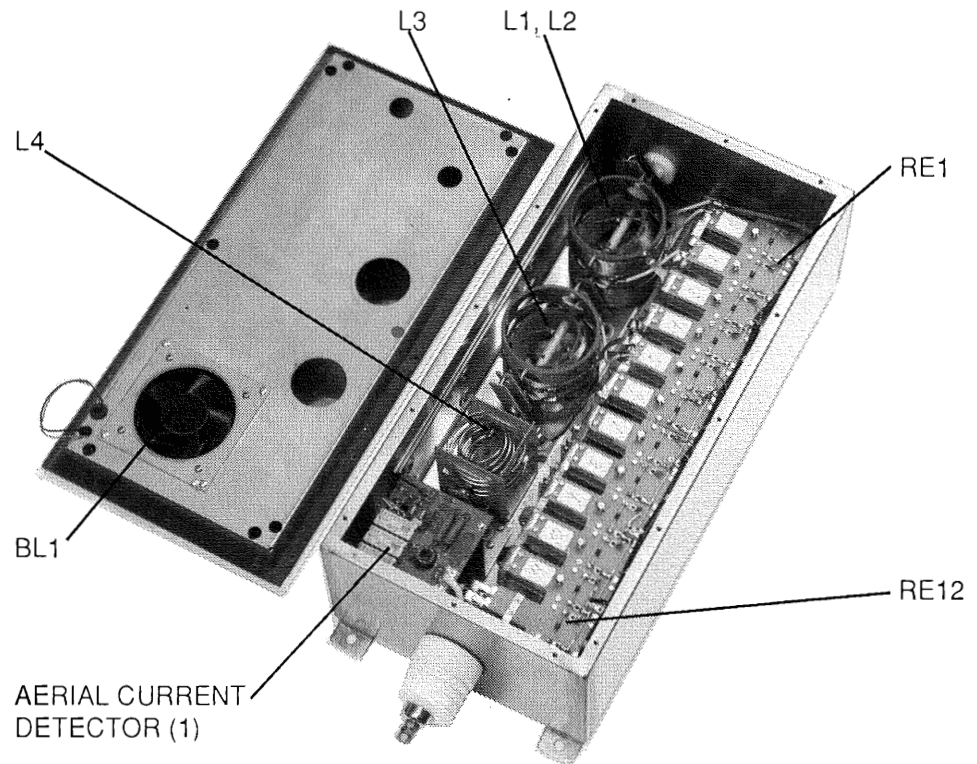

501134



50112

CONTENTS

5	CIRCUIT DESCRIPTION AND SCHEMATIC DIAGRAMS	
5.1	AERIAL CURRENT DETECTOR (MODULE 1) PART NO. 626641	5-1
5.2	MAIN SCHEMATIC DIAGRAM AT2112	5-1

5 CIRCUIT DESCRIPTION AND SCHEMATIC DIAGRAMS

5.1 AERIAL CURRENT DETECTOR (1)

This module contains three main circuits:

1. Aerial current detector
2. 180° pulse circuit.
3. RF switching circuit.

5.1.1 AERIAL CURRENT DETECTOR

The current to the aerial is fed through TR2. On the secondary side of TR2 there will be a voltage proportional to the aerial current. This voltage is rectified by D2 and C3, and fed to the TX-processor.

5.1.2 180° PULSE CIRCUIT

When the motor is running, current flows through the light emitting diode of OC1, and the detector transistor is turned on, and thus Q1 will be on, giving a low level on P3.

For every turn the light from the light emitting diode is cut off mechanically, causing the detector transistor of OC1 to turn off, and thus Q1 will be off, giving a high level at P3. This pulse is used to determine when to change the relay settings.

5.1.3 RF SWITCHING CIRCUIT.

Depending on the mode (refer to 5.2) in which the aerial coupler is working the relays will be activated in accordance with the table below.

MODE		RE1	RE2	RE3
RECEIVE MODE	simplex F>4 Mhz	off	on	off
	simplex F<4 Mhz	off	on	on
	simplex, TX tuned	on	off	off
TRANSMIT MODE	straight through	off	off	off
	tuned	on	off	off
OPEN AERIAL		on	off	on
GROUNDING AERIAL		off	off	off

COMPONENT LOCATION AERIAL CURRENT DETECTOR MODULE 1

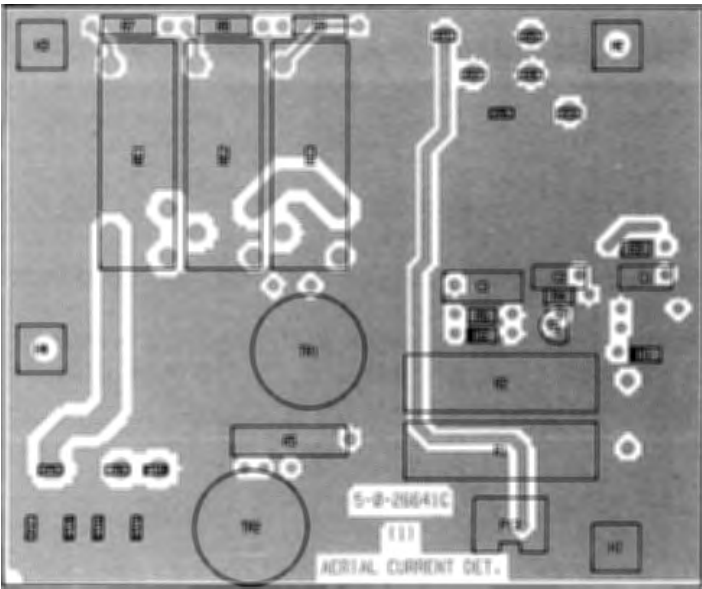

View from component side with upper side tracks.

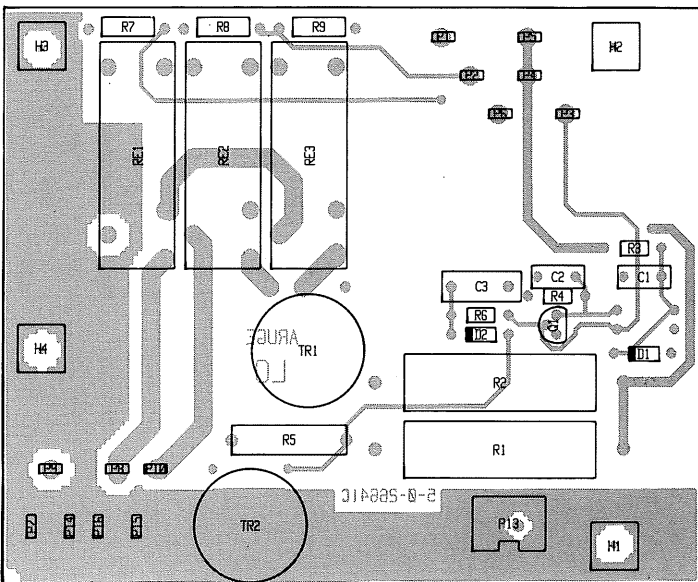

View from component side with lower side tracks.

AERIAL CURRENT DETECTOR MODULE 1

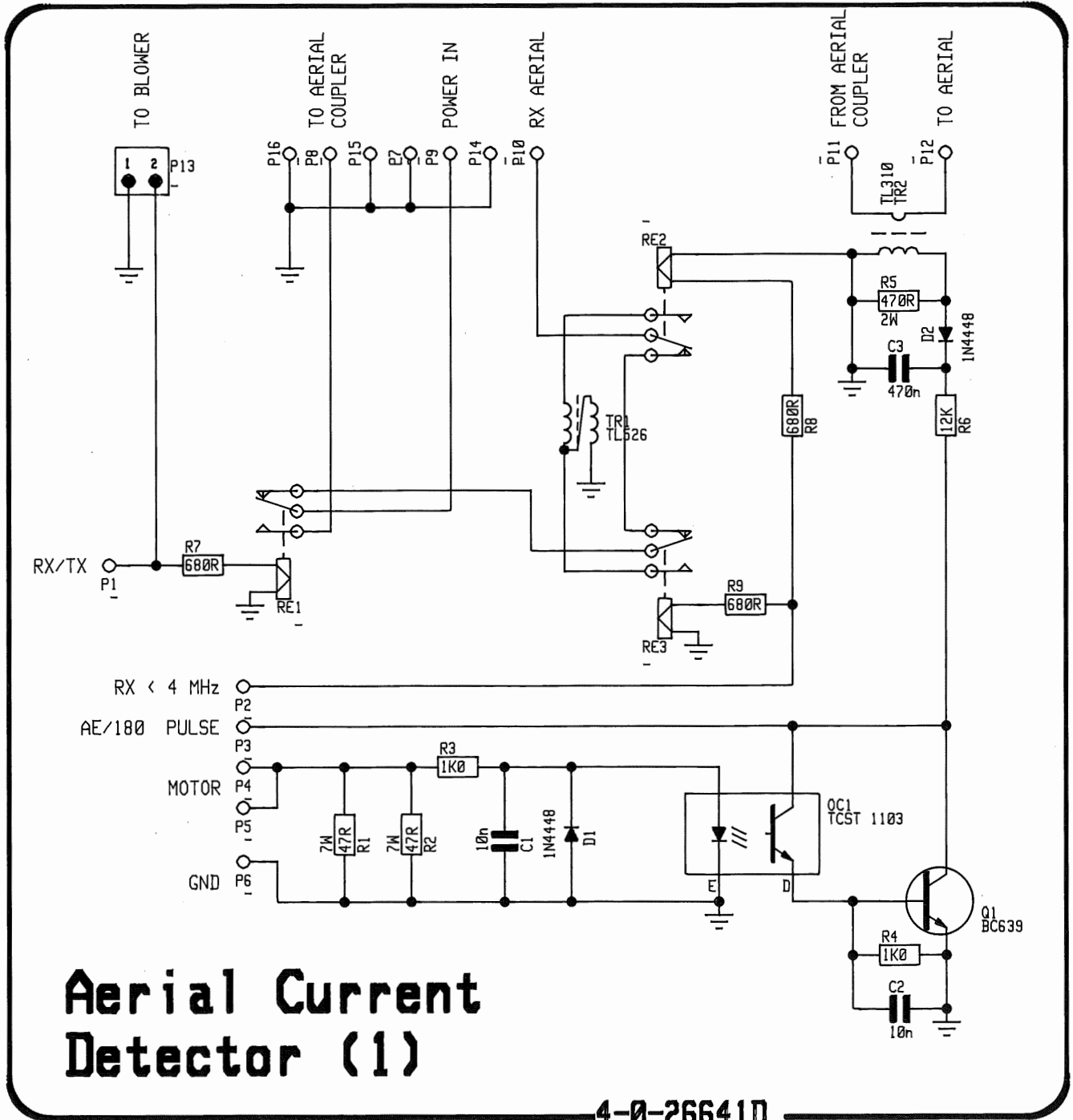

4-0-26641D

Aerial Current Detector (1)

4-0-26641D

5.2 MAIN SCHEMATIC DIAGRAM AT2112

The aerial coupler AT2112 is controlled from the TX - processor in the transmitter. The aerial coupler can be in two different modes:

1. Receive mode.
2. Transmit mode.

5.2.1 RECEIVE MODE.

In this mode there are two different settings, one is simplex the other is semiduplex.

5.2.1.1 SEMIDUPLEX MODE AND THE FREQUENCY HIGHER THAN 4 MHZ.

The signal is feed from the aerial trough RE12-RE2-RE3 and RE1 to the receiver via the connection board in the transmitter.

5.2.1.2 SIMPLEX MODE AND THE FREQ. LOWER THAN OR EQUAL TO 4 MHZ.

In this mode RE2 and RE3 are activated. The signal from the aerial is feed trough RE12 -RE2 to TR1 (module 1) then further through RE3 - RE1 to the receiver via the connection board in the transmitter.

TR1 is transforming the high aerial impedance down to the lower impedance of the receiver. This gives the receiver a improved sensitivity on short aerials.

5.2.1.3 SIMPLEX MODE. RECEIVE FREQUENCY EQUAL TO TRANSMIT FREQ.

In this mode, is the receiver using the tuning. which has been done by the transmitter. This will only take place after the transmitter has performed a tuning. This gives a perfect match of the aerial impedance to the receiver input impedance, this will improve the receiver sensitivity by approx. 10 dB.

5.2.2 TRANSMIT MODE

Here there are two different modes:

1. Straight trough
2. Tuning.

5.2.2.1 STRAIGHT TROUGH MODE.

This mode is always selected as first choice by the TX-processor in the transmitter. In this mode the signal from the transmitter is feed trough RE1-RE3-RE4-RE2 to the aerial. This mode is used when the aerial impedance is 50 ohms.

5.2.2.2 TUNING MODE.

This mode is selected if the aerial impedance is different from 50 ohm. The tuning sequence is controlled by the TX-processor, please refer also to PART I paragraph 3.5.3 tuning the AT2112. RE1 and RE12 will always be activated in tune mode. The signal from the transmitter will be feed to TR1 and the impedance will be transformed to 12.5 ohm, this is the impedance for which the tuning circuit will tune.

MAIN SCHEMATIC DIAGRAM AT2112

4-0-26641D / 802112E

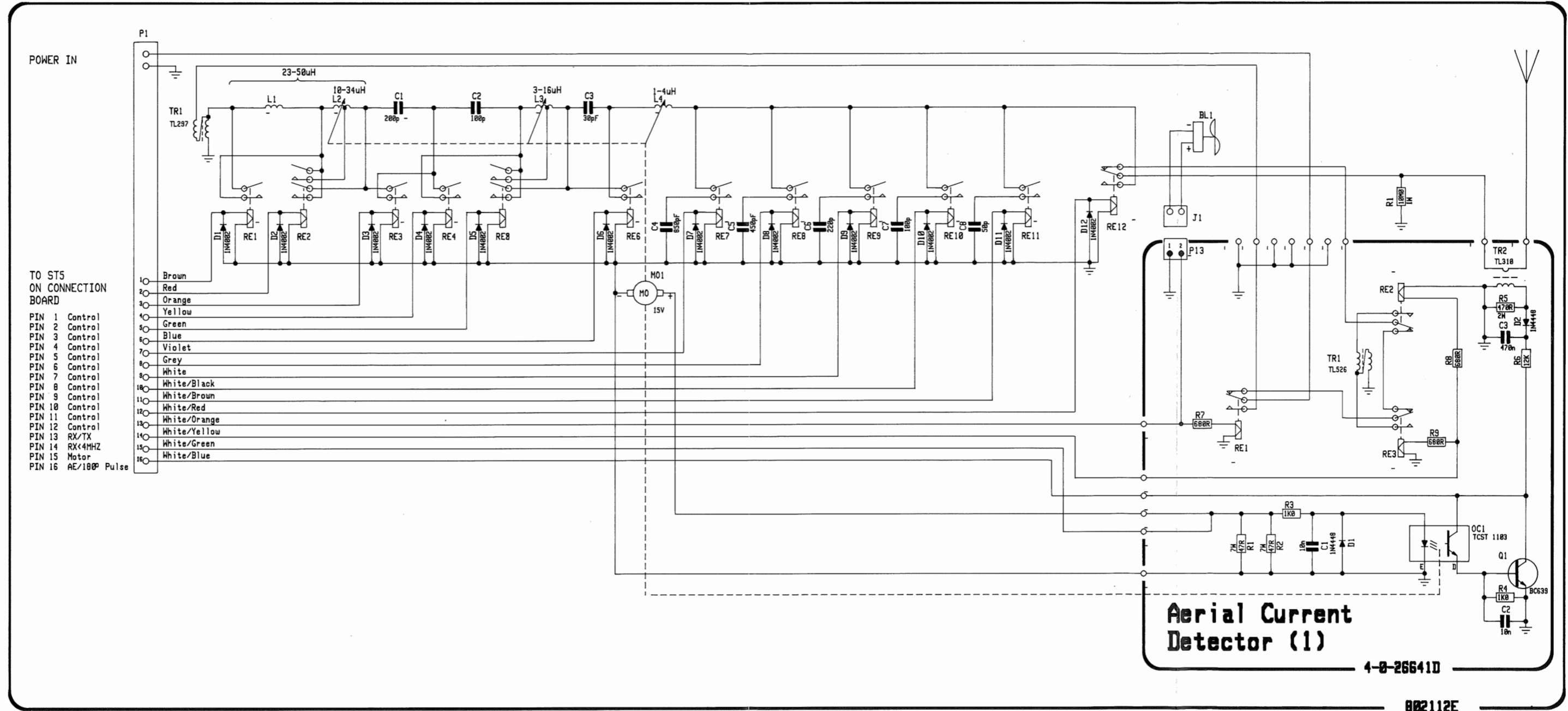

CONTENTS

6 PARTS LISTS

6-1

6 PARTS LISTS

BASE UNIT AT2112			ECI A/S	702112	
POSITION	DESCRIPTION		MANUFACTOR	TYPE	PART NO.
VARIOUS	CABLE AT2112		ECI A/S	0-0-27413	527413
VARIOUS			PADRE	Nr:30 Ø4x125mm B=4mm	66.526
-1	AERIAL CURRENT DET.MODULE	AT2112	ECI A/S	5-0-26641C / 4-0-26641D	626641
BL1	FAN 24VDC	80x80mm	ELINA FAN	HDF 8025L-24MB	60.050
C1	CAPACITOR CERAMIC	200pF 20% N470 5kVDC	LCC	WA04T00201M	18.065
C2	CAPACITOR CERAMIC	100pF 20% N33 5kVDC	LCC	WA04H00101M	18.050
C3	CAPACITOR CERAMIC	30pF 20% N33 5kVDC	LCC	WA03H00300M	18.015
C4	STAK CAPACITOR 850pF	AT150x	ECI A/S	STAKKOND.1 850pF	707779
C5	STAK CAPACITOR 450pF	AT150x	ECI A/S	STAKKOND. 2 450pF	707780
C6	CAPACITOR CERAMIC	220pF 20% N470 5kVDC	LCC	WA04T00221M	18.070
C7	CAPACITOR CERAMIC	100pF 20% N33 5kVDC	LCC	WA04H00101M	18.050
C8	CAPACITOR CERAMIC	50pF 20% N33 5kVDC	LCC	WA03H00500M	18.020
J1	RECEPTACLE (FEMALE)	2 POLE	AMP	0-826371-2	78.122
L1+L2	VARIOMETER I AT1500		ECI A/S	VARIOMETER 1	707756
L3	VARIOMETER II AT1500		ECI A/S	VARIOMETER 2	707757
L4	VARIOMETER III AT1500		ECI A/S	VARIOMETER 3	707758
MO1	MOTOR W. GEARBOX	C1065	MAXON	SP SPEC.: C1065	60.010
P1	PLUG		ECI A/S	KEJSERSTIK	707773
R1	RESISTOR HIGH VOLTAGE	10M OHM 10% 10kVDC	PHILIPS	2322 244 13106	06.050
RE1	RELAY	ORF1501	ECI A/S	ORF1501 SLUTTERELÆ	705051
RE2	RELAY ORF1503		ECI A/S	ORF1503 SLUTTER.m/HVILEK.	705068
RE3	RELAY	ORF1501	ECI A/S	ORF1501 SLUTTERELÆ	705051
RE4	RELAY	ORF1501	ECI A/S	ORF1501 SLUTTERELÆ	705051
RE5	RELAY ORF1503		ECI A/S	ORF1503 SLUTTER.m/HVILEK.	705068
RE6	RELAY	ORF1501	ECI A/S	ORF1501 SLUTTERELÆ	705051
RE7	RELAY	ORF1501	ECI A/S	ORF1501 SLUTTERELÆ	705051
RE8	RELAY	ORF1501	ECI A/S	ORF1501 SLUTTERELÆ	705051
RE9	RELAY	ORF1501	ECI A/S	ORF1501 SLUTTERELÆ	705051
RE10	RELAY	ORF1501	ECI A/S	ORF1501 SLUTTERELÆ	705051
RE11	RELAY	ORF1501	ECI A/S	ORF1501 SLUTTERELÆ	705051
RE12	RELAY	ORF1502	ECI A/S	ORF1502 SKIFTERELÆ	705061
TR1	TRANSFORMER	TL297	ECI A/S	6-0-22611	400297

AERIAL CURRENT DET.MODULE			AT2112	ECI A/S	5-0-26641C / 4-0-26641D	626641
POSITION	DESCRIPTION		MANUFACTOR	TYPE	PART NO.	
C1-1	CAPACITOR CERAMIC	10nF -20/+80% CL2 50VDC	KCK	RT-HE70 SK YF 103 Z	15.170	
C2-1	CAPACITOR CERAMIC	10nF -20/+80% CL2 50VDC	KCK	RT-HE70 SK YF 103 Z	15.170	
C3-1	CAPACITOR MKT	470nF 10% 63V	ERO*	MKT 1818-447/065	11.185	
D1-1	DIODE HIGH SPEED	1N4448	PHILIPS	1N4448	25.147	
D2-1	DIODE HIGH SPEED	1N4448	PHILIPS	1N4448	25.147	
OC1-1	PHOTO INTERRUPTER		TELEFUNKEN	TCST 1103	32.521	
P13-1	PLUG	2 POLES	AMP	0-826375-2	78.102	
Q1-1	TRANSISTOR AF	NPN BC639 TO-92	PHILIPS	BC639	28.120	
R1-1	RESISTOR	47 OHM 5% 7W	PHILIPS	2322 329 07479	05.866	
R2-1	RESISTOR	47 OHM 5% 7W	PHILIPS	2322 329 07479	05.866	
R3-1	RESISTOR MF	1k0 OHM 5% 0.33W	PHILIPS	2322 187 73102	02.472	
R4-1	RESISTOR MF	1k0 OHM 5% 0.33W	PHILIPS	2322 187 73102	02.472	
R5-1	RESISTOR PMF	470 OHM 5% 2W	PHILIPS	2322 194 13471	04.191	
R6-1	RESISTOR MF	12k OHM 5% 0.33W	PHILIPS	2322 187 73123	02.498	
R7-1	RESISTOR MF	680 OHM 5% 0.4W	PHILIPS	2322 181 53681	01.195	
R8-1	RESISTOR MF	680 OHM 5% 0.4W	PHILIPS	2322 181 53681	01.195	
R9-1	RESISTOR MF	680 OHM 5% 0.4W	PHILIPS	2322 181 53681	01.195	
RE1-1	RELAY	12VDC 1SH. 8A.	SCHRACK	RY S 12 012	21.031	
RE2-1	RELAY	12VDC 1SH. 8A.	SCHRACK	RY S 12 012	21.031	
RE3-1	RELAY	12VDC 1SH. 8A.	SCHRACK	RY S 12 012	21.031	
TR1-1	TRANSFORMER	TL526	ECI A/S	6-0-25867B	400526	
TR2-1	TRANSFORMER	TL310	BB	6-0-23162E	400310	